

KickStart
KS008A6
4 Line
Big Digit
Intelligent LCD

Product Specification

GPEG International Ltd Issue 1.3.0

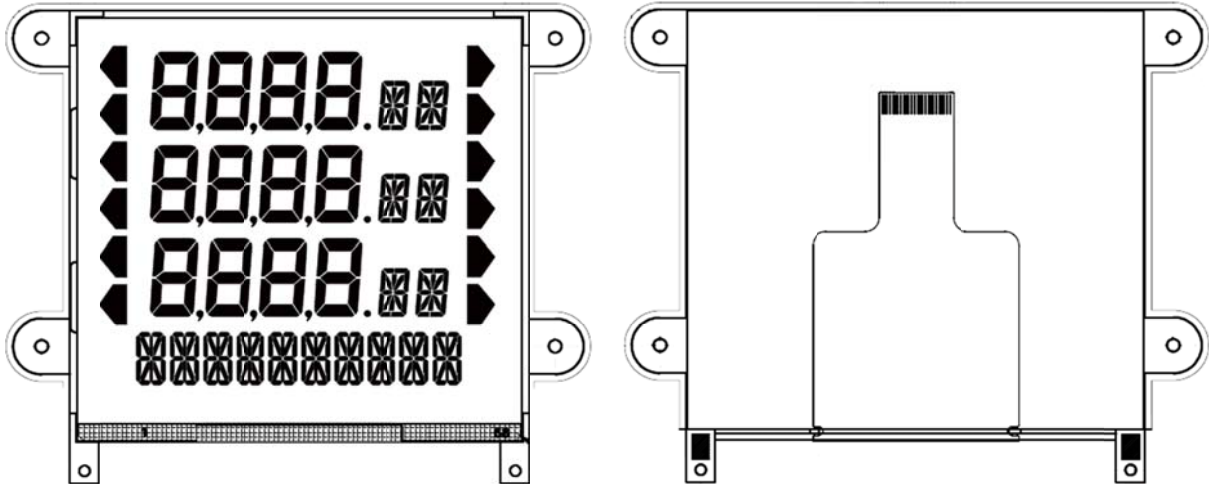

KickStart™ KS008A6



The KS008A6 is a 364-segment monochrome demonstration/development LCD driven by the unique KickStart™ KS480 LCD controller driver IC. Designed for use with the KickStart™ Development Kit, this LCD allows for demonstration of the KickStart™ platform's design capabilities or can be used to perform rapid prototyping for product development.

For full information on KickStart™ and its LCD design tools visit:
http://www.gpegint.com/products/custom_lcd/kickstart/specification



CONTENTS

Contents

KickStart™ KS008A6	2
1. FEATURES	4
2. MECHANICAL SPECIFICATIONS	4
3. ELECTRICAL SPECIFICATION	4
3.1. Absolute Maximum Ratings ($V_{SS} = 0V$)	4
3.2. Electrical Characteristics ($V_{SS} = 0V$)	5
4. ELECTRO-OPTICAL CHARACTERISTICS OF LCD	6
5. TERMINAL FUNCTION	7
6. LCD DRAWINGS	8
7. SEGMENT DEFINITION TABLE	10
8. COMMAND SUMMARY	11
9. RELIABILITY	12
10. HANDLING PRECAUTIONS	13



1. FEATURES

- * **Display mode:** FSTN /Positive / Transflective
- * **Backlight:** White LED
- * **Display Format:** Digital with 7, 14 & 16 segment characters, bar graph and icons.
- * **IC:** KickStart™ KS480
- * **Interface Input Data:** I²C, SPI (4 Wire)
- * **Driving Method:** 1/8 Duty, 1/4 Bias
- * **Viewing Direction:** 6 'CLOCK

2. MECHANICAL SPECIFICATIONS

Item	Specification	Unit
Dimensional Outline	81.5L x 67.5W x 6.0H	mm
LCD Size	63.5L x 58.0/60.5W x 2.0H MAX	mm
Viewing Area	58.5 x 52.0	mm
Character Font	Digital	-
Operating Temp.	-20~+70	°C
Storage Temp.	-30~+80	°C
Weight	28	g

3. ELECTRICAL SPECIFICATION

3.1. Absolute Maximum Ratings (V_{SS} = 0V)

Item	Symbol	Standard Value			Unit
		Min.	Typ.	Max.	
Supply Voltage For Logic	V _{DD} -V _{SS}	-	-	<6.0	V
Supply Voltage For LCD Drive	V ₀ -V _{SS}	3.8	4	4.2	V
Input Voltage Range	V _{in}	-0.5	-	V _{DD} +0.5	V

Note 1) V_{DD} based on V_{SS} = 0V



3.2. Electrical Characteristics ($V_{SS} = 0V$)

Item	Symbol	Test Condition	Min.	Typ.	Max.	Unit	
Logic Supply Voltage	$V_{DD} - V_{SS}$	-	2.6	3.0	3.6	V	
LCD Drive Voltage (Recommended Voltage)	V_{LCD}	-	3.8	4.0	4.2	V	
Input Voltage	"H" Level	V_{IH}	$V_{DD}=3.0V+5\%$	2.0	-	-	V
	"L" Level	V_{IL}		0	-	0.8	
Output Voltage	"H" Level	V_{OH}	$V_{DD}=3.0V+5\%$		3.5		V
	"L" Level	V_{OL}			1.0		
Operating current	I_{OP}	$V_{DD} = 3V$	-	1700	2000	μA	
SLEEP current (LCD on, no wakeup)	I_{SLEEP3}	$V_{DD} = 3V$	-	26	-	μA	
SLEEP current (LCD on, RTC on, autoprint)	I_{SLEEP2}	$V_{DD} = 3V$	-	28	-	μA	
SLEEP current (LCD off , RTC on)	I_{SLEEP1}	$V_{DD} = 3V$	-	6	-	μA	
DEEPSLEEP current	$I_{DEEPSLEEP}$	$V_{DD} = 3V$	-	0.8	1	μA	



4. ELECTRO-OPTICAL CHARACTERISTICS OF LCD

Item	Symbol	Temp.	Min.	Typ.	Max.	Unit	Conditions	Note
Driving Voltage	V_{OP}	25	3.8	4.0	4.2	V	-	Note 1
Viewing Angle ($Cr \geq 2$)	$\theta(\Phi=0^\circ)$	25	-	-	40	Degree	-	Note 1 Note 2
	$\theta(\Phi=180^\circ)$		-20	-	-			
	$\theta(\Phi=90^\circ)$		-40	-	-			
	$\theta(\Phi=270^\circ)$		-	-	35			
Contrast Ratio	Cr	25	-	4	7	-	-	Note 3
Frame Frequency	Ff	25	32	64	128	Hz	-	-
Response Time (rise)	Tr	25	-	80	160	ms	-	Note 4
		50	-	50	100			
Response Time (fall)	Tf	25	-	100	200	ms	-	
		50	-	60	120			

Note1 . Definition of Angle θ_1 & θ_2

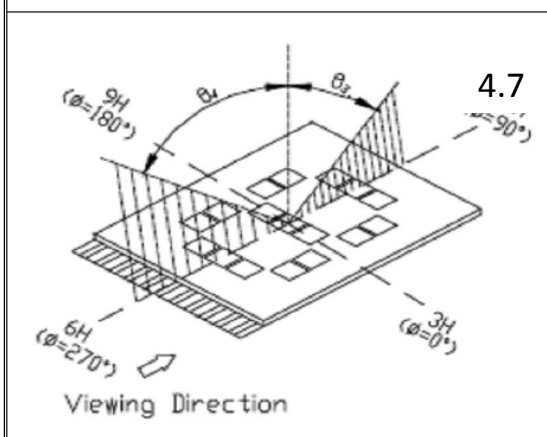

Note2. Definition of Viewing Angle θ_1 & θ_2

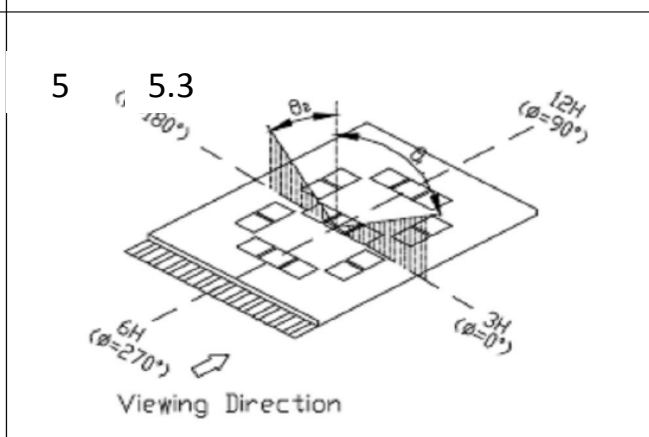

Note3 . Definition of Contrast Cr

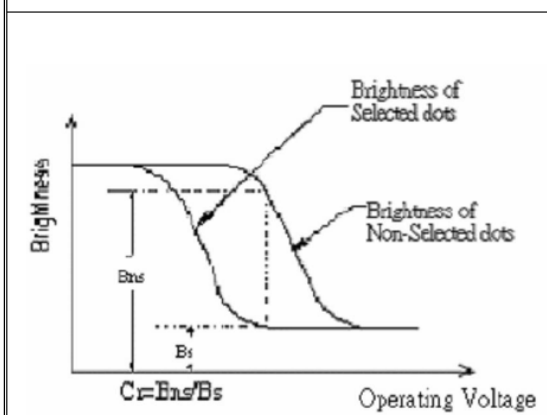

Note4. Definition of Optical Response

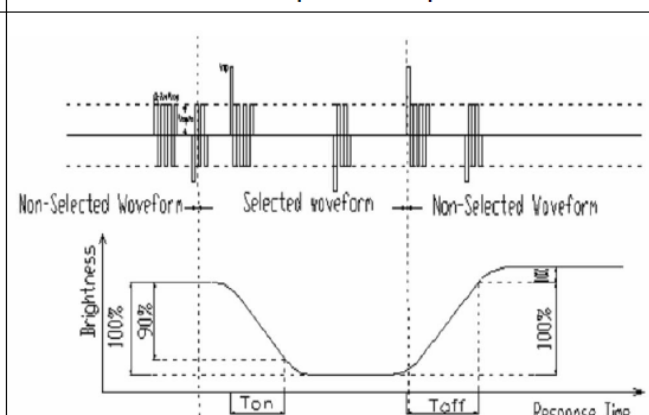



5. TERMINAL FUNCTION

Pin	Symbol	Function Description
1	GND	Ground
2	GND	Ground
3	VCC	Supply for IC logic voltage +5V
4	VCC	Supply for IC logic voltage +5V
5	BUSMODE	Interface select
6	CS/SDA	IC select or data input
7	CK	Clock input
8	DI/LED3	Data input
9	D0/LED4	Data input
10	EVENT	Data input
11	KEYIN1	Switch input
12	KEYIN2	Switch input
13	KEYIN3	Switch input
14	KEYIN4	Switch input
15	KEYIN5	Switch input
16	LED1/BL	BL or LED input
17	LED2	LED input
18	BUZZER/LED5	BUZZER or LED input
19	BUZZER/LED6	BUZZER or LED input
20	NC	(Factory use only)



6. LCD DRAWINGS

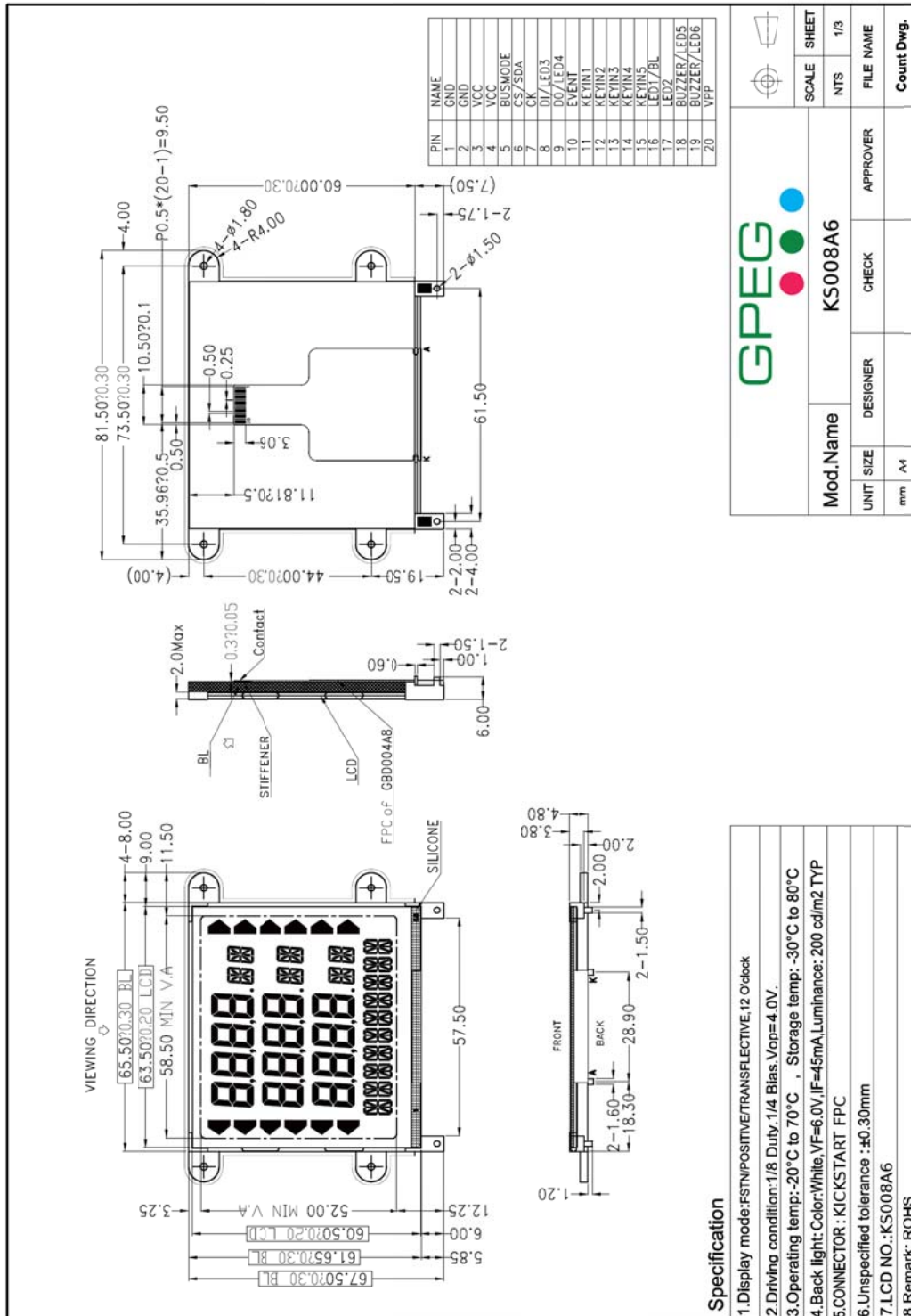

GPEG International Ltd

9 Gunnery Terrace, Duke of Wellington Avenue, Royal Arsenal,
Woolwich, London. SE18 6SW, United Kingdom

Ph: +44 8704 931 433, Fax: +44 208 181 6751

www.gpegint.com sales@gpegint.com



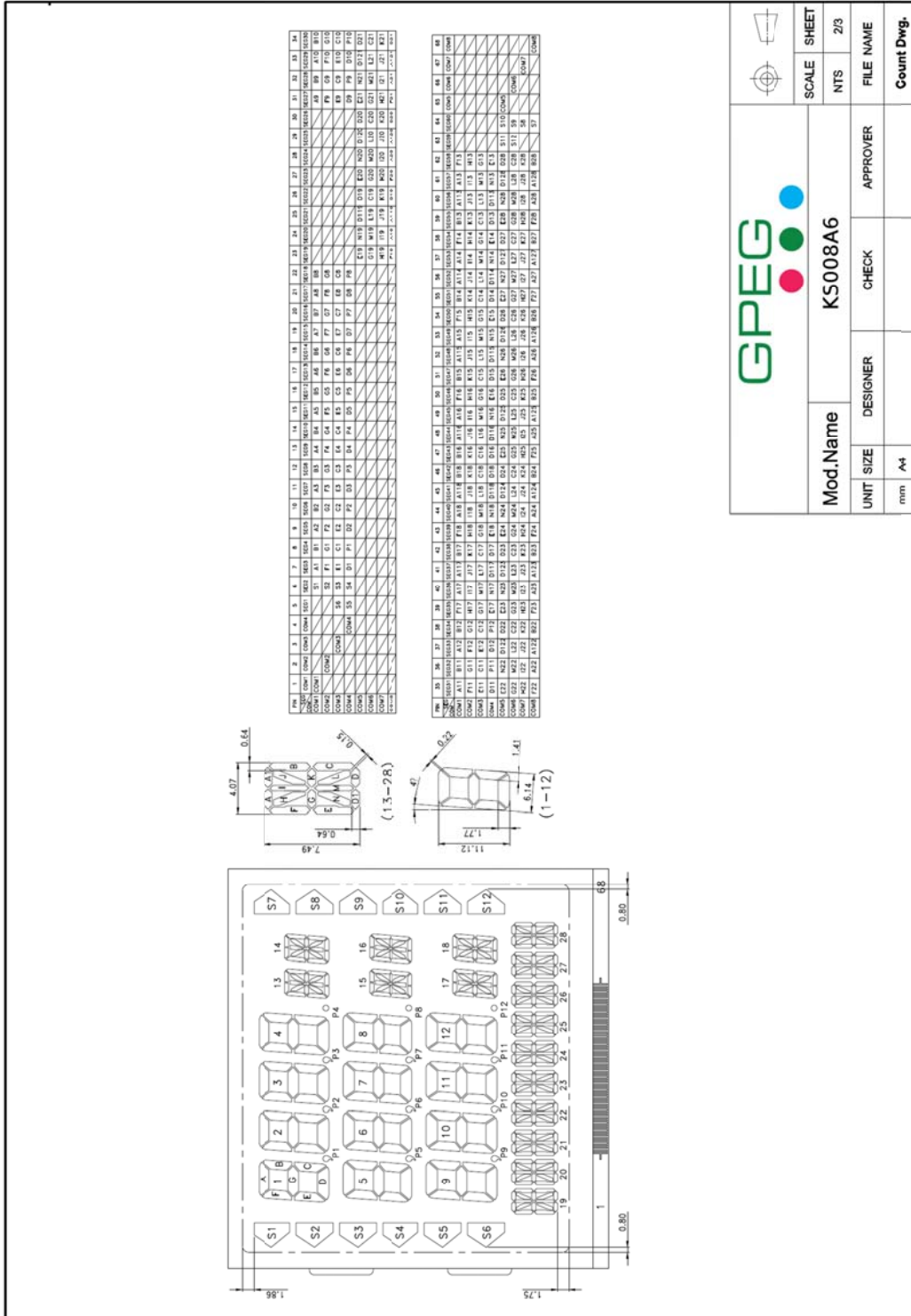

		SCALE	SHEET
		NTS	2/3
Mod.Name		KS008A6	
UNIT	SIZE	DESIGNER	APPROVER
mm	A4		
COUNT		COUNT	



7. SEGMENT DEFINITION TABLE

This information is needed to access the LCD controller at segment level.

Number	Name	Number	Name	Number	Name	Number	Name	Number	Name
0	1A	50	6A	100	11M	150	14K	200	N2
1	1B	51	6B	101	11L	151	15C	201	N3
2	1C	52	6C	102	11K	152	15D	202	N4
3	1D	53	6D	103	12C	153	15E	203	N5
4	1E	54	6E	104	12D	154	15C	204	N6
5	1F	55	6F	105	12E	155	15D	205	N7
6	1G	56	6G	106	12C	156	15D1	206	N8
7	1G1	57	7A	107	12D	157	15E	207	N9
8	1H	58	7B	108	12D1	158	15F	208	N10
9	1I	59	7C	109	12E	159	15G	209	N11
10	1J	60	7D	110	12F	160	15G1	210	N12
11	1K	61	7E	111	12G	161	15H	211	X1
12	1L	62	7F	112	12G1	162	15I	212	X2
13	1M	63	7G	113	12H	163	15J	213	X3
14	2A	64	8A	114	12I	164	15M	214	X4
15	2B	65	8B	115	12J	165	15L	215	X5
16	2C	66	8C	116	12M	166	15K	216	X6
17	2D	67	8D	117	12L	167	16C	217	X7
18	2E	68	8E	118	12K	168	16D	218	X8
19	2F	69	8F	119	13C	169	16E	219	X9
20	2G	70	8G	120	13D	170	16C	220	X10
21	2G1	71	9A	121	13E	171	16D	221	X11
22	2H	72	9B	122	13C	172	16D1	222	S1
23	2I	73	9C	123	13D	173	16E	223	S2
24	2J	74	9D	124	13D1	174	16F	224	S3
25	2K	75	9E	125	13E	175	16G	225	S4
26	2L	76	9F	126	13F	176	16G1	226	S5
27	2M	77	9G	127	13G	177	16H	227	lock
28	3A	78	10A	128	13G1	178	16I	228	sun
29	3B	79	10B	129	13H	179	16J	229	alam
30	3C	80	10C	130	13I	180	16M	230	clock
31	3D	81	10D	131	13J	181	16L	231	min
32	3E	82	10E	132	13M	182	16K	232	hr
33	3F	83	10F	133	13L	183	17C	233	F
34	3G	84	10G	134	13K	184	17D	234	C
35	4A	85	6P	135	14C	185	17E	235	mph
36	4B	86	8P	136	14D	186	17C	236	kph
37	4C	87	11C	137	14E	187	17D	237	frame
38	4D	88	11D	138	14C	188	17D1		
39	4E	89	11E	139	14D	189	17E		
40	4F	90	11C	140	14D1	190	17F		
41	4G	91	11D	141	14E	191	17G		
42	2P	92	11D1	142	14F	192	17G1		
43	5A	93	11E	143	14G	193	17H		
44	5B	94	11F	144	14G1	194	17I		
45	5C	95	11G	145	14H	195	17J		
46	5D	96	11G1	146	14I	196	17M		
47	5E	97	11H	147	14J	197	17L		
48	5F	98	11I	148	14M	198	17K		
49	5G	99	11J	149	14L	199	N1		



8. COMMAND SUMMARY

Normal commands have a general format of:

command, length, payload[], checksum

Symbol	Length	Description
command	1 byte	Command code
length	1 byte	Length of payload[]
payload[]	length	Meaning depends on command code
checksum	1 byte	Sum of all bytes starting from command plus 128

List of commands

Code	Symbol	Description
1	Cmd_Seg_Tbl	Load LCD Segment Table
2	Cmd_Obj_Tbl	Load LCD Object Table
3	Cmd_ScrollTxt	Load text for automatic scrolling
16	Cmd_LCD_cnf	Set commons of glass, bias, object count
17	Cmd_Contrast	Set LCD contrast level
18	Cmd_Statread	Read status bytes. Only for SPI mode!
19	Cmd_Reset	Reset KickStart™ LCD Controller
20	Cmd_Set_Seg	Set logical segment on
21	Cmd_Clr_Seg	Set logical segment off
22	Cmd_Obj_W	Write object without conversion
23	Cmd_7seg	Set a 7-segment object to a value
24	Cmd_14seg	Set a 14-segment object to a value
25	Cmd_16seg	Set a 16-segment object to a value
27	Cmd_Bar	Set a bar object to a value
28	Cmd_7seg_Str	Set a 7-segment component to a value
29	Cmd_14seg_Str	Set a 14-segment component to a value
30	Cmd_16seg_Str	Set a 16-segment component to a value
32	Cmd_Bar_Str	Set a bargraph component to a value
33	Cmd_Shift_L	Shifts the values of a component left by one object
34	Cmd_Shift_R	Shifts the values of a component right by one object
35	Cmd_Scroll2Hz	Controls automatic scrolling
36	Cmd_RTC	Set RTC mode, date/time, events, auto-display
37	Cmd_Attr	Set attribute of a component
38	Cmd_LED	Set one LED, including the backlight, on or off
39	Cmd_Buzz	Turn on/off buzzer, set output-mode, frequency
40	Cmd_LCD_OnOff	Turn the LCD on or off
41	Cmd_TestLED	Turn on or off the test functions of the LEDs
42	Cmd_AllSeg_On	Turn on all segments
43	Cmd_AllSeg_Off	Turn off all segments
44	Cmd_Sleep	Set KickStart™ power mode
45	Cmd_SleepLED1	Enable sleep mode indicator function of LED1

Full descriptions of the command set can be found in the KickStart™ User's Manual.



9. RELIABILITY

NO.	Item	Condition	Criterion
1	High Humidity	40°C, 90%RH, 96Hrs	All test conditions in state, not operating.
2	High Temperature Storage	60°C, 96Hrs	
3	Low Temperature Storage	-20°C, 96Hrs	
4	Thermal Shock	-20°C to 25°C to 60°C to 25°C (30Min)(5Min)(30Min)(5Min) 5Cycles	

Note: 1) For restricted products, the test conditions listed as above must be revised.



10. HANDLING PRECAUTIONS

1) Mounting Method

The panel of the LCD Module consists of two thin glass plates with polarizers which easily get damaged since the module is fixed by utilising fitting holes in the printed circuit board. Extreme care should be taken when handling the LCD modules.

2) Caution when handling & cleaning the LCD

When cleaning the display surface, use a soft cloth with solvent (recommended below) and wipe lightly:

- Isopropyl alcohol
- Ethyl Alcohol
- Trichlorotrifluoroethane

Do not wipe the display surface with dry or hard materials that will damage the polarizer surface.

Do not use the following:

- Water
- Acetone
- Aromatics

3) Caution against static charge

The LCD module uses CMOS LSI drivers, so we recommend that you connect any unused input terminal to VDD or VSS, do not input any signals before power is turned on, ground your body, work/assembly table and assembly equipment to protect against static electricity.

4) Packaging

- Modules use LCD elements and must be treated as such. Avoid intense shock and falls from a height.
- To prevent modules from degradation, do not operate or store exposed directly to sunshine or high temperature/humidity.

5) Caution when operating

- It is essential to drive LCD within the specified voltage limit. Driving at a higher voltage will significantly shorten the LCD's lifespan. An electrochemical reaction due to direct current causes LCD deterioration, avoid the use of direct current drive.
- Response time will be extremely delayed at lower temperatures than the operating temperature range. At higher temperatures, the LCDs will show dark colours in them. These phenomena do not mean a faulty LCD; it will return to its normal operation when back within the specified operating temperature range.
- If the display area is pushed hard during operation, some characters may be abnormally displayed. They will resume their normal condition after turning off the LCD once.
- A slight dew depositing on terminals is a cause for electrochemical reactions resulting in terminal open circuit. Usage under the relative condition of 40°C, 50%RH or less is required.

6) Storage

In the case of storing for long periods of time (i.e. Years) for the purpose of replacement use, the following method is recommended.



- Store in a sealed, airtight, polyethylene bag. Do not use desiccant.
- Store in a dark place away from exposure to direct sunlight.
- Store within the specified storage temperature range.
- Do not store with anything pressing on the polarizer surface. It is recommended to store the LCD as they have been contained in the inner container at the time of delivery.

7) Safety

- It is recommended to crush damaged or unnecessary LCDs into pieces and wash off the liquid crystal using solvents such as acetone and ethanol to be burned up later.
- Any liquid crystal from damaged glass that comes in contacts with hands must be washed off thoroughly with soap and water.