

# Dimmable Constant Current LED Drivers

## IZC0xx-018T Series

### Product Overview

IZC0xx-018T Series are a range of RoHS compliant single output Constant Current power supplies, of non waterproof design, suitable for indoor LED lighting applications with triac dimming function.

### Technical Features:

- Captive terminal screws for ease of installation
- Snap lock cable strain relief
- Over load/short circuit and thermal protection
- Triac Dimming 1-100%
- Leading and trailing edge operation
- Class II product

### Applications:

- Residential LED lighting
- Retail Lighting
- LED downlights
- LED Backlighting
- Mood lighting
- Light sculptures



### Product Options

ILS PART NUMBER	Voltage	Current	Power	LED Config.	Operating Temperature	Dimensions
IZC070-018T-9500A-SA	6V-26V	700mA	18W	2-7 White LEDs	-20°C to +50°C	L113xW44xH28mm
IZC050-018T-9500A-SA	9-36V	500mA	18W	3-10 White LEDs	-20°C to +50°C	L113xW44xH28mm
IZC035-018T-9500A-SA	15-52V	350mA	18W	5-14 White LEDs	-20°C to +50°C	L113xW44xH28mm

### Specification

● IP Rating	IP20
● Input Voltage	220-240V
● Input Frequency	50Hz to 60Hz
● Power Factor	0.95
● Efficiency	higher than 80%
● Set Up Time	< 2s
● Over Load Protection	100-135% of rated output power
● Over Temperature Protection	Thermal shutdown
● Dimming Control	Triac controlled 1-100%
● Storage Temperature	-20°C to +80°C
● Lifetime	50K hours full load 25°C
● Safety Standards	Designed to meet EN61347-1:2001/EN61347-2-13:2001
● EMI Standards	Meets Emissions to EN 55105,EN61547
● Weight	108g
● Input Connections	Screw terminal
● Output Connections	Screw terminal

### Technical Drawing

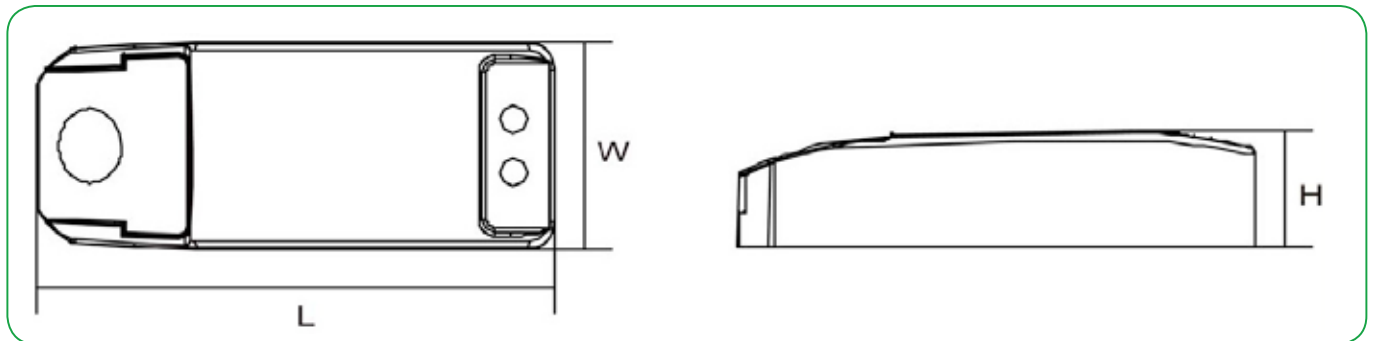

### LED Configuration

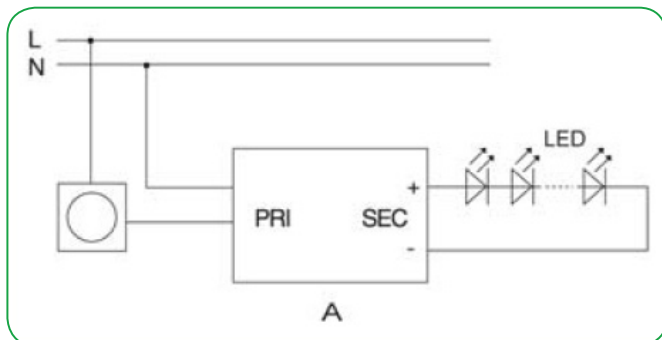

### For further information please contact ILS

The values contained in this data sheet can change due to technical innovations. Any such changes will be made without separate notification.