

COMPACT DESIGN



Full Boot Shown

Half Boot with P9 Pushbutton Shown

The JHT miniature series Hall Effect joystick's compact design and robust construction is the ideal solution where space is limited and precision control is required. Ideal applications include: robotics, construction equipment, hydraulic controls, medical and surgery equipment, security and surveillance video cameras. The JHT has been tested to five million cycles with no degradation of electrical performance or boot wear. Electronics are sealed to IP68S and the EMI/RFI withstand are per SAE J1113 specifications.

Features:

- Compact design excellent for armrest & panel mounting
- Proven contactless analog output Hall effect technology
- 5 million operational cycles in all directions
- Electronics sealed per IP68S
- Single or omni-directional
- Optional pushbutton switch(es) available
- RoHS/WEEE/Reach compliant

Standard Characteristics/Ratings:				
GENERAL:				
Sensor Type:	Hall effect analog, factory programmed ground and supply line break detection; over voltage and reverse voltage protection			
Design:	Contactless sensing			
ELECTRICAL RATINGS: Rated at Vcc = 5V @ 20°C Load = 1ma (4.7KΩ)				
Electrical				
	Units	Min	Typ	Max
Supply Voltage	VDC	4.5	5	5.5
Output Voltage Tolerance at Center	VDC @ 5V Vcc	- .25	N/A	+ .25
Output Voltage Tolerance Full Travel	VDC @ 5V Vcc	- .25	N/A	+ .25
Supply Current* (B = 0, Vcc = 5V, Io = 0)	mA	N/A	10	12
Output Impedance	kΩ	N/A	1	N/A
*Single output per axis. Dual axis per output available. Supply current 20mA typical.				
MECHANICAL:				
Joystick Mechanical Life: 5,000,000 cycles in all directions				
P9 Mechanical Life: 1,000,000 cycles				
Travel Angle: 18° min to 22° max, 20° typical				
Overtravel Angle: 0.5° min to 1.5° max, 1° typical				
Joystick Operating Force: With bellows, at grip 0.5 lb. min to 1.5 lbs. max over temperature range				
P9 Operating Force: @20°C 8 oz min to 16 oz max, 12 oz typical				
ENVIRONMENTAL:				
Operating Temp Range: -40°C to +85°C				
Seal: Electronics seal to IP68S				
RFI/EMI: Withstand per SAE J1113				
MATERIALS:				
Housing: Thermoplastic, black				
Bellows: Silicone, black. Additional materials available, contact factory.				

JHT PART NUMBER CODE

JHT	-	XX	X	X	XX	X	X	X		
Switch/Boot Style			Gating*		Operating Force		Output 1	Output 2	Termination	P9 Button Color**
11. With P9 Pushbutton & Full Boot			1. Gated, Single axis – Return to Center		1. 1 lb		AA. 2.5 +/- 2.0VDC	NONE	1. 24 AWG Wire Leads	N. None
12. With P9 Pushbutton & Half Boot			3. Omni-directional; Round Smooth Feel				BB. 2.5 +/- 2.0VDC	2.5 +/- 2.0VDC		1. Red
21. Without Pushbutton & Full Boot			4. Omni-directional; On-Axis and Off-Axis Guided Feel				CC. 2.5 +/- 2.0VDC	2.5 +/- 2.0VDC		2. Black
			5. Omni-directional; Round On-Axis Guided Feel				DD. 2.5 +/- 1.5VDC	NONE		3. Orange
							EE. 2.5 +/- 1.5VDC	2.5 +/- 1.5VDC		4. Yellow
							FF. 2.5 +/- 1.5VDC	2.5 +/- 1.5VDC		5. Green
							GG. 0.5 - 4.5VDC	0.5 - 4.5VDC		6. Blue
							HH. 1.0 - 4.0VDC	1.0 - 4.0VDC		7. Purple
										8. Gray
										9. White

*Gated = Restricted movement in XY axis only. Gating icons appear on page 69.

**Applies only to half boot with pushbutton option

NOTES:

- Outputs are from the center to the full travel position in each direction.
- Options "AA," "BB," "CC," "DD," "EE" and "FF" provide increased voltage in +X, +Y; and decreasing voltage in -X, -Y direction from one output per axis.
- Options "GG" and "HH" provide increasing voltages in all directions (+X, +Y, -X, -Y) from 2 outputs per axis.
- Options "BB" and "EE" provide redundant output 2 which duplicates output 1. Options "CC" and "FF" provide redundant output 2 which is inverse of output 1.

MINIATURE HALL EFFECT JOYSTICK

COMPACT DESIGN

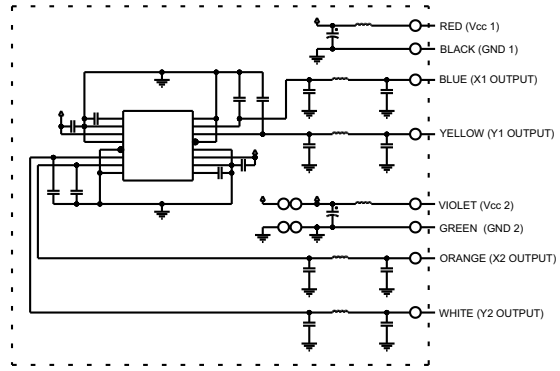
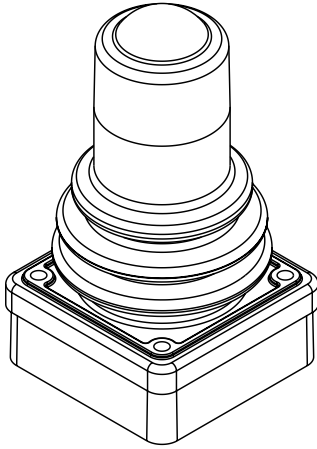

GENERAL SCHEMATIC

(WIRE BUNDLE 1)
ALL OUTPUTS ARE NOT PRESENT IN ALL CONFIGURATIONS

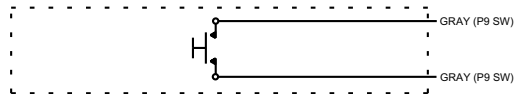

PUSHBUTTON SCHEMATIC

(WIRE BUNDLE 2)
ALL WIRES ARE NOT PRESENT IN ALL CONFIGURATIONS

Full Boot Version Shown

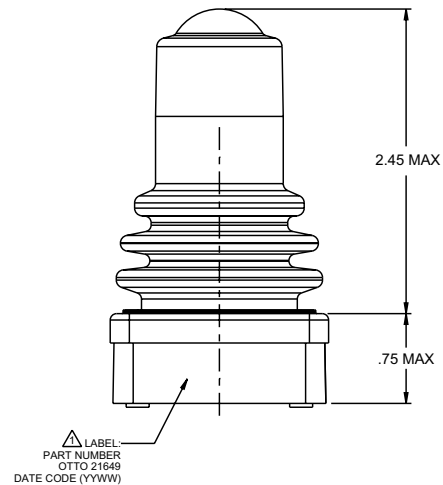
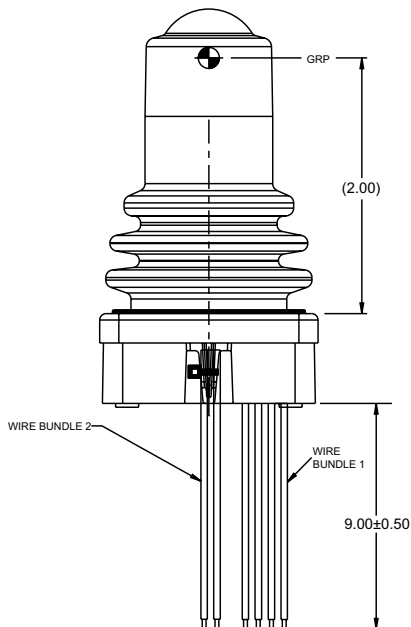
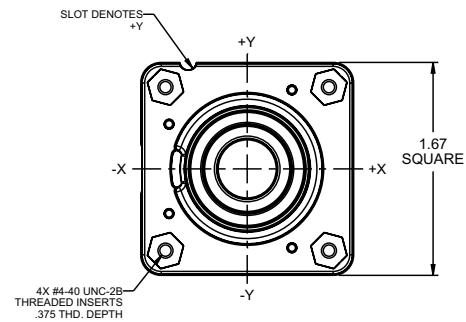
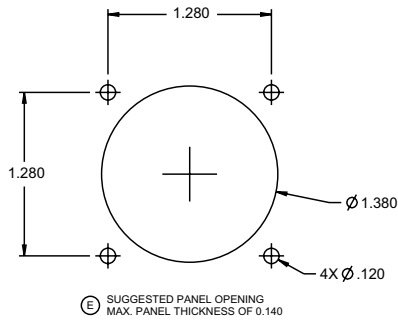

COMPACT DESIGN

JHT Switch/Style Boot Configuration

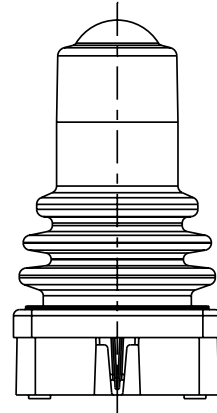
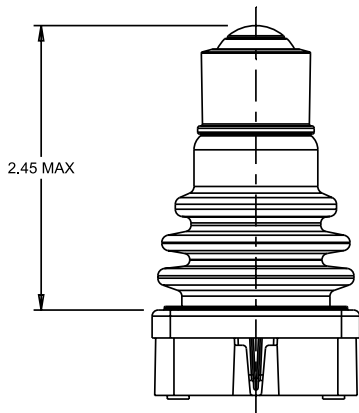
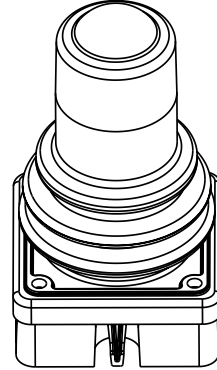
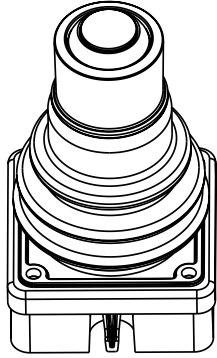

HALF BOOT

FULL BOOT

JHT and JHT Z-Axis Icons Demonstrating Feel*

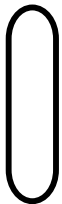

Single Axis

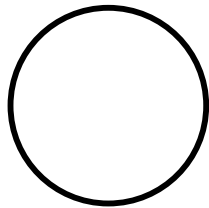

Omnidirectional
Round Smooth Feel

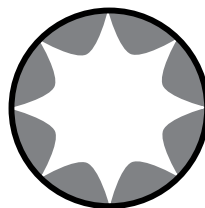

Omnidirectional
On-Axis and Off-Axis
Guided Feel**

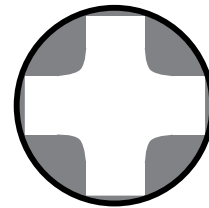

Omnidirectional
Round On-Axis
Guided Feel

*Feel defined by shading.

**Full output available in all directions. Contact factory for details.

MINIATURE HALL EFFECT JOYSTICK

JHT
MINI
JOYSTICK

COMPACT DESIGN

OPTION AA

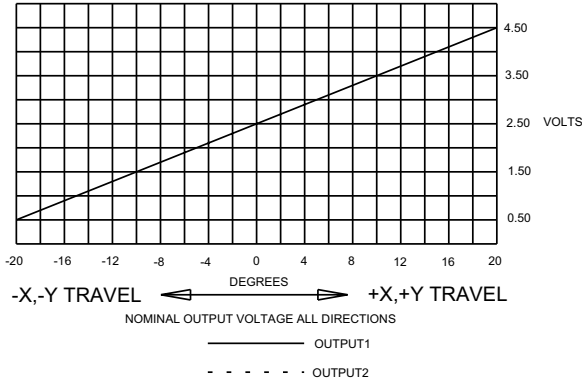

OPTION BB

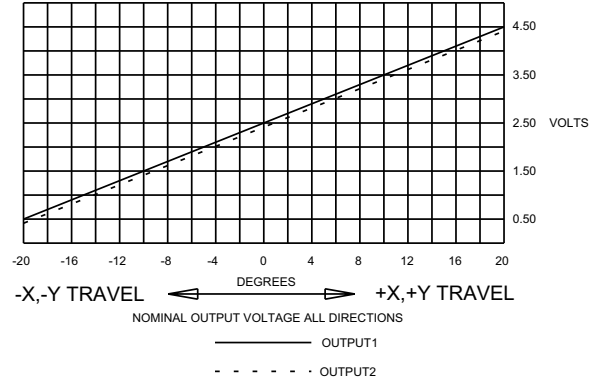

OPTION DD

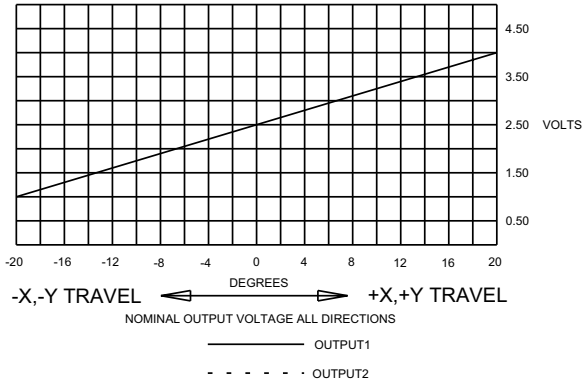

OPTION CC

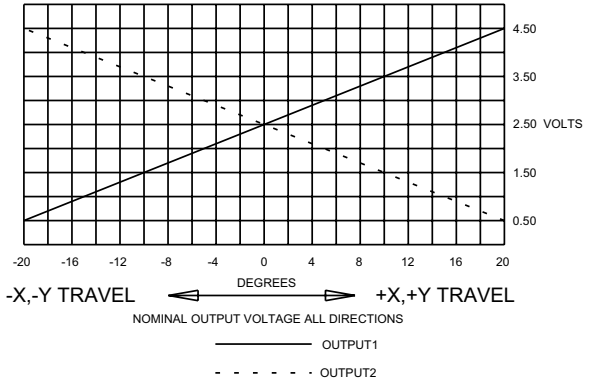

OPTION EE

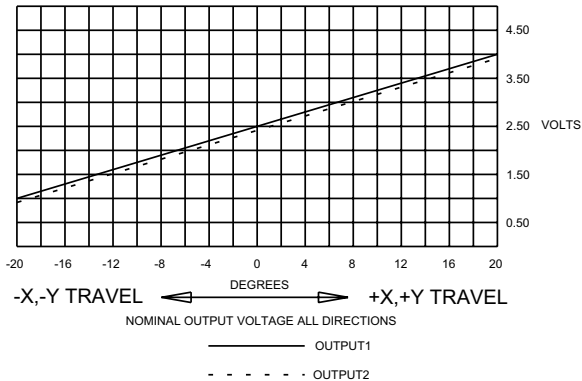

OPTION FF

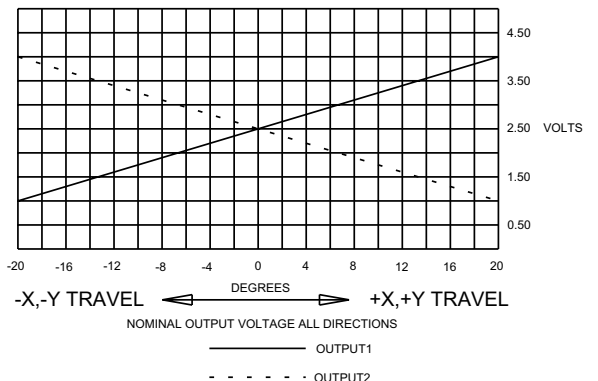

OPTION GG

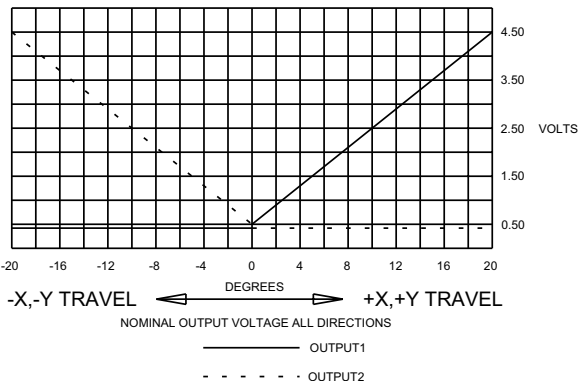

OPTION HH

