

1591E Enclosure

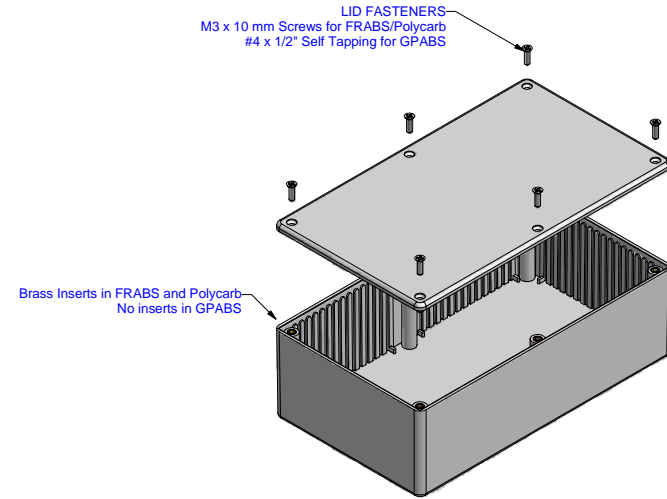

EXPLODED VIEW OF ASSEMBLY

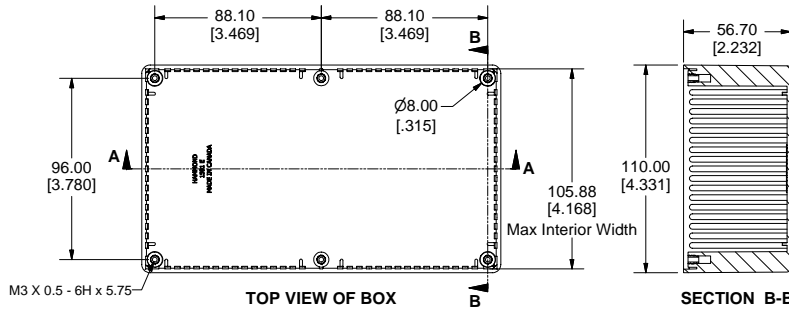
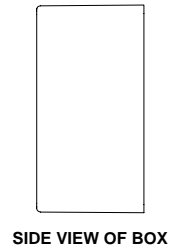
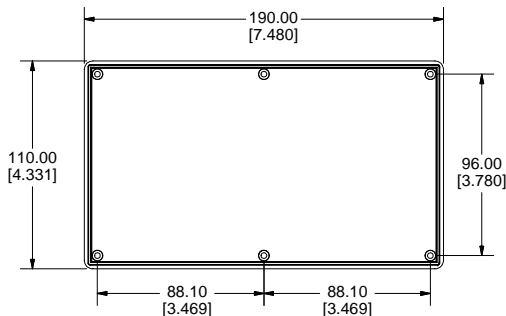
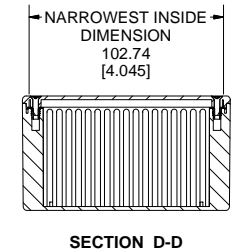
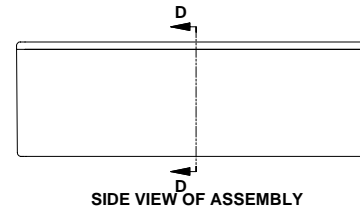
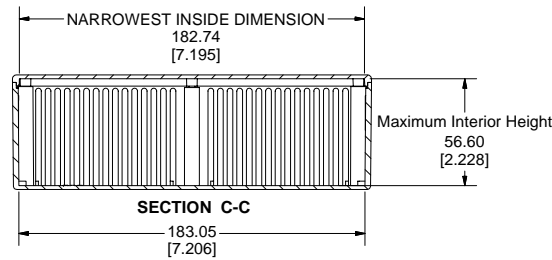
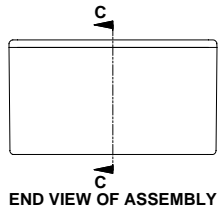
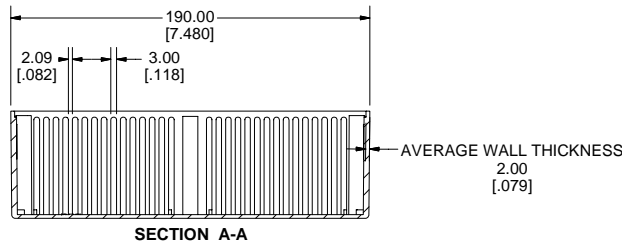

BOTTOM OF LID

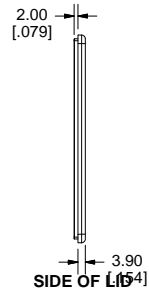

SIDE OF LID

Note:
Enclosures can be Factory Modified (Milling, Drilling, Printing etc.)
Solid models of this enclosure available in STEP or IGES Format.
Contact Factory mjm@hammondmfg.com



PART NUMBERS		
1591E Enclosures		
Material	Colour	Part Number
FR ABS UL94 - V0	Black	1591EBK
	Grey	1591EGY
GP ABS	Black Shielded (Conductive Paint)	1591REBK
	Black	1591ESBK
Translucent Polycarbonate	Grey	1591ESGY
	Ice Blue	1591ETBU
Polycarbonate	IR Red	1591ETRD
	Crystal Clear	1591ETCL
Accessories		
	Description	Part Number
Universal Application	PC Board Card Adapters	See Accessories Section
	Flange Kits	See Accessories Section
	Clear Lids - clear, flame retardant polycarbonate - Lid ONLY	1591EC
FR ABS & Polycarbonate	Replacement Screws, Flat head Phillips, Nickel Plated Pkg of 100	1591MS100
GP ABS	Self Tapping Pkg of 100	1591MS100BK (Black)
		1591TS100
	1591TS100BK (Black)	
Required Torque on Fasteners (no lubrication)		
	M3 - 0.5 x 10mm Screws	30-40 cN*m
	#4 x 0.5 Screws	30-40 cN*m