

High precision rail-to-rail operational amplifier

Features

- Ultra low offset voltage: 25 μ V typ, 100 μ V max
- Rail-to-rail input/output voltage swing
- Operating from 2.7V to 5.5V
- High speed: 1.9MHz
- 45° phase margin with 100pF
- Low consumption: 0.8mA at 2.7V
- Very large signal voltage gain: 131dB
- High power supply rejection ratio: 105dB
- Very high ESD protection 5kV (HBM)
- Latch-up immunity
- Available in SOT23-5 micropackage

Applications

- Battery-powered applications
- Portable devices
- Signal conditioning
- Medical instrumentation
- Automotive

Description

The TS507 is a high performance rail-to-rail input and output amplifier with very low offset voltage. This amplifier uses a new trimming technique that yields ultra low offset voltages without any need for external zeroing.

The circuit presents very stable electrical characteristics over the entire supply voltage range, and is particularly intended for automotive and industrial applications.

The TS507 is housed in the space-saving 5-pin SOT23 package, making it well suited to battery-powered systems. This micropackage simplifies the PC board design because of its ability to be placed in tight spaces (external dimensions are 2.8mm x 2.9mm).

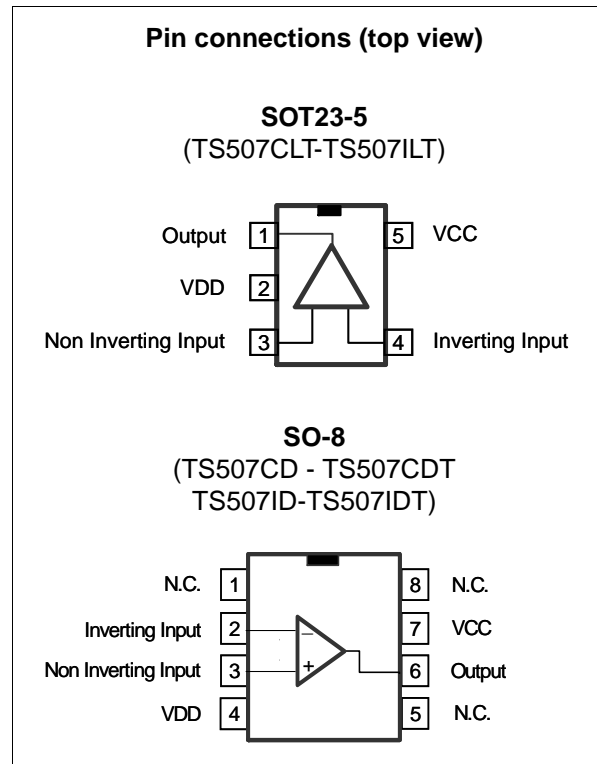

Contents

1	Absolute maximum ratings and operating conditions	3
2	Electrical characteristics	5
3	Package mechanical data	15
3.1	SOT23-5 package	16
3.2	SO-8 package	17
4	Ordering information	18
5	Revision history	18

1 Absolute maximum ratings and operating conditions

Table 1. Absolute maximum ratings (AMR)

Symbol	Parameter	Value	Unit
V_{CC}	Supply voltage ⁽¹⁾	6	V
V_{id}	Differential input voltage ⁽²⁾	± 2.5	V
V_{in}	Input voltage ⁽³⁾	$V_{DD}-0.3$ to $V_{CC}+0.3$	V
T_{stg}	Storage temperature	-65 to +150	°C
R_{thja}	Thermal resistance junction to ambient ^{(4) (5)}		°C/W
	SOT23-5	250	
	SO-8	125	
R_{thjc}	Thermal resistance junction to case		°C/W
	SOT23-5	81	
	SO-8	40	
T_j	Maximum junction temperature	150	°C
ESD	HBM: human body model ⁽⁶⁾	5	kV
	MM: machine model ⁽⁷⁾	300	V
	CDM: charged device model ⁽⁸⁾	2	kV
	Latch-up immunity	class A	

1. Value with respect to V_{DD} pin.
2. Differential voltages are the non-inverting input terminal with respect to the inverting input terminal.
3. $V_{CC}-V_{in}$ must not exceed 6V and V_{in} must not exceed 6V.
4. Short-circuits can cause excessive heating and destructive dissipation.
5. $R_{thja/c}$ are typical values.
6. Human body model: A 100pF capacitor is charged to the specified voltage, then discharged through a 1.5k Ω resistor between two pins of the device. This is done for all couples of connected pin combinations while the other pins are floating.
7. Machine model: A 200pF capacitor is charged to the specified voltage, then discharged directly between two pins of the device with no external series resistor (internal resistor < 5 Ω). This is done for all couples of connected pin combinations while the other pins are floating.
8. Charged device model: all pins and the package are charged together to the specified voltage and then discharged directly to the ground through only one pin. This is done for all pins.

Table 2. Operating conditions

Symbol	Parameter	Value	Unit
V_{CC}	Supply voltage ⁽¹⁾	2.7 to 5.5	V
V_{icm}	Common mode input voltage range	V_{DD} to V_{CC}	V
V_{id}	Differential input voltage ⁽²⁾	± 2.5	V
T_{oper}	Operating free air temperature range TS507C TS507I	0 to +85 -40 to +125	°C

1. Value with respect to V_{DD} pin.

2. Differential voltages are the non-inverting input terminal with respect to the inverting input terminal.

2 Electrical characteristics

Table 3. Electrical characteristics at $V_{CC} = +5V$, $V_{DD} = 0V$, $V_{icm} = V_{CC}/2$, $T_{amb} = 25^{\circ}C$, R_L connected to $V_{CC}/2$ (unless otherwise specified)⁽¹⁾

Symbol	Parameter	Conditions	Min.	Typ.	Max.	Unit
DC performance						
V_{io}	Input offset voltage ⁽²⁾	$V_{icm} = 0$ to 3.8V, $T = 25^{\circ}C$ TS507C full temp range TS507I full temp range		25	100 250 400	μV
		$V_{icm} = 0V$ to 5V, $T = 25^{\circ}C$ TS507C full temp range TS507I full temp range			450 550 750	μV
$\Delta V_{io}/\Delta t$	V_{io} drift vs. temperature	$T_{min} < T_{op} < T_{max}$		1		$\mu V/^{\circ}C$
I_{ib}	Input bias current	$T = 25^{\circ}C$ TS507C full temp range TS507I full temp range		8	70 75 110	nA
I_{io}	Input offset current	$T = 25^{\circ}C$ TS507C full temp range TS507I full temp range		2	25 35 50	nA
CMRR	Common mode rejection ratio $20 \log (\Delta V_{icm}/\Delta V_{io})$	V_{icm} from 0V to 3.8V, $T = 25^{\circ}C$ TS507C full temp range TS507I full temp range	94 94 91	115		dB
		V_{icm} from 0V to 5V		96		
PSRR	Power supply rejection ratio $20 \log (\Delta V_{CC}/\Delta V_{io})$	V_{CC} from 2.7V to 5.5V, $V_{icm} = V_{CC}/2$, $T = 25^{\circ}C$ TS507C full temp range TS507I full temp range	91 90 89	105		dB
A_{vd}	Large signal voltage gain	$R_L = 10k\Omega$, $V_{out} = 0.5V$ to 4.5V Full temp range	99 98	131		dB
$V_{CC}-V_{OH}$	High level output voltage drop	$R_L = 600\Omega$, $T = 25^{\circ}C$ TS507C full temp range TS507I full temp range		67	95 110 120	mV
		$R_L = 10k\Omega$, $T = 25^{\circ}C$ Full temp range		4	15 15	
V_{OL}	Low level output voltage	$R_L = 600\Omega$, $T = 25^{\circ}C$ TS507C full temp range TS507I full temp range		64	90 110 125	mV
		$R_L = 10k\Omega$, $T = 25^{\circ}C$ Full temp range		4	15 15	

Table 3. Electrical characteristics at $V_{CC} = +5V$, $V_{DD} = 0V$, $V_{icm} = V_{CC}/2$, $T_{amb} = 25^{\circ}C$, R_L connected to $V_{CC}/2$ (unless otherwise specified)⁽¹⁾ (continued)

Symbol	Parameter	Conditions	Min.	Typ.	Max.	Unit
I_{out}	I_{sink}	$V_{out} = V_{CC}$, $V_{id} = -1V$, $T = 25^{\circ}C$ TS507C full temp range TS507I full temp range	74 60 53	104		mA
	I_{source}	$V_{out} = V_{DD}$, $V_{id} = 1V$, $T = 25^{\circ}C$ TS507C full temp range TS507I full temp range	90 77 70	128		
I_{CC}	Supply current (per operator) ⁽²⁾	No load, $V_{out} = V_{CC}/2$, $V_{icm} = 0$ to 5V, $T = 25^{\circ}C$ Full temp range		0.85	1.15 1.25	mA
Dynamic performance						
GBP	Gain bandwidth product	$R_L = 2k\Omega$, $C_L = 100pF$, $f = 100kHz$		1.9		MHz
ϕ_m	Phase margin	$R_L = 2k\Omega$, $C_L = 100pF$		45		Degrees
SR	Slew rate	$R_L = 2k\Omega$, $C_L = 100pF$, $V_{out} = 1.25V$ to $3.75V$, 10% to 90%		0.6		V/ μs
e_N	Equivalent input noise voltage	$f = 1kHz$		12		nV/ \sqrt{Hz}
i_N	Equivalent input noise current	$f = 10kHz$		1.2		pA/ \sqrt{Hz}
THD+ e_N	THD + noise	$f = 1kHz$, $G = 1$, $R_L = 2k\Omega$, $V_{icm} = 2V$, $V_{out} = 3.5V_{pp}$		0.0003		%

1. All parameter limits at temperatures other than 25°C are guaranteed by correlation.
2. Measurements done at 4 V_{icm} values: $V_{icm} = 0V$, $V_{icm} = 3.8V$, $V_{icm} = 4.2V$, $V_{icm} = 5V$.

Table 4. Electrical characteristics at $V_{CC} = +3.3V$, $V_{DD} = 0V$, $V_{icm} = V_{CC}/2$, $T_{amb} = 25^{\circ}C$, R_L connected to $V_{CC}/2$ (unless otherwise specified)⁽¹⁾

Symbol	Parameter	Conditions	Min.	Typ.	Max.	Unit
DC performance						
V_{io}	Input offset voltage ⁽²⁾	$V_{icm} = 0$ to $2.1V$, $T = 25^{\circ}C$ TS507C full temp range TS507I full temp range		25	100 250 400	μV
		$V_{icm} = 0V$ to $3.3V$, $T = 25^{\circ}C$ TS507C full temp range TS507I full temp range			450 550 750	μV
ΔV_{io}	V_{io} drift vs. temperature	$T_{min} < T_{op} < T_{max}$		1		$\mu V/^{\circ}C$
I_{ib}	Input bias current	$T = 25^{\circ}C$ TS507C full temp range TS507I full temp range		6	70 75 145	nA
I_{io}	Input offset current	$T = 25^{\circ}C$ TS507C full temp range TS507I full temp range		2	25 40 45	nA
CMRR	Common mode rejection ratio $20 \log (\Delta V_{icm}/\Delta V_{io})$	V_{icm} from $0V$ to $2.1V$		115		dB
A_{Vd}	Large signal voltage gain	$R_L = 10k\Omega$, $V_{out} = 0.5V$ to $2.8V$		127		dB
$V_{CC}-V_{OH}$	High level output voltage drop	$R_L = 600\Omega$, $T = 25^{\circ}C$ TS507C full temp range TS507I full temp range		59	85 100 110	mV
		$R_L = 10k\Omega$, $T = 25^{\circ}C$ Full temp range		4	15 15	
V_{OL}	Low level output voltage	$R_L = 600\Omega$, $T = 25^{\circ}C$ TS507C full temp range TS507I full temp range		57	80 100 115	mV
		$R_L = 10k\Omega$, $T = 25^{\circ}C$ Full temp range		4	15 15	
I_{out}	I_{sink}	$V_{out} = V_{CC}$, $V_{id} = -1V$, $T = 25^{\circ}C$ TS507C full temp range TS507I full temp range	33 26 22	48		mA
	I_{source}	$V_{out} = V_{DD}$, $V_{id} = 1V$, $T = 25^{\circ}C$ TS507C full temp range TS507I full temp range	37 32 29	56		
I_{CC}	Supply current (per operator) ⁽²⁾	No load, $V_{out} = V_{CC}/2$, $V_{icm} = 0$ to $3.3V$, $T = 25^{\circ}C$ Full temp range		0.81	1.1 1.2	mA

Table 4. Electrical characteristics at $V_{CC} = +3.3V$, $V_{DD} = 0V$, $V_{icm} = V_{CC}/2$, $T_{amb} = 25^{\circ}C$, R_L connected to $V_{CC}/2$ (unless otherwise specified)⁽¹⁾ (continued)

Symbol	Parameter	Conditions	Min.	Typ.	Max.	Unit
Dynamic performance						
GBP	Gain bandwidth product	$R_L = 2k\Omega$, $C_L = 100pF$, $f = 100kHz$		1.9		MHz
ϕ_m	Phase margin	$R_L = 2k\Omega$, $C_L = 100pF$		45		Degrees
SR	Slew rate	$R_L = 2k\Omega$, $C_L = 100pF$, $V_{out} = 0.5V$ to $2.8V$, 10% to 90%		0.6		V/ μs
e_N	Equivalent input noise voltage	$f = 1kHz$		12		nV/ \sqrt{Hz}
THD+ e_N	THD + noise	$f=1KHz$, $G=1$, $R_L= 2k\Omega$, $V_{icm}= 1.15V$, $V_{out}= 1.8V_{pp}$		0.0004		%

1. All parameter limits at temperatures other than 25°C are guaranteed by correlation.
2. Measurements done at 4 V_{icm} values: $V_{icm} = 0V$, $V_{icm} = 2.1V$, $V_{icm} = 2.5V$, $V_{icm} = 3.3V$.

Table 5. Electrical characteristics at $V_{CC} = +2.7V$, $V_{DD} = 0V$, $V_{icm} = V_{CC}/2$, $T_{amb} = 25^{\circ}C$, R_L connected to $V_{CC}/2$ (unless otherwise specified)⁽¹⁾

Symbol	Parameter	Conditions	Min.	Typ.	Max.	Unit
DC performance						
V_{io}	Input offset voltage ⁽²⁾	$V_{icm} = 0$ to $1.9V$, $T = 25^{\circ}C$ TS507C full temp range TS507I full temp range		25	100 250 400	μV
		$V_{icm} = 0V$ to $2.7V$, $T = 25^{\circ}C$ TS507C full temp range TS507I full temp range			450 550 750	μV
ΔV_{io}	V_{io} drift vs. temperature	$T_{min.} < T_{op} < T_{ma}$		1		$\mu V/^{\circ}C$
I_{ib}	Input bias current	$T = 25^{\circ}C$ TS507C full temp range TS507I full temp range		8	70 75 160	nA
I_{io}	Input offset current	$T = 25^{\circ}C$ TS507C full temp range TS507I full temp range		2	25 45 45	nA
CMRR	Common mode rejection ratio $20 \log (\Delta V_{icm}/\Delta V_{io})$	V_{icm} from $0V$ to $1.5V$		115		dB
A_{Vd}	Large signal voltage gain	$R_L = 10k\Omega$, $V_{out} = 0.5V$ to $2.2V$		126		dB
$V_{CC}-V_{OH}$	High level output voltage drop	$R_L = 600\Omega$, $T = 25^{\circ}C$ TS507C full temp range TS507I full temp range		57	85 100 105	mV
		$R_L = 10k\Omega$, $T = 25^{\circ}C$ Full temp range		4	15 15	
V_{OL}	Low level output voltage	$R_L = 600\Omega$, $T = 25^{\circ}C$ TS507C full temp range TS507I full temp range		57	80 100 115	mV
		$R_L = 10k\Omega$, $T = 25^{\circ}C$ Full temp range		4	15 15	
I_{out}	I_{sink}	$V_{out} = V_{CC}$, $V_{id} = -1V$, $T = 25^{\circ}C$ TS507C full temp range TS507I full temp range	20 15 13	30		mA
	I_{source}	$V_{out} = V_{DD}$, $V_{id} = 1V$, $T = 25^{\circ}C$ TS507C full temp range TS507I full temp range	22 19 17	35		
I_{CC}	Supply current (per operator) ⁽²⁾	No load, $V_{out} = V_{CC}/2$, $V_{icm} = 0$ to $2.7V$, $T = 25^{\circ}C$ Full temp range		0.79	1.1 1.2	mA

Table 5. Electrical characteristics at $V_{CC} = +2.7V$, $V_{DD} = 0V$, $V_{icm} = V_{CC}/2$, $T_{amb} = 25^{\circ}C$, R_L connected to $V_{CC}/2$ (unless otherwise specified)⁽¹⁾ (continued)

Symbol	Parameter	Conditions	Min.	Typ.	Max.	Unit
Dynamic performance						
GBP	Gain bandwidth product	$R_L = 2k\Omega$, $C_L = 100pF$, $f = 100kHz$		1.9		MHz
ϕ_m	Phase margin	$R_L = 2k\Omega$, $C_L = 100pF$		45		Degrees
SR	Slew rate	$R_L = 2k\Omega$, $C_L = 100pF$, $V_{out} = 0.5V$ to $2.2V$, 10% to 90%		0.6		V/ μs
e_N	Equivalent input noise voltage	$f = 1kHz$		12		nV/ \sqrt{Hz}
THD+ e_N	THD + noise	$f = 1KHz$, $G = 1$, $R_L = 2k\Omega$, $V_{icm} = 0.85V$, $V_{out} = 1.2V_{pp}$		0.0005		%

1. All parameter limits at temperatures other than $25^{\circ}C$ are guaranteed by correlation.
2. Measurements done at 4 V_{icm} values: $V_{icm} = 0V$, $V_{icm} = 1.5V$, $V_{icm} = 1.9V$, $V_{icm} = 2.7V$.

Figure 1. Input offset voltage distribution for $V_{icm} \leq V_{CC}-1.2V$ at $T=25^{\circ}C$

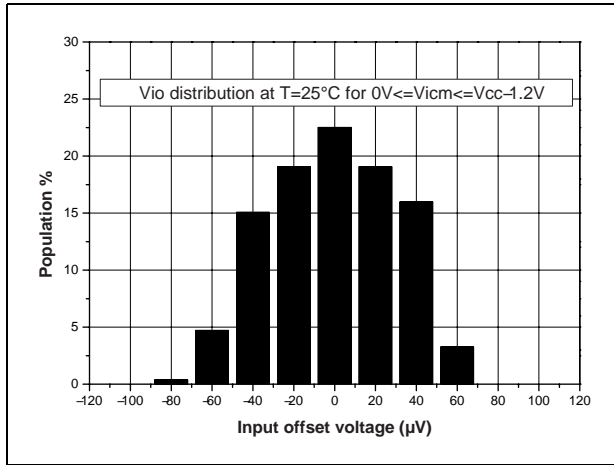

Figure 2. Input offset voltage distribution vs. temperature for $V_{icm} \leq V_{CC}-1.2V$

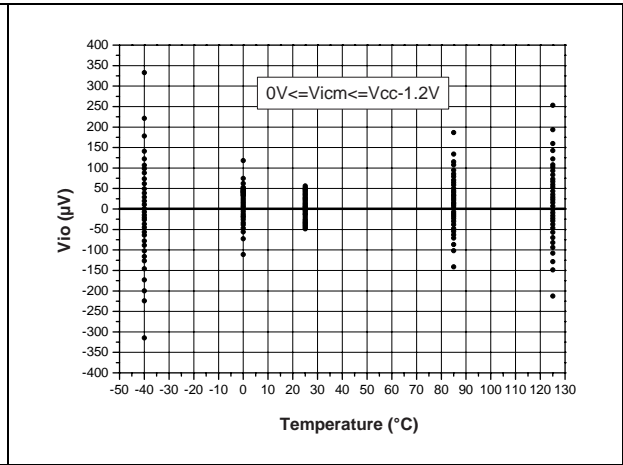

Figure 3. Input offset voltage distribution vs. temperature for $V_{icm} \geq V_{CC}-0.8V$

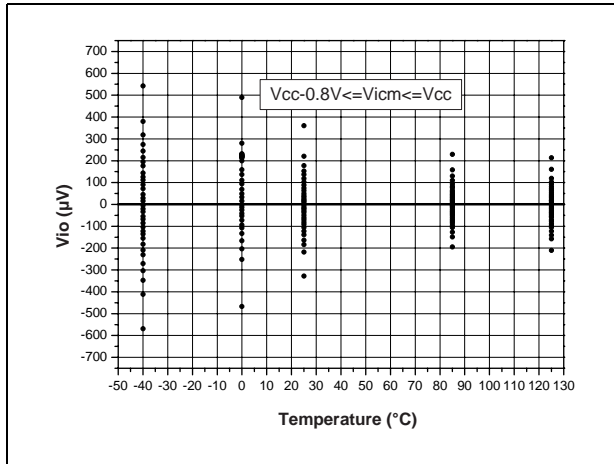

Figure 4. Input offset voltage distribution for $V_{icm} \leq V_{CC}-1.2V$ at $T=25^{\circ}C$ after HTB

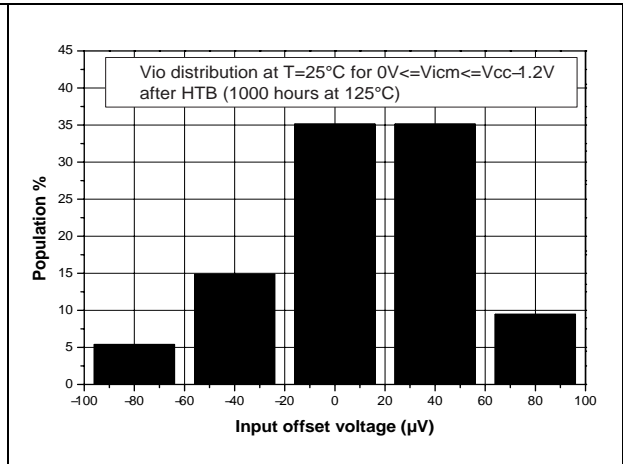

Figure 5. Input offset voltage distribution for $V_{icm} \leq V_{CC}-1.2V$ at $T=25^{\circ}C$ after THB

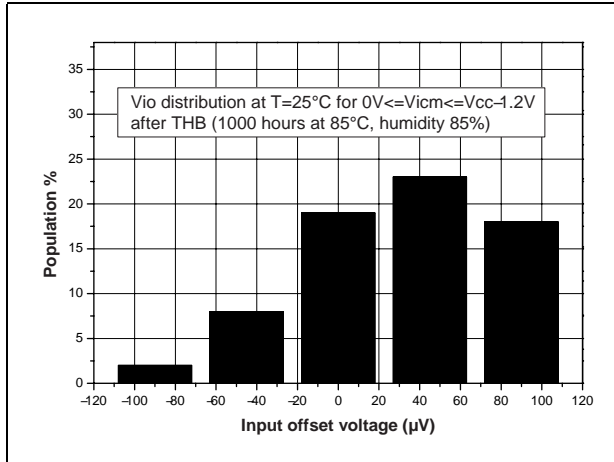

Figure 6. Input offset voltage vs. input common mode voltage at $T=25^{\circ}C$

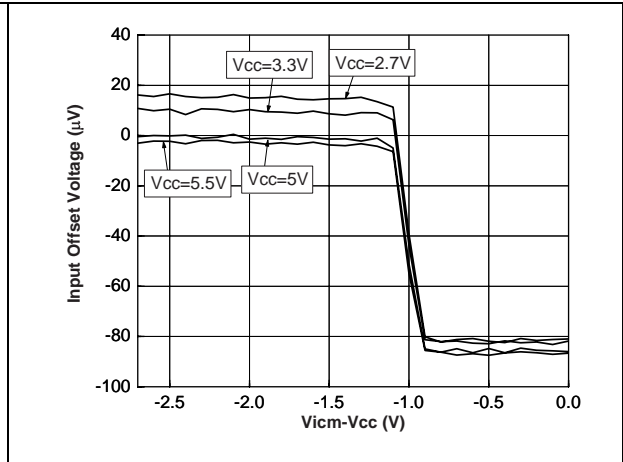

Figure 7. Supply current vs. input common mode voltage in closed loop configuration at $V_{CC}=5V$

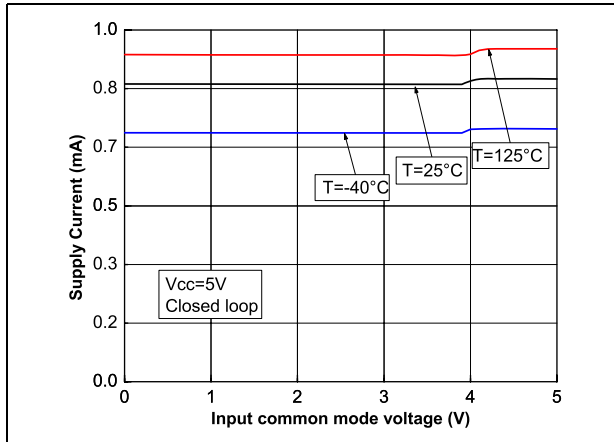

Figure 8. Supply current vs. supply voltage at $V_{icm}=V_{CC}/2$

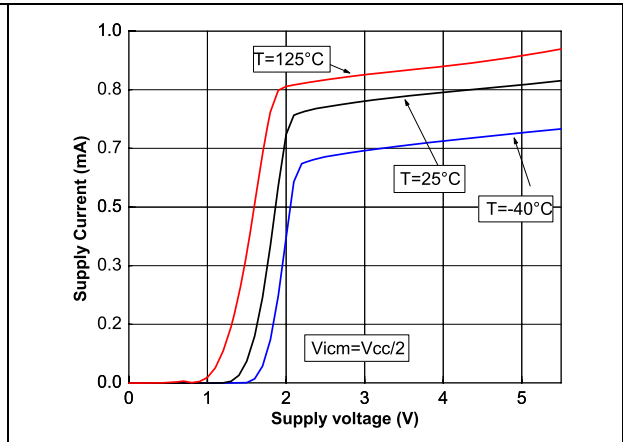

Figure 9. Supply current vs. input common mode voltage in follower configuration at $V_{CC}=2.7V$

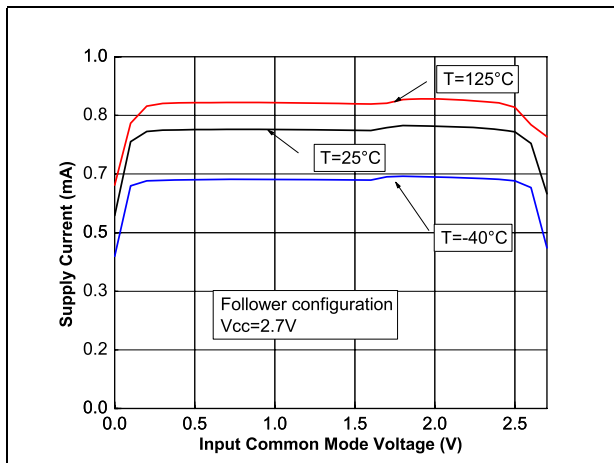

Figure 10. Supply current vs. input common mode voltage in follower configuration at $V_{CC}=5V$

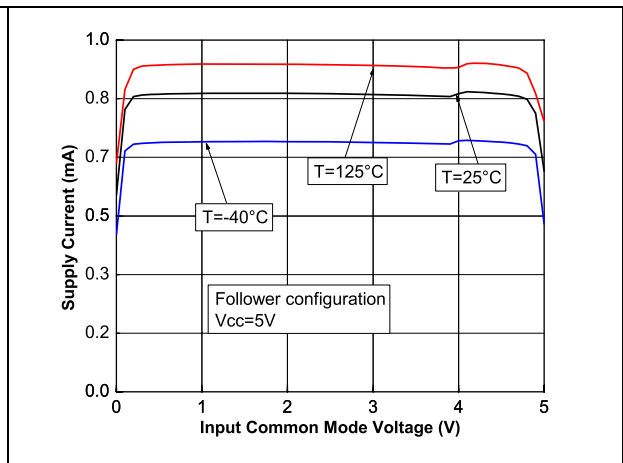

Figure 11. Output current vs. supply voltage at $V_{icm}=V_{CC}/2$

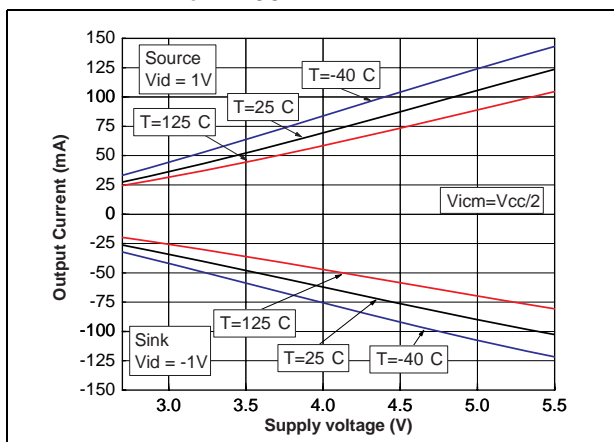

Figure 12. Output current vs. output voltage at $V_{CC}=2.7V$

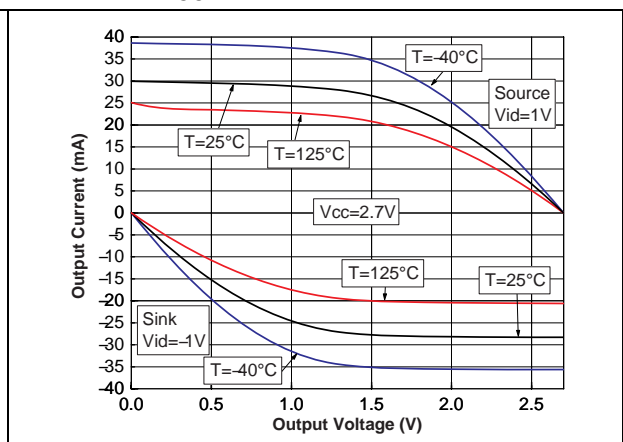

Figure 13. Output current vs. output voltage at $V_{CC}=5V$

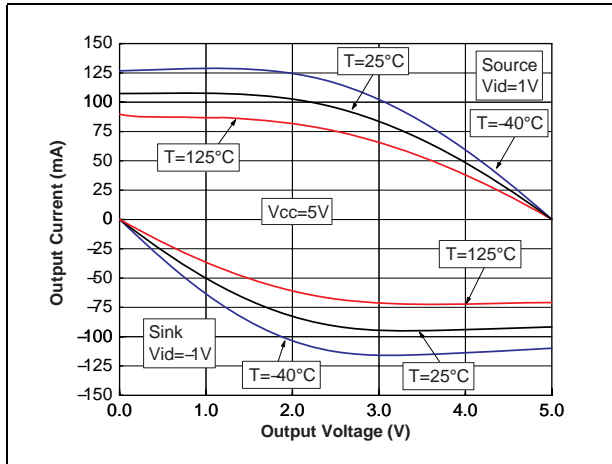

Figure 14. Positive and negative slew rate vs. supply voltage

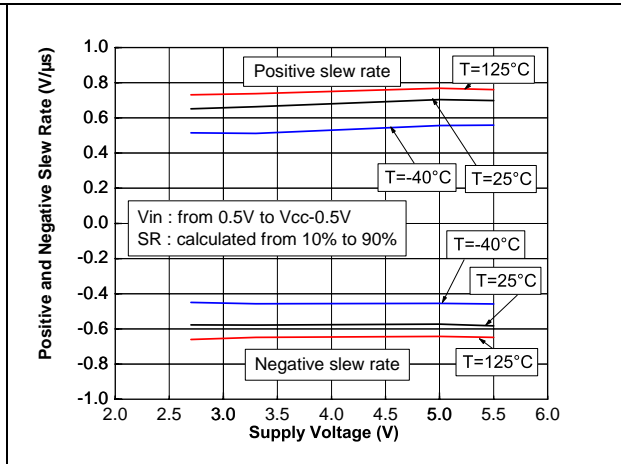

Figure 15. Voltage gain and phase vs. frequency at $V_{CC}=5V$ and $V_{icm}=2.5V$ at $T=25^{\circ}C$

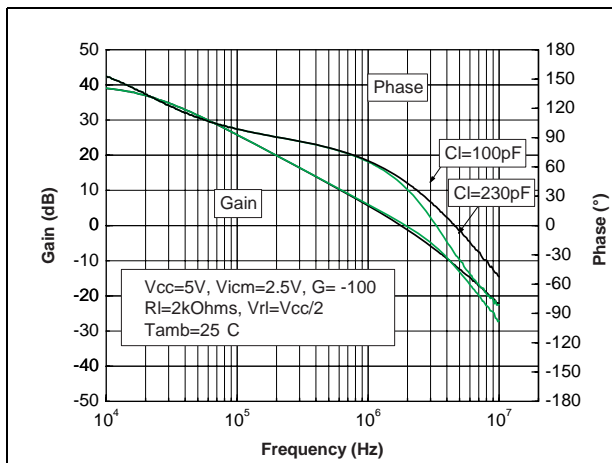

Figure 16. Voltage gain and phase vs. frequency at $V_{CC}=5V$ and $V_{icm}=2.5V$ at $T=-40^{\circ}C$

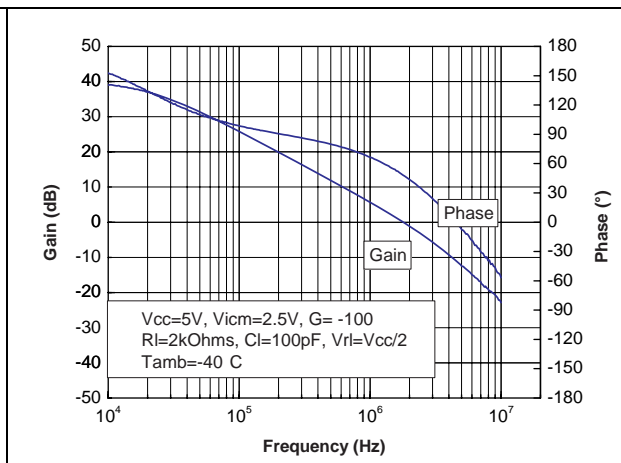

Figure 17. Voltage gain and phase vs. frequency at $V_{CC}=5V$ and $V_{icm}=2.5V$ at $T=125^{\circ}C$

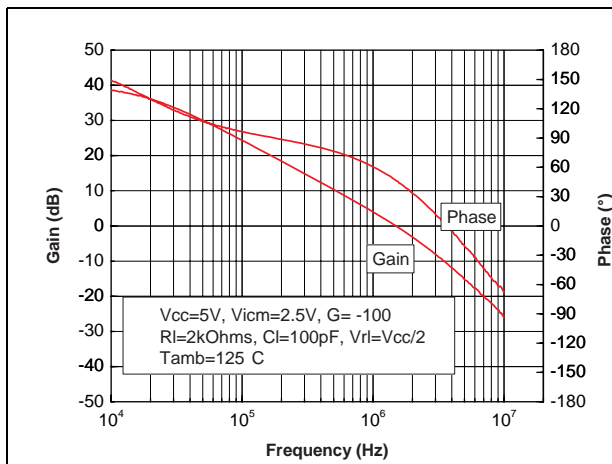

Figure 18. Phase margin vs. capacitive load at $V_{CC}=5V$ and $T=25^{\circ}C$

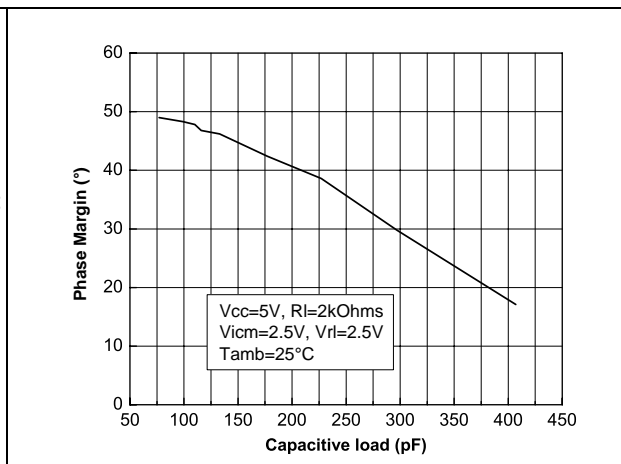

Figure 19. Phase margin vs. output current, at $V_{CC}=5V$ and $T=25^{\circ}C$ **Figure 20. Distortion + noise vs. output voltage**

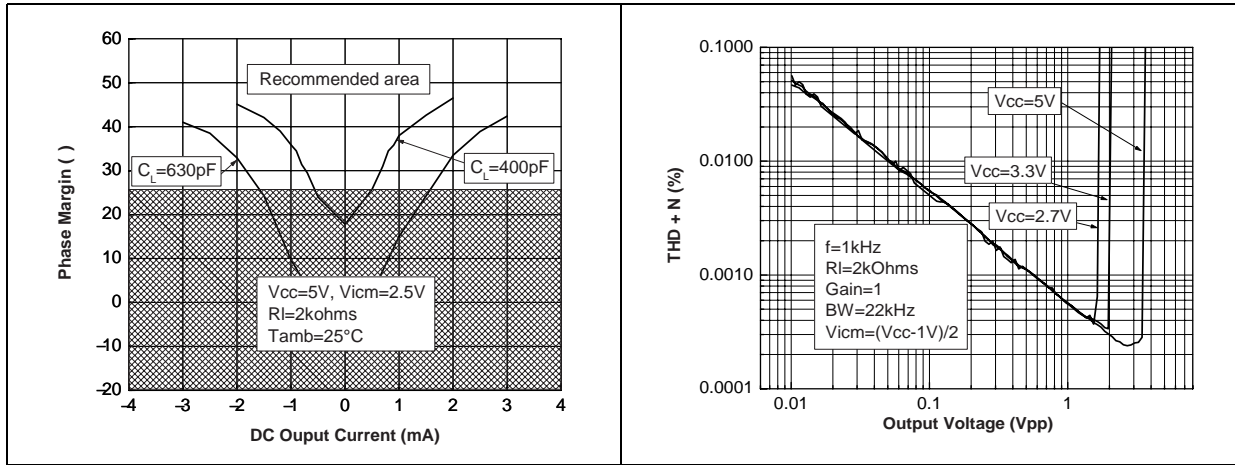

Figure 21. Distortion + noise vs. frequency

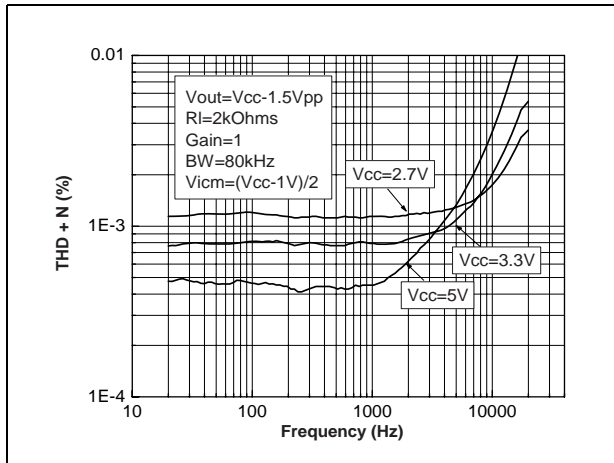

Figure 22. Noise vs. frequency

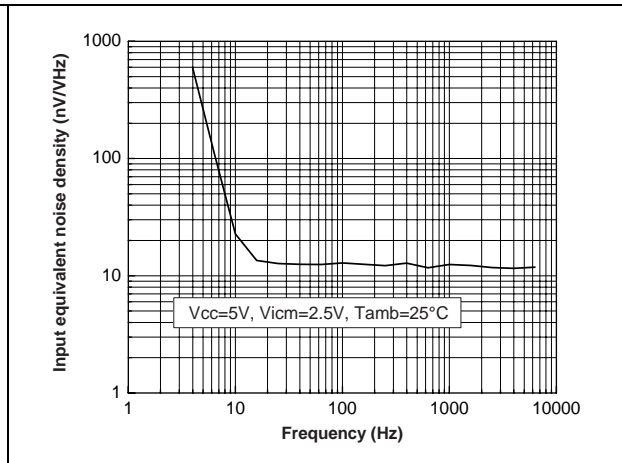
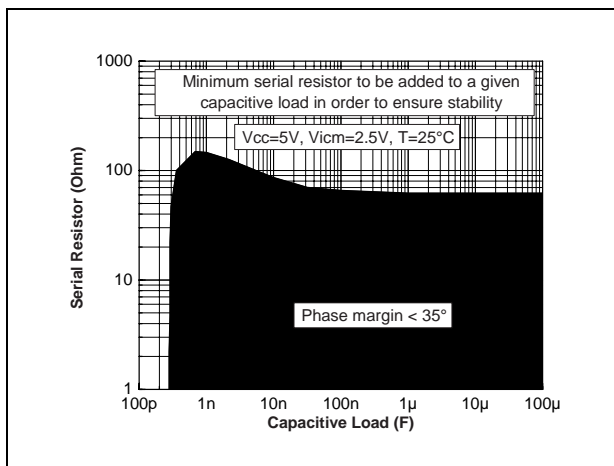

Figure 23. Capacitive loading: serial resistor selector chart



3 Package information

In order to meet environmental requirements, STMicroelectronics offers these devices in ECOPACK[®] packages. These packages have a lead-free second level interconnect. The category of second level interconnect is marked on the package and on the inner box label, in compliance with JEDEC Standard JESD97. The maximum ratings related to soldering conditions are also marked on the inner box label. ECOPACK is an STMicroelectronics trademark. ECOPACK specifications are available at: www.st.com.

3.1 SOT23-5 package mechanical data

Ref.	Dimensions					
	Millimeters			Mils		
	Min.	Typ.	Max.	Min.	Typ.	Max.
A	0.90		1.45	35.4		57.1
A1	0.00		0.15	0.00		5.9
A2	0.90		1.30	35.4		51.2
b	0.35		0.50	13.7		19.7
C	0.09		0.20	3.5		7.8
D	2.80		3.00	110.2		118.1
E	2.60		3.00	102.3		118.1
E1	1.50		1.75	59.0		68.8
e		0.95			37.4	
e1		1.9			74.8	
L	0.35		0.55	13.7		21.6

3.2 SO-8 package mechanical data

Ref.	Dimensions					
	Millimeters			Inches		
	Min.	Typ.	Max.	Min.	Typ.	Max.
A	1.35		1.75	0.053		0.069
A1	0.10		0.25	0.04		0.010
A2	1.10		1.65	0.043		0.065
B	0.33		0.51	0.013		0.020
C	0.19		0.25	0.007		0.010
D	4.80		5.00	0.189		0.197
E	3.80		4.00	0.150		0.157
e		1.27			0.050	
H	5.80		6.20	0.228		0.244
h	0.25		0.50	0.010		0.020
L	0.40		1.27	0.016		0.050
k	8° (max.)					
ddd			0.1			0.04

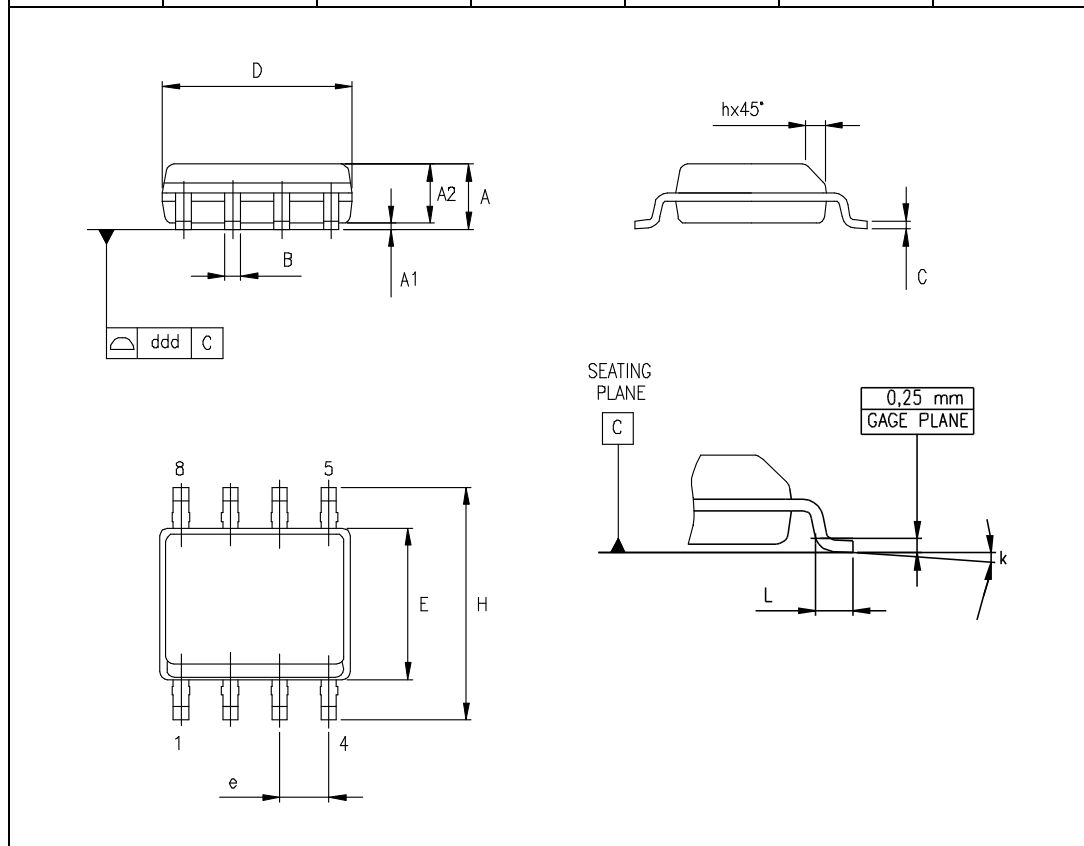

4 Ordering information

Table 6. Order codes

Part number	Temperature range	Package	Packing	Marking
TS507ID-TS507IDT	-40°C to 125°C	SO-8	Tube or tape & reel	TS507I
TS507IYD-TS507IYDT ⁽¹⁾	-40°C to 125°C	SO-8 (Automotive grade)		507IY
TS507ILT	-40°C to 125°C	SOT23-5 ⁽²⁾	Tape & reel	K131
TS507IYLT ⁽¹⁾	-40°C to 125°C	SOT23-5 ⁽²⁾ (Automotive grade)		K137
TS507CD-TS507CDT	0°C to 85°C	SO-8	Tube or tape & reel	TS507C
TS507CLT		SOT23-5 ⁽²⁾	Tape & reel	K136

1. Qualified and characterized according to AEC Q100 and Q003 or equivalent, advanced screening according to AEC Q001 & Q 002 or equivalent.
2. All information related to the SOT23-5 package is subject to change without notice.

5 Revision history

Date	Revision	Changes
1-Oct-2004	1	Preliminary data release for product in development.
2-May-2006	2	Update preliminary data release for product in development.
15-Dec-2006	3	First public release.
3-May-2007	4	Automotive grade part numbers added to Table 6: Order codes . Table 6: Order codes moved to end of document.

Please Read Carefully:

Information in this document is provided solely in connection with ST products. STMicroelectronics NV and its subsidiaries ("ST") reserve the right to make changes, corrections, modifications or improvements, to this document, and the products and services described herein at any time, without notice.

All ST products are sold pursuant to ST's terms and conditions of sale.

Purchasers are solely responsible for the choice, selection and use of the ST products and services described herein, and ST assumes no liability whatsoever relating to the choice, selection or use of the ST products and services described herein.

No license, express or implied, by estoppel or otherwise, to any intellectual property rights is granted under this document. If any part of this document refers to any third party products or services it shall not be deemed a license grant by ST for the use of such third party products or services, or any intellectual property contained therein or considered as a warranty covering the use in any manner whatsoever of such third party products or services or any intellectual property contained therein.

UNLESS OTHERWISE SET FORTH IN ST'S TERMS AND CONDITIONS OF SALE ST DISCLAIMS ANY EXPRESS OR IMPLIED WARRANTY WITH RESPECT TO THE USE AND/OR SALE OF ST PRODUCTS INCLUDING WITHOUT LIMITATION IMPLIED WARRANTIES OF MERCHANTABILITY, FITNESS FOR A PARTICULAR PURPOSE (AND THEIR EQUIVALENTS UNDER THE LAWS OF ANY JURISDICTION), OR INFRINGEMENT OF ANY PATENT, COPYRIGHT OR OTHER INTELLECTUAL PROPERTY RIGHT.

UNLESS EXPRESSLY APPROVED IN WRITING BY AN AUTHORIZED ST REPRESENTATIVE, ST PRODUCTS ARE NOT RECOMMENDED, AUTHORIZED OR WARRANTED FOR USE IN MILITARY, AIR CRAFT, SPACE, LIFE SAVING, OR LIFE SUSTAINING APPLICATIONS, NOR IN PRODUCTS OR SYSTEMS WHERE FAILURE OR MALFUNCTION MAY RESULT IN PERSONAL INJURY, DEATH, OR SEVERE PROPERTY OR ENVIRONMENTAL DAMAGE. ST PRODUCTS WHICH ARE NOT SPECIFIED AS "AUTOMOTIVE GRADE" MAY ONLY BE USED IN AUTOMOTIVE APPLICATIONS AT USER'S OWN RISK.

Resale of ST products with provisions different from the statements and/or technical features set forth in this document shall immediately void any warranty granted by ST for the ST product or service described herein and shall not create or extend in any manner whatsoever, any liability of ST.

ST and the ST logo are trademarks or registered trademarks of ST in various countries.

Information in this document supersedes and replaces all information previously supplied.

The ST logo is a registered trademark of STMicroelectronics. All other names are the property of their respective owners.

© 2007 STMicroelectronics - All rights reserved

STMicroelectronics group of companies

Australia - Belgium - Brazil - Canada - China - Czech Republic - Finland - France - Germany - Hong Kong - India - Israel - Italy - Japan - Malaysia - Malta - Morocco - Singapore - Spain - Sweden - Switzerland - United Kingdom - United States of America

www.st.com