

## Description

Distribution rail with modules connected in series. One module provides 4 positions for magnetic or magnetic-hydraulic circuit breakers type 8340-F... and the pertinent line and load terminals on the front and rear side of the rail. Supply feed is either on the right or left side with copper busbars. Trip indication of the circuit breakers (group signalisation) is possible via two signal busbars. Live parts in the plug-in area of the load terminals are protected against brush contact. Circuit breaker replacement is possible with power on.

## Typical applications

Telecommunications, measuring and control systems

## Ordering information

### Type No.

**X8340** Distribution rail for circuit breaker type 8340-F

### Version

**S** rail

### Identification number

**Z4** module accommodating 4 circuit breakers (smallest unit)

### Terminal (supply feed)

**L** left side

**R** right side

### Power distribution modules

**1** 1 module

**2** 2 modules

**3** 3 modules

**4** 4 modules

**5** 5 modules

### Signalisation

**0** without

**1** group signalisation

### Accessories / variations

**00** none

**01** mounting screw M4 / module bulk shipped

**A1** terminals twisted by 180°

### Additional configuration

**00** neutral

**01** customer specified marking

**X8340 - S Z4 R 3 - 1 00 - 00** ordering example

## Approvals

Authority	Voltage ratings	Current ratings
UL 1059	AC 250 V; DC 80 V	150 A



**X8340-SZ4**

## Technical data

Plug-in type circuit breakers	8340-F110-P1...-H...	
Voltage rating	AC 230 V; DC 80 V	
Load	25 A per position (30 A upon request) 150 A for the rail	
Signalisation (N/C contact)	6 A, AC 230 V 1 A, DC 80 V per position	
Insulation co-ordination (IEC 60664)	Rated impulse withstand voltage 2.5 kV	Pollution degree 2
Flame retardance (IEC 60695, part 2-2)	self-extinguishing	
Terminal design supply feed	copper busbar 10x3 mm with hole ø 5.3 mm dia. current supply from the rear side (left or right)	
loads	blade terminals DIN 46244-A6.3x0.8mm load output terminal protected against reverse polarity on front and rear side	
signalisation	blade terminals DIN 46244-A6.3x0.8mm plug-in direction as circuit breakers, opposite to the main terminal side	
Mass		
module	200 g	
every additional module	145 g	

**Dimensions**

**Distribution rail. Power supply left-side**

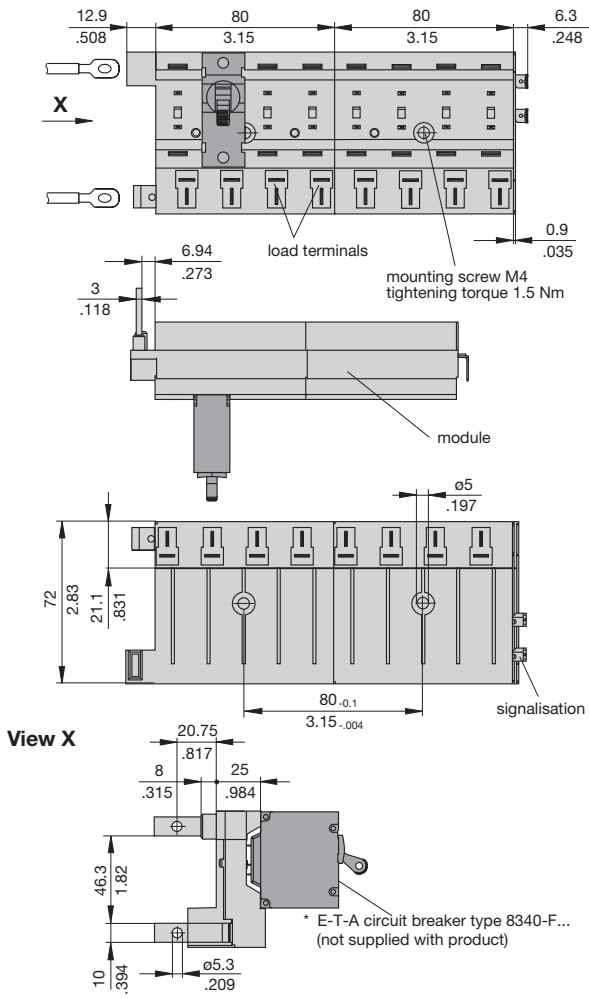

**Distribution rail. Power supply right-side**

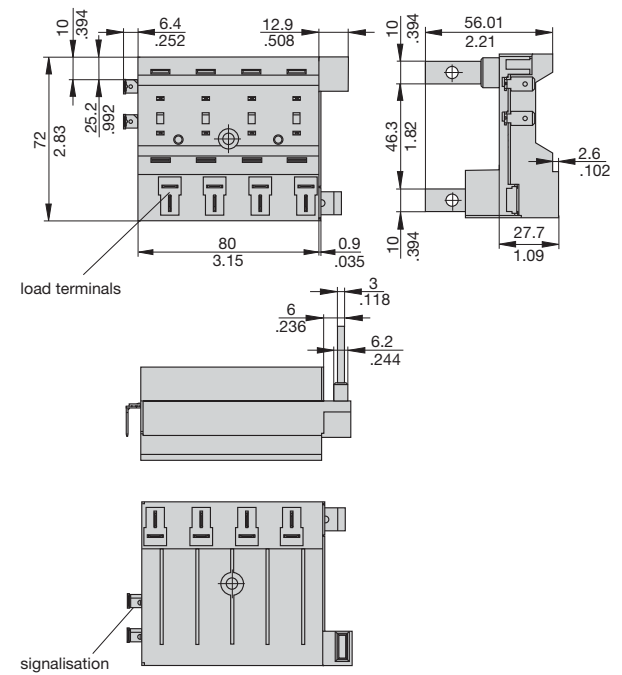

**Distribution rail X8340-SZ4L1-0A1**

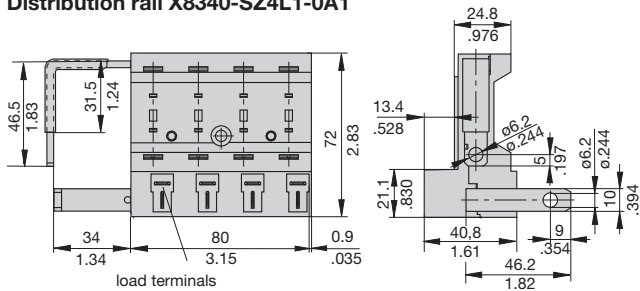

## Internal connection diagram

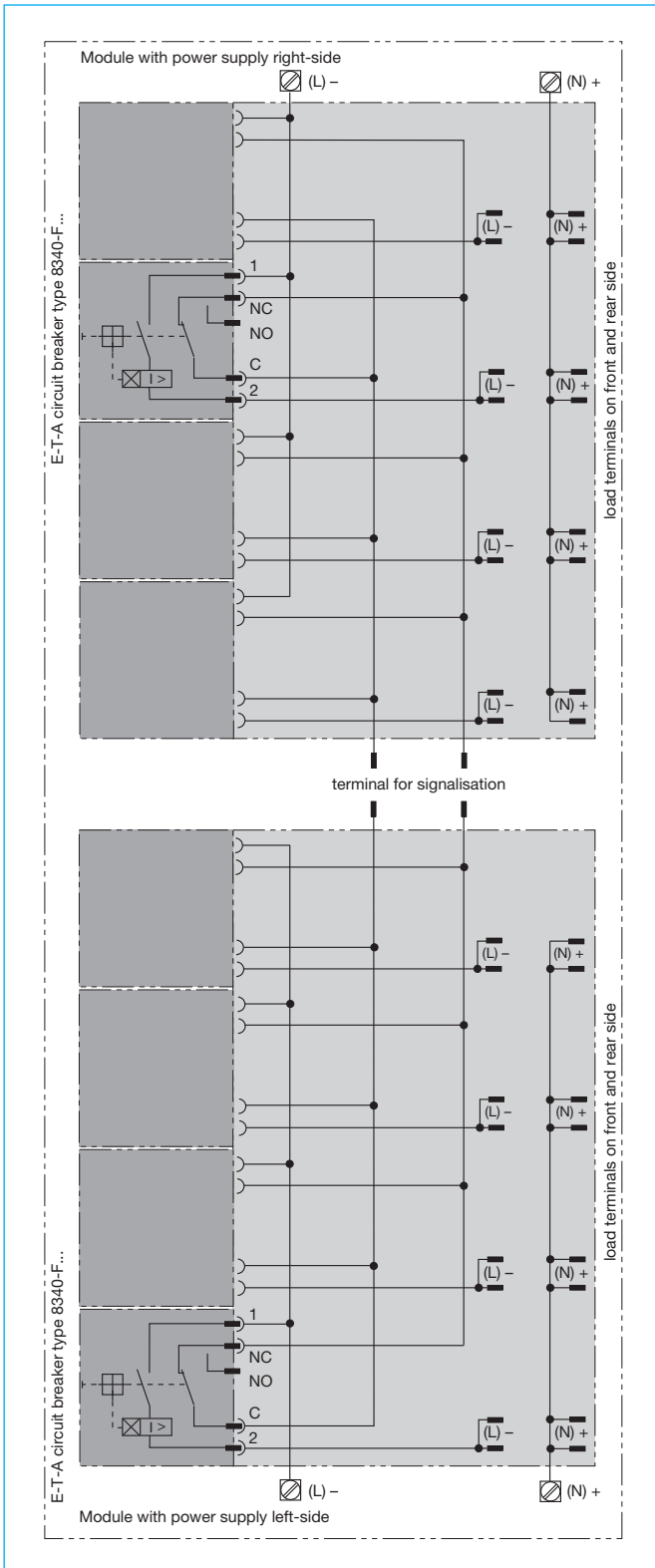

## Internal connection diagrams

**Load output terminal protected against reverse polarity**  
 (set: 4 moulded sleeves, 8 blade terminals 6.3 x 0.8 mm)  
**X 222 847 01** for cable cross section 0.7...2.0 mm<sup>2</sup>  
**X 222 625 01** for cable cross section 2.5...4.0 mm<sup>2</sup>  
**X 222 848 01** for cable cross section 4.0...6.0 mm<sup>2</sup>

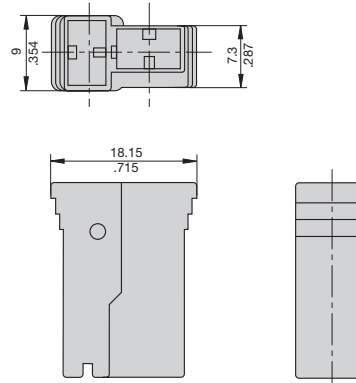

This is a metric design and millimeter dimensions take precedence ( $\frac{\text{mm}}{\text{inch}}$ )

All dimensions without tolerances are for reference only. In the interest of improved design, performance and cost effectiveness the right to make changes in these specifications without notice is reserved. Product markings may not be exactly as the ordering codes. Errors and omissions excepted.