

LOW EMI CURRENT SENSE HIGH SIDE SWITCH

Features

- Load current feedback
- Programmable over current shutdown
- Active clamp
- ESD protection
- Input referenced to Vcc
- Over temperature shutdown
- Switching time optimized for low EMI
- Reverse battery protection

Description

The IR3316SPbF is a fully protected 4 terminals high side switch. The input signal is referenced to Vcc. When the input voltage Vcc - Vin is higher than the specified threshold, the output power Mosfet is turned on. When the Vcc - Vin is lower than the specified Vil threshold, the output Mosfet is turned off. A current proportional to the power Mosfet current is sourced to the Ifb pin. Over current shutdown occurs when Vst-Vin > 4.5V. The current shutdown threshold is adjusted by selecting the proper Rlfb. Either over current and over temperature latches off the switch. The device is reset by pulling the input pin high. Other integrated protections (ESD, reverse battery, active clamp) make the switch very rugged in automotive environment.

Typical Connection

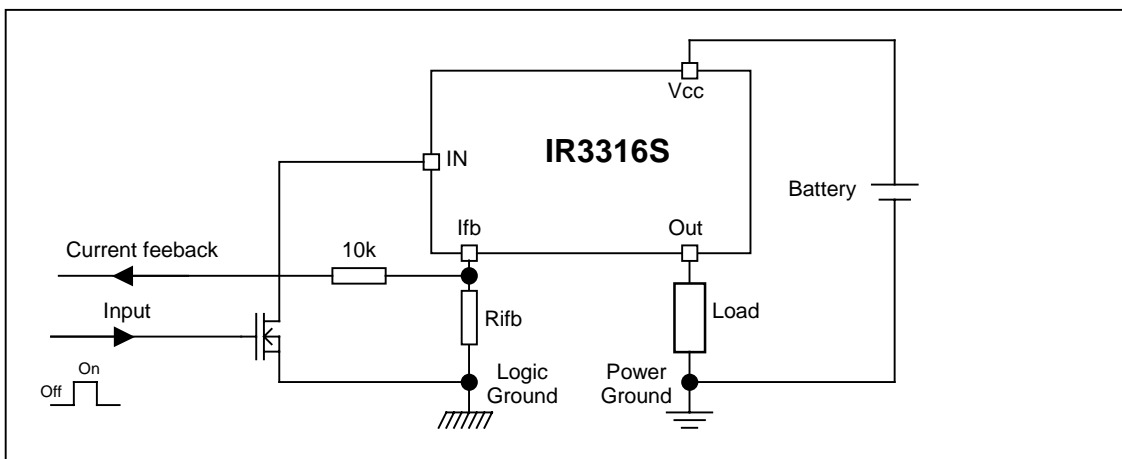

Product Summary

Rds(on)	7 mΩ max.
Vcc op.	6 to 26V
Current Ratio	8800
Prog. Ishutdown	10 to 90A
Vclamp	40V

Packages



D²Pak
Pin 4 and 5 fused
IR3316SPbF

Absolute Maximum Ratings

Absolute maximum ratings indicate sustained limits beyond which damage to the device may occur. All voltage parameters are referenced to Vcc lead. (Tambient=25°C unless otherwise specified).

Symbol	Parameter	Min.	Max.	Units
Vcc-Vin	Maximum Vcc voltage	-16	37	V
Vcc-Vin cont.	Maximum continuous Vcc voltage	-16	26	
Vcc-Vfb	Maximum lfb voltage	-16	33	
Vcc-Vout	Maximum output voltage	-0.3	37	
I _{ds} cont.	Maximum body diode continuous current R _{th} =60°C/W (1)	—	2.8	A
I _{ds} pulsed	Maximum body diode pulsed current (1)	—	100	
P _d	Maximum power dissipation R _{th} =60°C/W	—	2	W
ESD1	Electrostatic discharge voltage (Human body) C=100pF, R=1500Ω	—	4	kV
ESD2	Electrostatic discharge voltage (Machine Model) C=200pF, R=0Ω	—	0.5	
T _j max.	Max. storage & operating temperature junction temperature	-40	150	°C
Min Rfb	Minimum on the resistor on lfb pin	0.3	—	kΩ
I _{fb} max.	Max. lfb current	-50	50	mA

(1) Limited by junction temperature. Pulsed is also limited by wiring

Thermal Characteristics

Symbol	Parameter	Typ.	Max.	Units
Rth1	Thermal resistance junction to ambient D ² -Pak Std footprint	60	—	°C/W
Rth2	Thermal resistance junction to case D ² -Pak	0.7	—	

Recommended Operating Conditions

These values are given for a quick design. For operation outside these conditions, please consult the application notes.

Symbol	Parameter	Min.	Max.	Units
I _{out}	Continuous output current T _{ambient} =85°C, R _{th} =60°C/W, T _j =125°C	—	7	A
R _{lfb}	Recommended lfb resistor (2)(3)	0.5	3.5	kΩ
Pulse min.	Minimum turn-on pulse width	1	—	ms
F _{max}	Maximum operating frequency	—	200	Hz

2) If R_{lfb} is too low, the device can be damaged.

3) If R_{lfb} is too high, the device may not switch on.

Protection Characteristics

T_j=25°C, R_{ifb}=500 to 5kΩ

Symbol	Parameter	Min.	Typ.	Max.	Units	Test Conditions
V _{ifb-Vin@Isd}	Over-current shutdown threshold	4	4.7	5.6	V	
T _{sd}	Over temperature threshold	—	165	—	°C	See fig. 5
OV	Over voltage protection (not latched)	26	29	33	V	
Isdf	Fixed over current shutdown	90	120	140	A	V _{ifb} <V _{ifb-Vin@Isd} R _{ifb} =1kΩ
Isd_1k	Programmable over current shutdown 1k	30	40	50		
T _{reset}	Time to reset protection	—	50	500	μs	See fig. 5
Min. pulse	Min. pulse width (no WAIT state)	400	900	2000		
WAIT	WAIT function timer	0.4	1	2	ms	See fig. 4 and 5
R _{ds(on) rev.}	Reverse battery On state resistance	4	6.7	10	mΩ	V _{cc-Vin} =-14V, I _{out} =30A

Static Electrical Characteristics

T_j=25°C, V_{cc}=14V (unless otherwise specified)

Symbol	Parameter	Min.	Typ.	Max.	Units	Test Conditions
V _{cc op.}	Operating Voltage range	6	—	26	V	
I _{cc off}	Supply leakage current	—	1.5	5	μA	V _{in} =V _{cc} , V _{cc-Vout} =14V, V _{cc-Vifb} =14V
I _{in, on}	On state I _N positive current	1.5	3	6	mA	V _{cc-Vin} =14V
V _{ih}	High level Input threshold voltage (4)	—	5.4	6.2	V	
V _{il}	Low level Input threshold voltage (4)	4	4.9	5.8		
V _{hyst}	Input hysteresis V _{ih} -V _{il}	0.2	0.4	1		
I _{out}	Drain to source leakage current	—	1.2	5	μA	V _{in} =V _{cc} , V _{cc-Vifb} =0V, V _{cc-Vout} =14V
R _{ds(on)}	On state resistance (5) T _j =25°C	4	5.5	7	mΩ	I _{out} =30A, V _{cc-Vin} =14V
	On state resistance (5) T _j =25°C	4	6	10		I _{out} =17A, V _{cc-Vin} =6V
	On state resistance (5) T _j =150°C	7	10.5	13.5		I _{out} =30A, V _{cc-Vin} =14V
V _{clamp1}	V _{cc} to V _{out} clamp voltage 1	36	39	—	V	I _{out} =50mA
V _{clamp2}	V _{cc} to V _{out} clamp voltage 2	—	40	43		I _{out} =30A

(4) Input thresholds are measured directly between the input pin and the tab. Any parasitic resistance in common between the load current path and the input signal path can significantly affect the thresholds.

(5) R_{ds(on)} is measured between the tab and the Out pin, 5mm away from the package.

Switching Electrical Characteristics

V_{cc}=14V, Resistive load=0.5Ω, T_j=25°C

Symbol	Parameter	Min.	Typ.	Max.	Units	Test Conditions
T _{don}	Turn on delay time to 10% V _{cc}	30	120	300	μs	See figure 2
Tr1	Rise time to V _{cc-Vout} =5V	20	50	125		
Tr2	Rise time to V _{cc-Vout} =0.1V _{cc}	30	80	200		
E _{on}	Turn on energy	—	14	—	mJ	
T _{doff}	Turn off delay time	30	140	350	μs	
T _f	Fall time to V _{out} =10% of V _{cc}	35	100	250		
E _{off}	Turn off energy	—	7	—	mJ	

Current Sense Characteristics

Symbol	Parameter	Min.	Typ.	Max.	Units	Test Conditions
Ratio	I Load/I _{fb} current ratio	7,500	8,800	9,950	—	T _j =25°C, R _{fb} =500Ω, I _{out} =60A
Ratio_TC	I Load/I _{fb} variation aver temperature	-5	—	+5	%	T _j =-40°C to 150°C
Offset	Load current diagnostic offset	-0.22	0	+0.2	A	I _{out} =2A
Trst	I _{fb} response time (low signal)	—	1	—	μs	90% of the I _{out} step

Functional Block Diagram

All values are typical

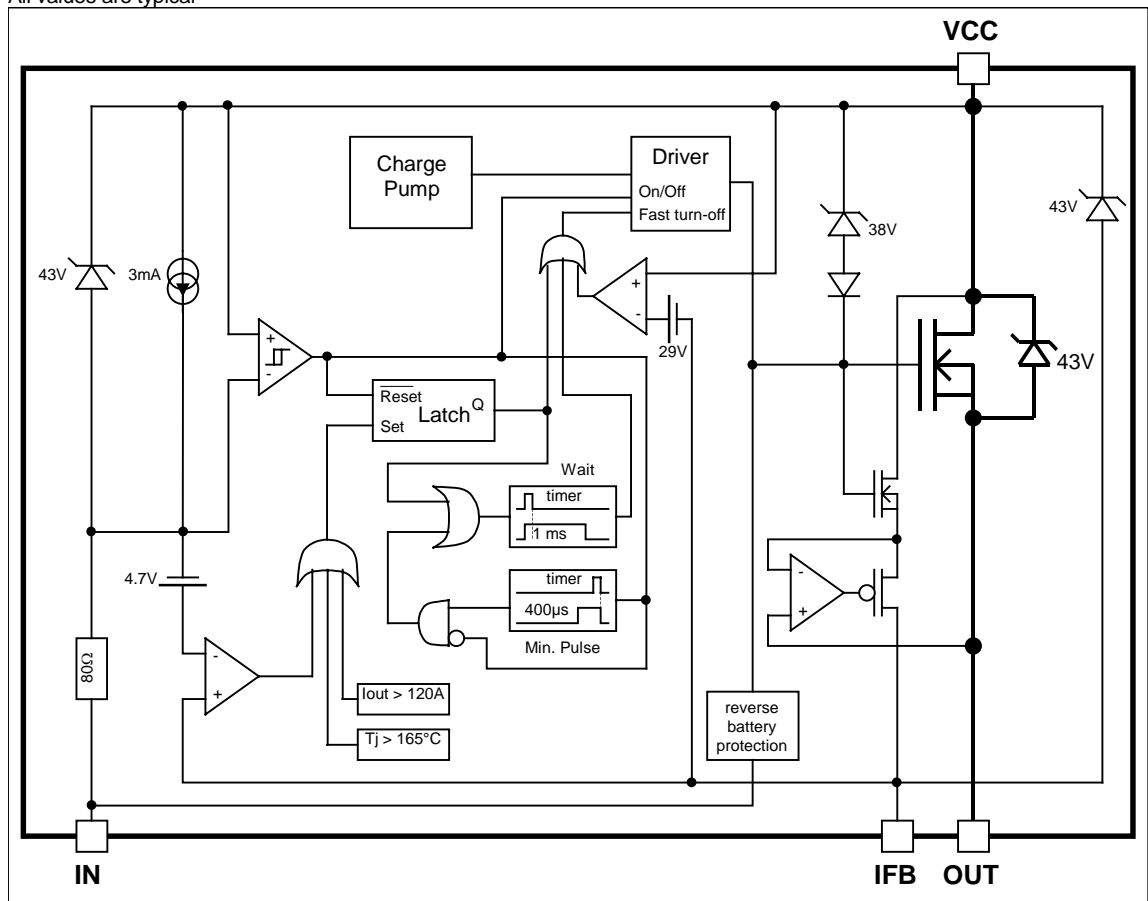

Lead Assignments

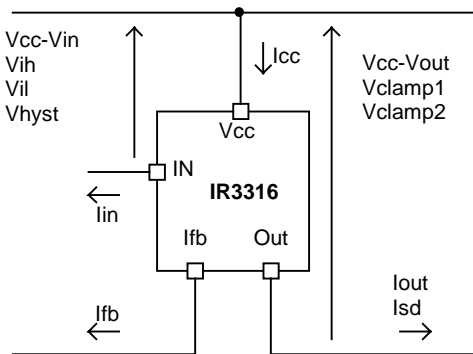
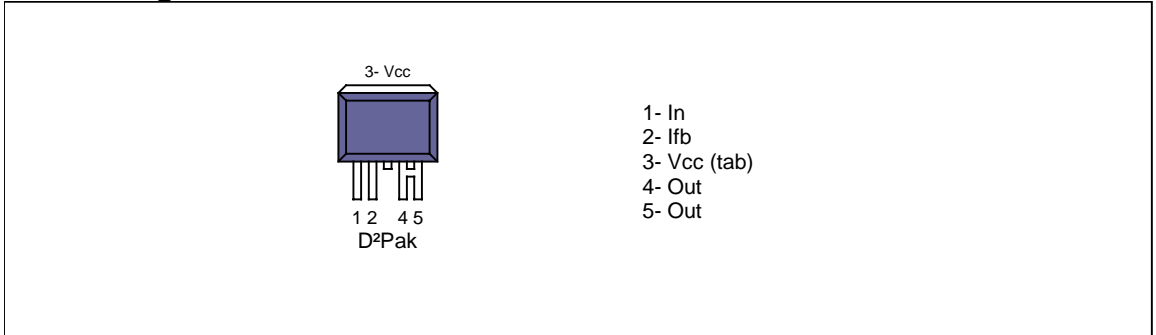

Figure 1 – Voltages and current definitions

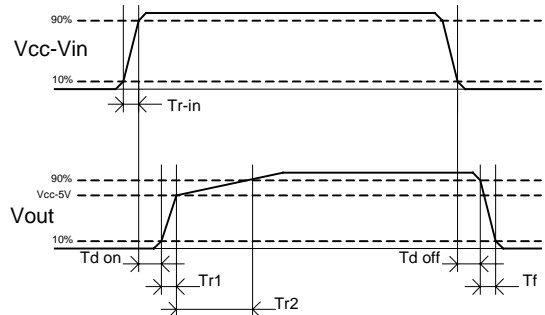

Figure 2 – Switching time definitions

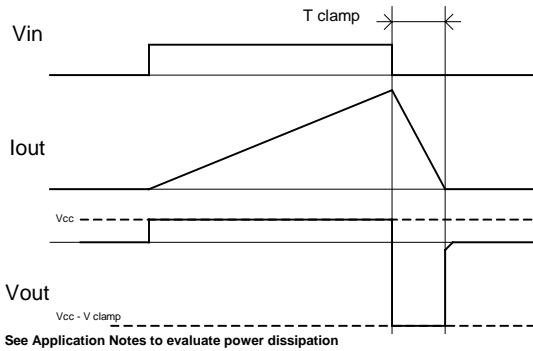

Figure 3 – Active clamp waveforms

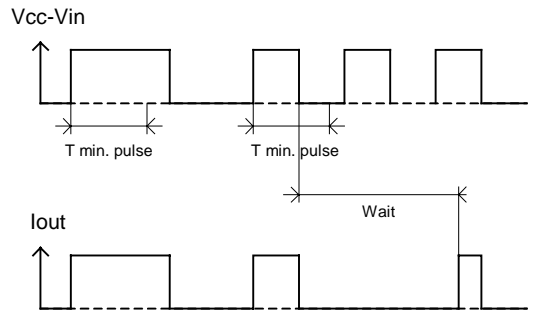

Figure 4 – Min. pulse and Wait function

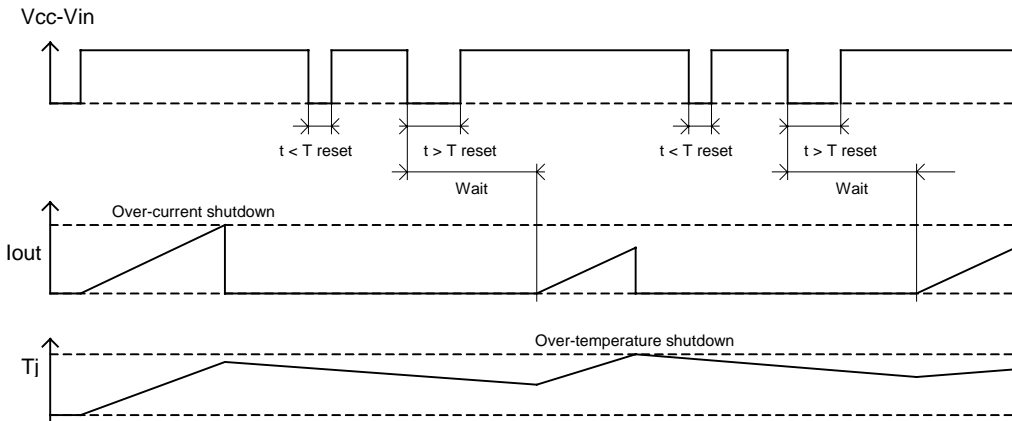

Figure 5 – Protection Timing Diagrams

All curves are typical characteristics. Operation in hatched areas is not recommended. $T_j=25^\circ\text{C}$, $R_{\text{th}}=500\text{ohm}$, $V_{\text{cc}}=14\text{V}$ (unless otherwise specified).

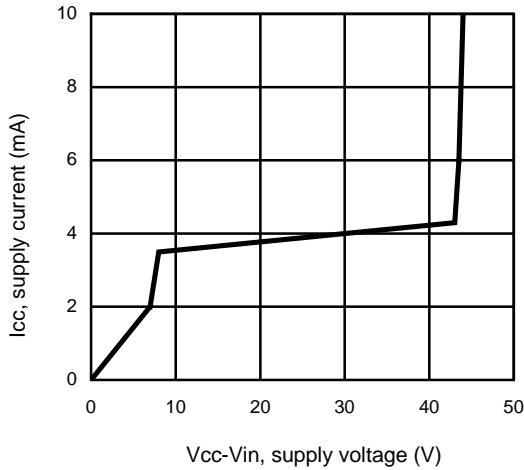

Figure 6 – I_{cc} (mA) Vs $V_{\text{cc}}-V_{\text{in}}$ (V)

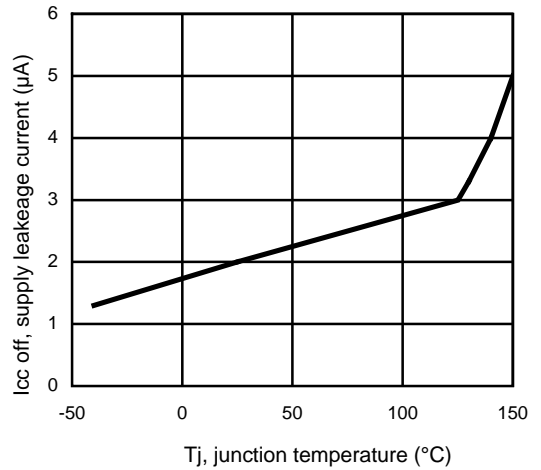

Figure 7 – $I_{\text{cc off}}$ (μA) Vs T_j ($^\circ\text{C}$)

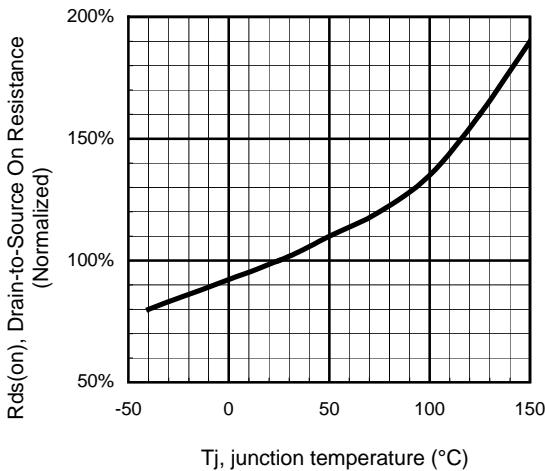

Figure 8 - Normalized $R_{\text{ds(on)}}$ (%) Vs T_j ($^\circ\text{C}$)

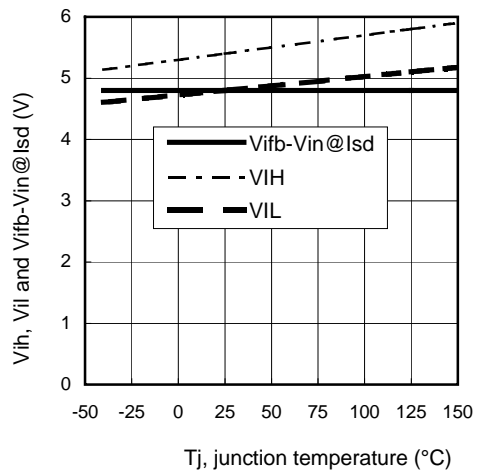

Figure 9 – V_{IH} , V_{IL} and $V_{\text{f(b)}}-V_{\text{in@I(s,d)}}$ (V) Vs T_j ($^\circ\text{C}$)

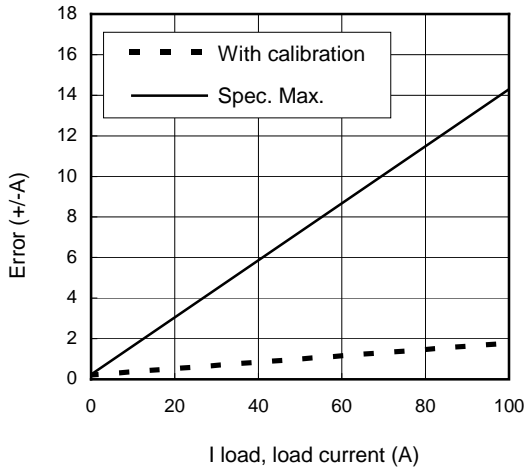

Figure 10 – Error (+/- A) Vs I load (A)

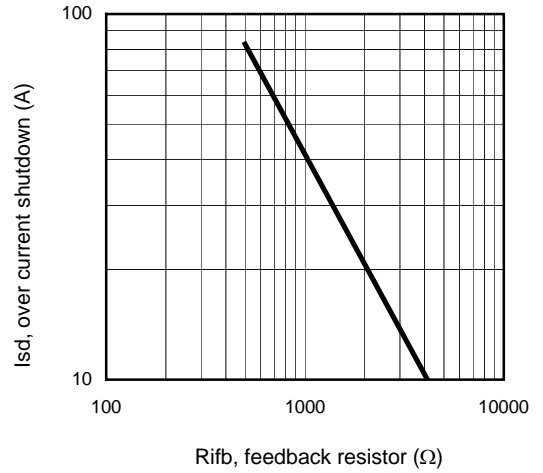

Figure 11 – Ids (A) Vs Rifb (Ω)

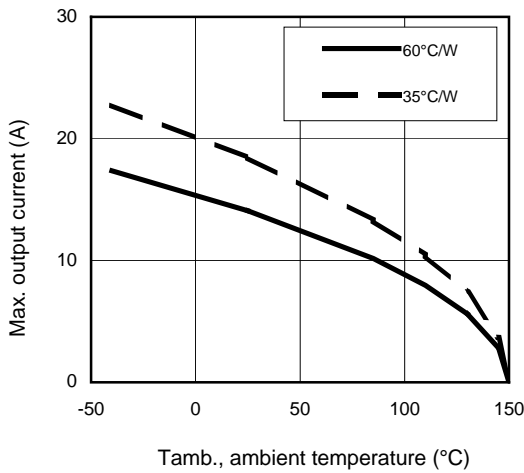

Figure 12 – Max. iout (A) Vs Tamb. (°C)

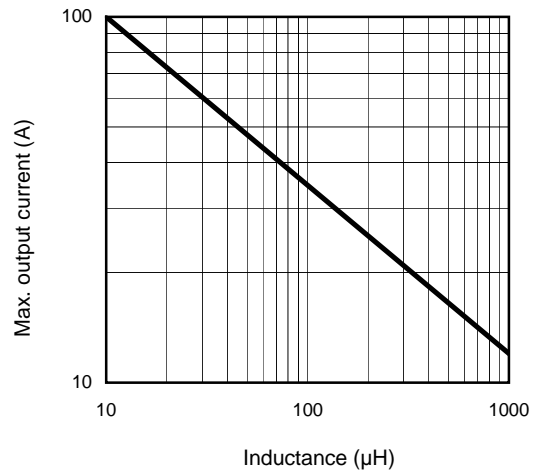

Figure 13 – Max. iout (A) Vs inductance (μH)

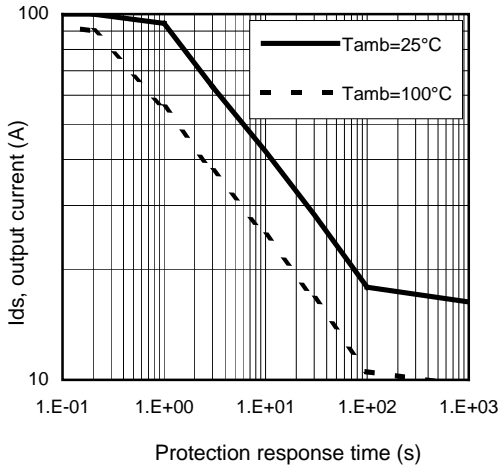

Figure 14 – Ids (A) Vs over temperature protection response time (s)

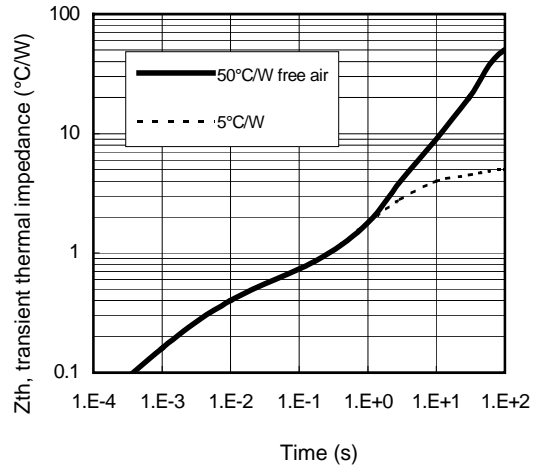
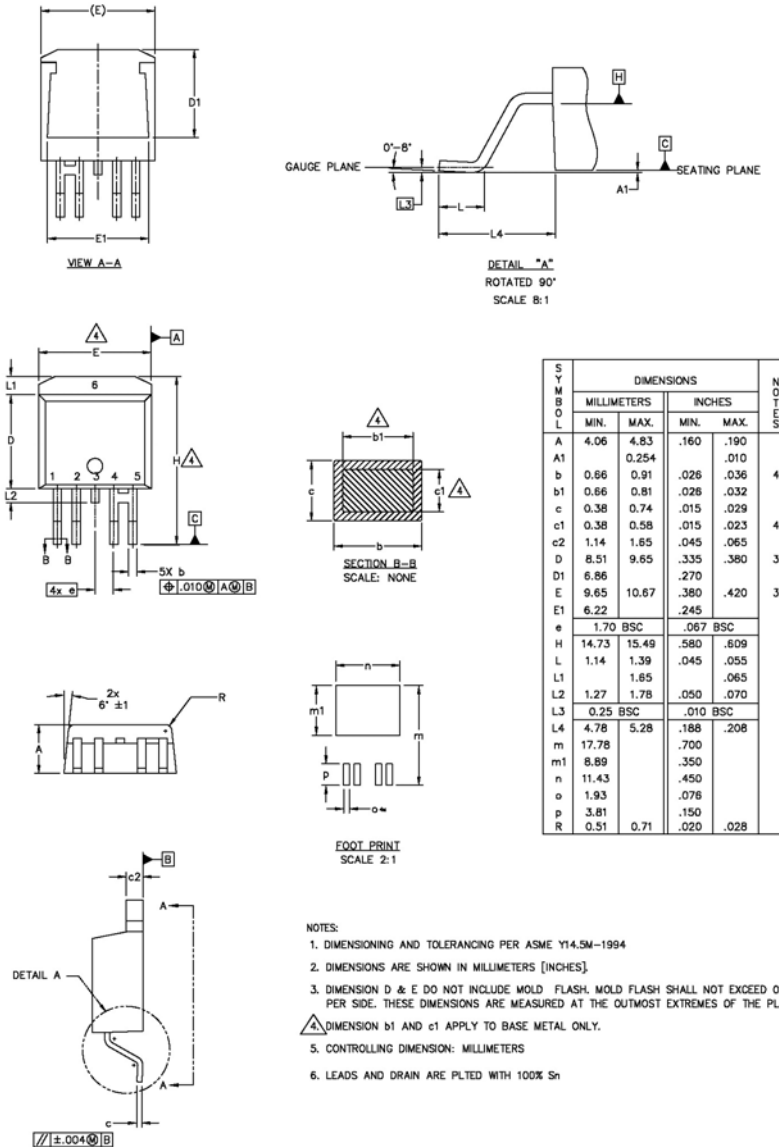

Figure 15 – Transient thermal impedance (°C/W) Vs time (s)

Case Outline 5 Lead - D2PAK



Note: For the most current drawings please refer to the IR website at:
<http://www.irf.com/package/>