

# Modular Switching Power Supply Type SPM 5 DIN rail mounting

CARLO GAVAZZI



- Single DIN module
- Universal input 90/264VAC – 120/370VDC
- High efficiency up to 89%
- Short circuit protection
- Overload protection
- Internal input filter
- LOW voltage LED indicator
- UL Class 2 Output (only 91W version)

## Product Description

SPM Modular switching power supplies are specifically designed in order to satisfy both the Automation and the Building automation application requirements. The five DIN modules PS is capable of up to 10W of output power. Its high efficiency prevents excess of heat in the installation place.

## Ordering Key

**SPM 5 - 24 1**

Series \_\_\_\_\_  
 Number of DIN modules \_\_\_\_\_  
 Output Voltage \_\_\_\_\_  
 Phases (only single phase) \_\_\_\_\_

## Approvals



\* only SPM5-241S

## Output Performances

Model	Input Voltage VAC	Output Power (W)	Output Voltage VDC	Current (A)	Typical Efficiency
SPM5-051	90~264	60	5	12.0	80%
SPM5-121	90~264	72	12	6.0	86%
SPM5-151	90~264	75	15	5.0	86%
SPM5-241	90~264	100.8	24	4.2	89%
SPM5-241S	90~264	91.2	24	3.8	89%

## Output Data

Line regulation	±1% max.		DC ON indicator	Min.	Max.
Load regulation	±1%		5V Model	3.5VDC	4.5VDC
Output Voltage accuracy	±1%		12V Model	9VDC	10.8VDC
Ripple and Noise	50mV		15V Model	11VDC	13.5VDC
Temperature Coefficient	±0.03%/°C		24V & 24V S	19.2VDC	21.6VDC
Hold up time	Vi = 115VAC	5V & 12V: 16ms 15V & 24V: 10ms	DC LOW indicator	Min.	Max.
	Vi = 230VAC	60ms	5V Model	3.5VDC	4.5VDC
Minimum load	0%		12V Model	9VDC	10.8VDC
Voltage trim range	Min.	Max.	15V Model	11VDC	13.5VDC
5V Model	5VDC	5.5VDC	24V & 24V S	19.2VDC	21.6VDC
12V Model	12VDC	14VDC	Turn on time (full resistive load)		
15V Model	13.5VDC	16.5VDC	Vi nom, Io nom	1000ms	
24V & 24V S	24VDC	28VDC	Vi nom, Io nom with 3500µF	1500ms	
Transient recovery time (50% load step changed)	2ms		Voltage rise time		
Voltage fall time (Io nom, Vi nom)	150ms		Vi nom, Io nom	150ms	
Capacitor load	3500µF		Vi nom, Io nom with 3500µF CAP	500ms	
			Rated continuous loading		
			5V Model	12A @ 5VDC / 10.5A @ 5.5VDC	
			12V Model	6A @ 12VDC / 5.1A @ 14VDC	
			15V Model	4.2A @ 24VDC / 3.6A @ 28VDC	
			24V Model	3.8A @ 24VDC / 3.7A @ 24.2VDC	

## Input Data

<b>Rated input voltage</b>	100/240VAC	<b>Input current</b>	
<b>Voltage range</b>		<b>Vi: 115/230VAC, 5V Model</b>	1.15 / 0.62A
AC in	90 - 264 VAC	<b>Io nom 12V, 15V Models</b>	1.35 / 0.72A
DC in	120 - 375 VDC	<b>24V Model</b>	1.8 / 0.9A
<b>Line frequency</b>	47 - 63Hz	<b>Power dissipation</b>	
<b>Inrush current</b>		<b>Vi: 230VAC, Io nom</b>	
Vi= 115VAC	Typ: 25A Max: 30A	<b>5V Model</b>	15.6W
Vi= 230VAC	Typ: 40A Max: 60A	<b>12V Model</b>	12.9W
<b>Leakage current</b>		<b>15V Model</b>	12.5W
<b>input-output</b>	0.25 mA	<b>24V Model</b>	12.2W

<sup>1)</sup> Fuse not replaceable by user

## General Data (@ nominal line, full load, 25°C )

<b>Insulation voltage</b>	3.000VAC	<b>Case material</b>	Plastic (PC-UL94-V0)
<b>Insulation resistance</b>	100MΩ	<b>Weight</b>	380g
<b>Ambient temperature</b>	-40°C to 71°C	<b>Protection degree</b>	IP20
<b>Derating (&gt;61°C to +71°C)<sup>2)</sup></b>	2.5%/°C	<b>MTBF</b> (Bellcore issue 6 @ 40°C, GB)	
<b>Ambient humidity</b>	20~95%RH	<b>5V Model</b>	566000 Hours
<b>Storage temperature</b>	-40°C to +85°C	<b>12V Model</b>	556000 Hours
<b>Dimensions L x W x D mm</b>	91 x 90 x 57	<b>15V Model</b>	564000 Hours
<b>L x W x D inches</b>	3.58 x 3.54 x 2.24	<b>24V Model</b>	525000 Hours
<b>Cooling</b>	Free air convection	<b>24LS Model</b>	527000 Hours

<sup>2)</sup> SPM5-051 derating starts from 56°C (132.8°F)

## Controls and Protections

<b>Input Fuse</b>	T3.15A/250VAC internal <sup>1)</sup>	<b>Over voltage protection</b>	<b>VDC</b>	
<b>Output Short Circuit</b>	Fold forward		<b>Min.</b>	<b>Max.</b>
<b>Rated Overload Protection</b>		<b>5V Model</b>	5.75	6.5
<b>5V, 12V, 15V &amp; 24V</b>	110-150%	<b>12V Model</b>	15	16.5
<b>24V S</b>	102-108%	<b>15V Model</b>	18	20
		<b>24V Model</b>	30	33
		<b>24LS Model</b>	24.5	25.5

## Approvals

<b>Vibration resistance</b>	meet IEC 60068-2-6 (Mounting by rail: 10-500 Hz, 2G, along X, Y, Z each Axis, 60 min for each Axis)	<b>CE</b>	EN61000-6-3, EN55022 class B, EN61000-3-2, EN61000-3-3, EN61000-6-2, EN55024, EN61000-4-2 Level 4, EN61000-4-3 Level 3, EN61000-4-4 Level 4, EN61000-4-5 L-N Level 3, EN61000-4-6 Level 3, EN61000-4-8 Level 4, EN61000-4-11, ENV 50204 Level 2, EN 61204-3
<b>Shock resistance</b>	meet IEC 60068-2-27 (15G, 11 ms, 3 Axis, 6 Faces, 3 times for each Face)		
<b>UL / cUL</b>	UL508 listed, UL 60950-1, UL1310 Class 2 Power (24LS model only) Recognized, ISA 12.12.01 (Class1. Division2, Groups A, B, C and D)		
<b>TUV</b>	EN60950-1, CB scheme		

## Block diagrams

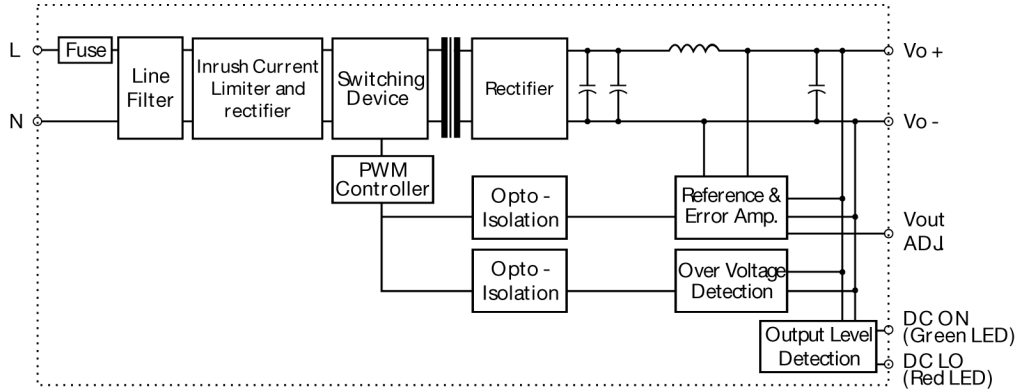

## Pin Assignment and Front Controls

Pin No.	Designation	Description
1	-	Negative output terminal
2	-	Negative output terminal
3	+	Positive output terminal
4	+	Positive output terminal
5	L	Input terminals (phase conductor, no polarity at DC input)
6	N	Input terminals (neutral conductor, no polarity at DC input)
	Vout ADJ	Trimmer-potentiometer for Vout adjustment
	DC ON	Operation indicator LED
	DC LO	DC Low indicator LED

## Derating Diagram

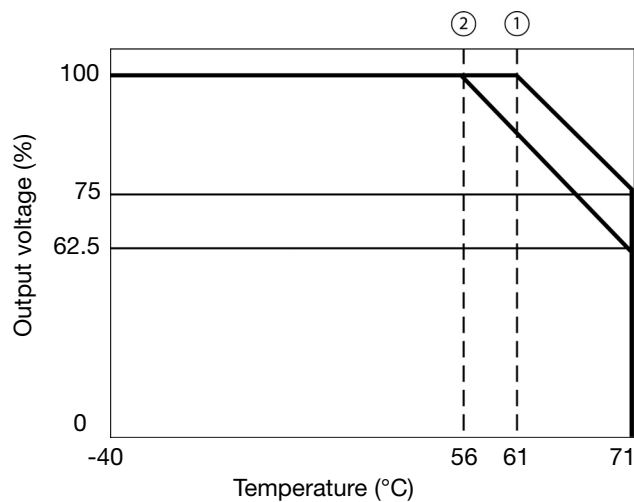

## Typ. Efficiency Curve

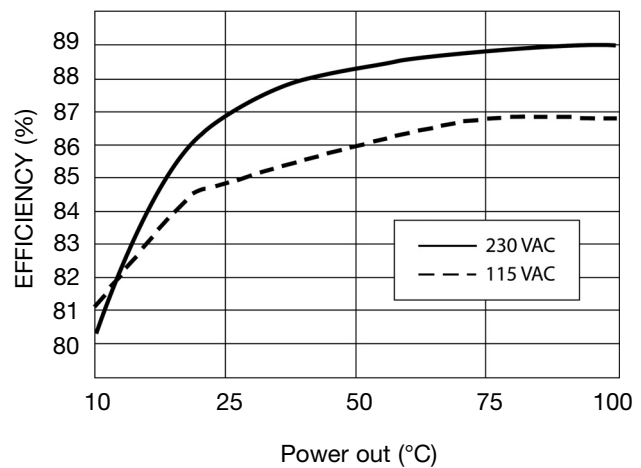

## Typ. Current Limited Curve

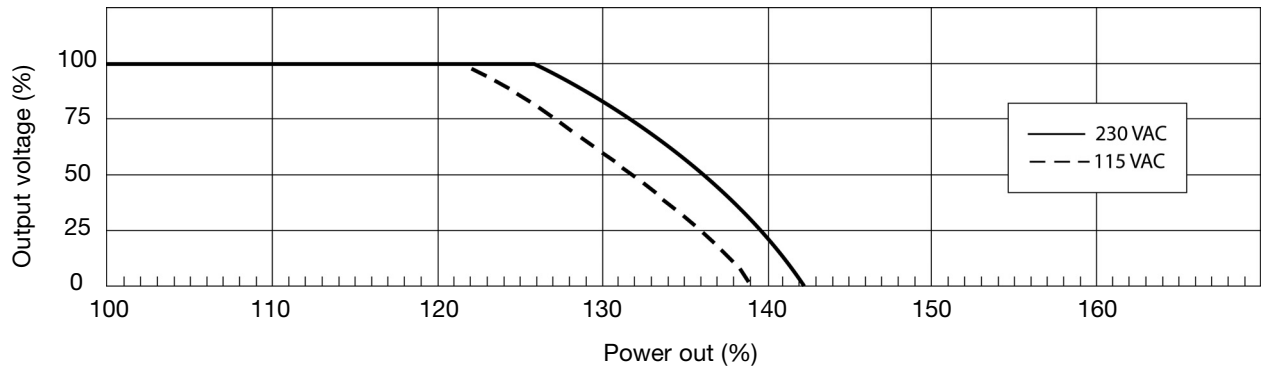

## Mechanical Drawings

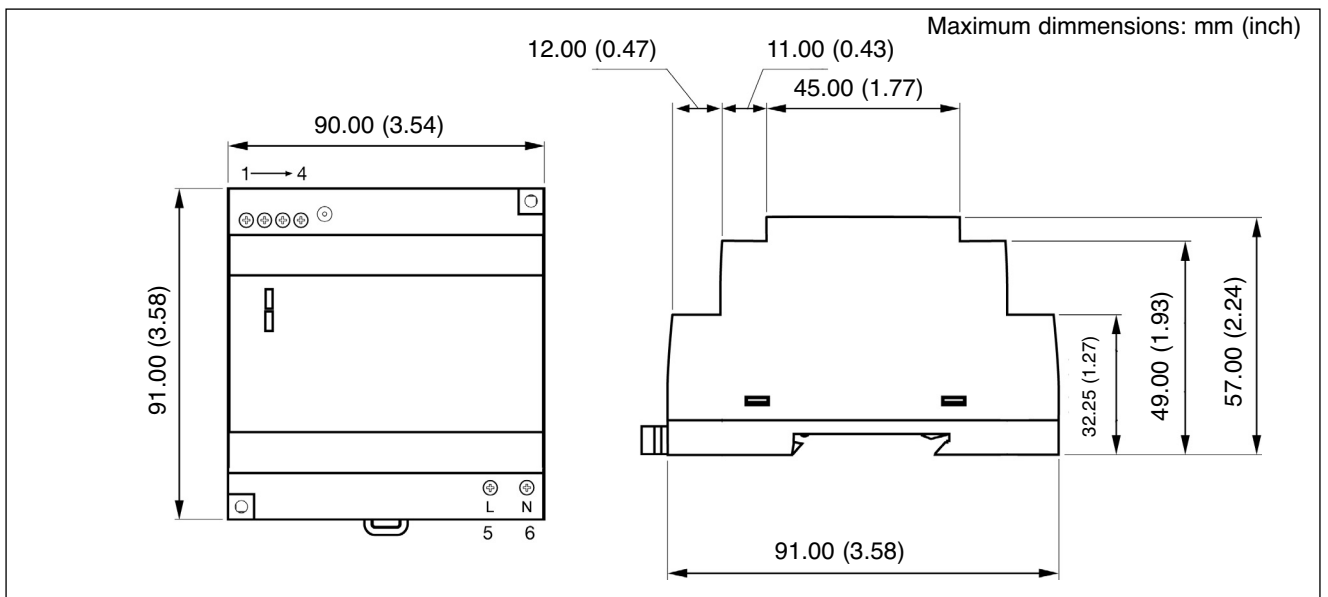

### Construction

Easy snap-on mounting onto the DIN-Rail (TS35/7.5 or TS35/15), unit sits safely and firmly on the rail; no tools required even to remove.

### Installation

<b>Ventilation and cooling</b>	Normal convection All sides 25mm free space for cooling is recommended
<b>Screw terminals</b>	24-14AWG flexible or solid cable (user copper conductors only)
<b>Max. torque for terminals</b>	
Input terminals	0.67Nm (6.0lb-in)
Output terminals	0.67Nm (6.0lb-in)