

Industrial HRC Fuse

13.8 x 58.7mm, BS88: Part 6, IEC 269-1
Offset Blade Tags

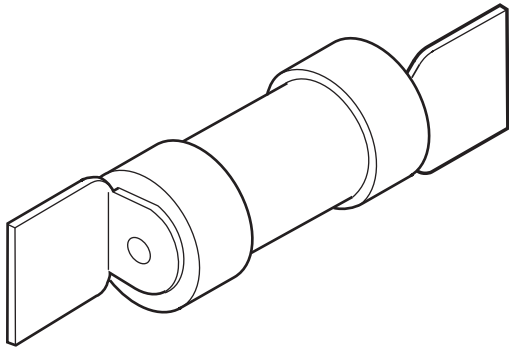

CATALOG SYMBOL: NSD
INDUSTRIAL HRC FUSE
OFFSET BLADE TAGS
PACKAGE QUANTITY: 20
80kA INTERRUPTING RATING
MOUNTS IN CAMLOC OR SAFELOC SERIES HOLDERS

Dimensional Data:

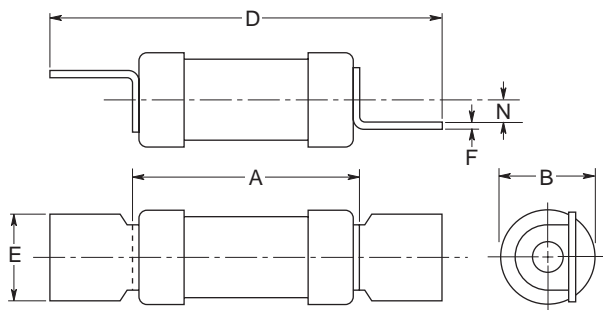

Time-Current Characteristic Curve (Full Size Curves Available)

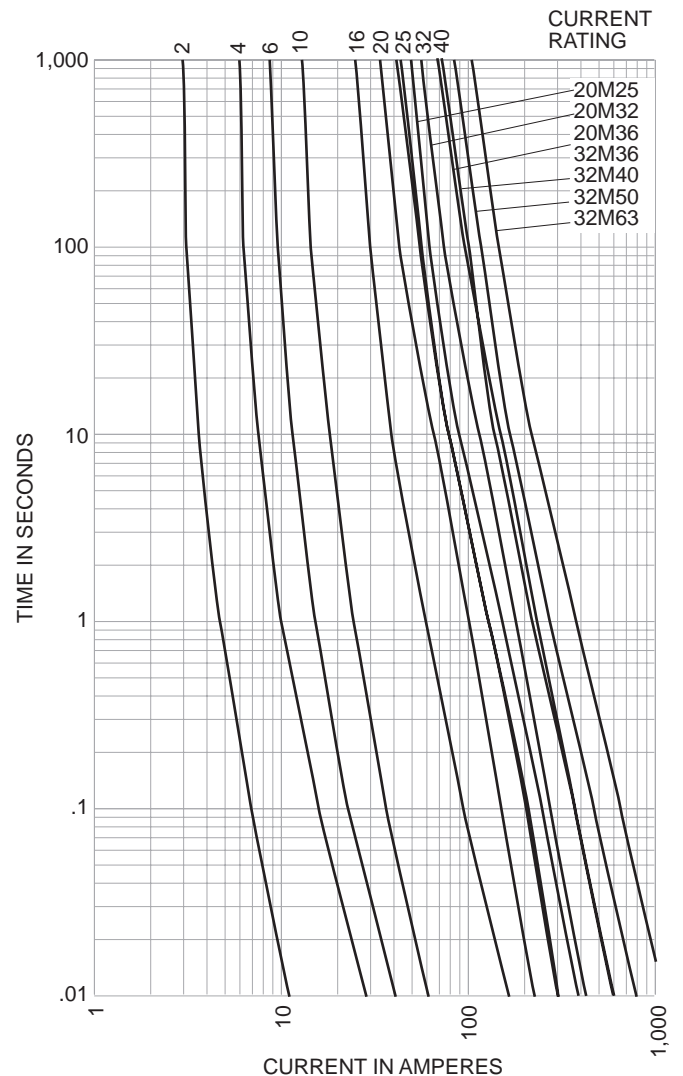

Electrical Characteristics

Catalog Number	Ampere Rating	I ² T (Amp ² Seconds)			Nom Watts Loss	Rated Voltage	Dimensions (Inches/mm)					
		Pre-Arcing	Total At 415V	Total At 550V			A	B	D	E	F	N
NSD2	2	1.3	4.6	5	0.9	550AC	34.6	.54 13.8	58.5	12.7	.03 .8	.14 3.5
NSD4	4	8	27	30	1.4							
NSD6	6	29	100	115	1.8							
NSD10	10	120	400	490	2.1							
NSD16	16	120	470	730	1.8							
NSD20	20	260	1070	1700	1.8							
NSD25	25	560	2300	3550	2							
NSD32	32	710	3000	5000	2.9	415AC	34.6	.69 17.5	58.5	12.7	.03 .8	.14 3.5
NSD20M25	20M25	570	2350	—	1.2							
NSD20M32	20M32	770	3000	—	0.95							
NSD20M36	20M36	1150	5000	—	0.88							
NSD32M36	32M36	1150	5000	—	2.4							
NSD32M40	32M40	1500	6000	—	1.9							
NSD32M50	32M50	2700	8700	—	1.4							
NSD32M63	32M63	5000	13,550	—	1.0							

This bulletin is intended to clearly present comprehensive product data and provide technical information that will help the end user with design applications. Bussmann reserves the right, without notice, to change design or construction of any products and to discontinue or limit distribution of any products. Bussmann also reserves the right to change or update, without notice, any technical information contained in this bulletin. Once a product has been selected, it should be tested by the user in all possible applications.

