



Catalog

Softstarters

Type PSR, PSS, PSE, PST and PSTB

Efficient PSE range – world's first compact softstarter with torque control

The latest addition to ABB's softstarter family is the efficient PSE range. This softstarter has been equipped with all the most important features making it a very efficient choice. During the development process, great focus has been put into making sure that both the softstarter and the process are even more reliable. Furthermore, the softstarter has been equipped with built-in by-pass to reduce wiring and a back-lit display to provide a hassle free and easy setup and monitoring.

The complete range of softstarters

ABB's softstarter portfolio now consists of four different ranges making it possible to find a suitable softstarter for almost any possible application and motor size all the way up to 1800 A. The softstarter family consists of the compact PSR, the flexible PSS, the efficient PSE and the advanced PST(B) range.

Semiconductor fuses changed to knife type

The Bussmann semiconductor fuses, recommended to be used together with PSS, PSE and PST(B) softstarters, have been changed from screw fixing (DIN43 653) to knife fixing (DIN43 620). This will make it possible to use the standard OS type switch fuses from ABB.



Contents

News	2	
Contents	3	
Softstarters	4	
Applications.....	6	
PSR - The compact range		
Description	8	
Overview	9	
Ordering details.....	10	
Accessories	11	
Technical data	12	
UL ratings	13	
PSS - The flexible range		
Description	14	
Overview	16	
Ordering details.....	18	
Accessories	22	
Technical data	23	
UL ratings	25	
PSE - The efficient range		
Description	26	
Overview	28	
Ordering details.....	30	
Accessories	32	
Technical data	33	
UL ratings	35	
PST(B) - The advanced range		
Description	36	
Overview	38	
Ordering details.....	40	
Accessories	44	
Technical data	45	
UL ratings	49	
FBP FieldBusPlug		
DeviceNET, MODBUS-RTU and CANopen.....	50	
Profibus DP	52	
Wall mounting instructions		54
Dimensions		55
Circuit diagrams		59
ProSoft (selection tool)		62
Coordination tables		62
Certifications and approvals		63

Softstarters

From the moment the first electric motor was developed, engineers have tried to come up with ways of avoiding the electrical and mechanical problems that usually occur when starting a motor. High inrush currents, current spikes and excessive mechanical wear are some of the problems that need to be avoided. One way is to use a Star-Delta starter. This method is for many applications an insufficient solution since it handles neither problems with current spikes or torque peaks nor provides a way to perform a soft stop. A softstarter on the other hand, will provide far better performance during the start and allows for soft stops of the motor.

ABB has been producing softstarters since the beginning of the 1980's. Over 30 years' experience has been incorporated into the design of today's product ranges. Modern power electronics matched with smart circuitry and software gives users of ABB's softstarters, with several state-of-the-art design features, superior control of current and voltage levels during motor start and stop.

The solution to both mechanical and electrical problems

AC motors, "the workhorses of the industry", are used to drive fans, crushers, agitators, pumps, conveyors and more. Depending on the motor installation, torque and current peaks occur. These peaks are everyday reality for production plants

all over the world, causing problems in several ways:

- Electrical problems due to voltage and current transients arising from Direct-On-Line or Star-Delta starts. The transients may overload the local supply network and cause unacceptable voltage variations that interfere with other electrical equipment connected to the network.
- Mechanical problems that address the entire drive chain, from motor to driven equipment, causing a big need for service and repair work.
- Operational problems, such as damage to products on conveyor belts.
- Water hammering and pressure surges in pipe systems when starting and stopping pumps.

The financial consequences of the problems above are considerable. Every technical problem and every breakdown costs money in repairs and lost production.

By choosing ABB's softstarter, all of these problems could be avoided. Whether the choice is the PSR, PSS, PSE or the PST(B), ABB's softstarters all allow smooth start and stops while keeping mechanical and electrical stresses to a minimum.

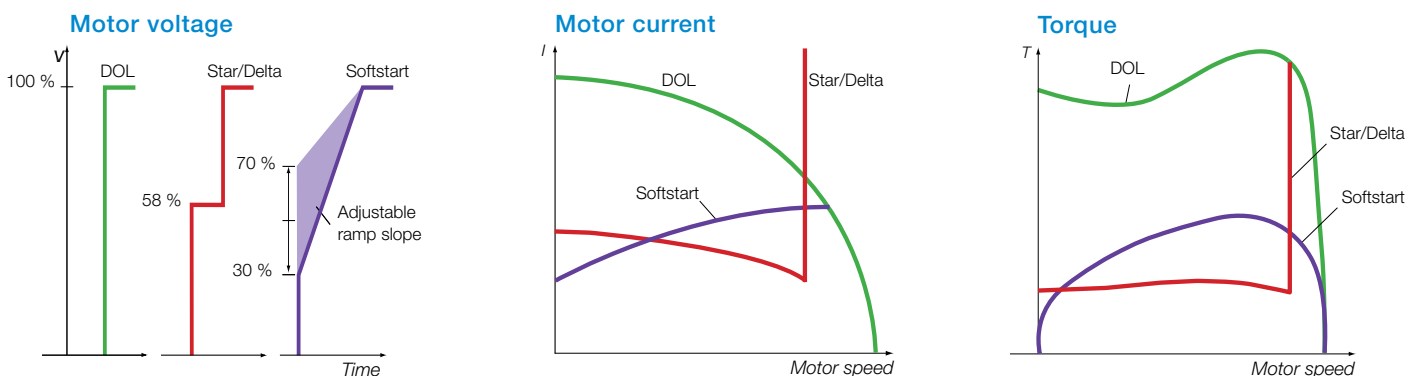

Graphs showing the basic differences between Direct-On-Line starting (DOL), Star-Delta starting and soft starting in terms of the motor voltage (V), motor current (I) and motor torque (T).

Softstarters

ABB's softstarters – The complete range

ABB offers four different ranges of softstarters to cover every customer need for solutions with motor sizes up to 1800 A. This page describes the main characteristics of the different softstarter ranges.

PSR – The compact range

The PSR softstarter is the most compact of all the softstarter ranges. A compact softstarter also allows for the design of compact starting equipment. A PSR together with a MMS (manual motor starter) makes up a far more compact starting solution than a Star-Delta starter, for instance.

By including a built-in by-pass the energy losses inside the softstarter are reduced. And with only three potentiometers, the setup of the PSR could not be easier. Still, the optimized ramping characteristics will ensure a very smooth start and stop for all applications.

PSS – The flexible range

The PSS is the most flexible of the four softstarter ranges from ABB. It allows both in-line and inside delta connections. As with the PSR, few settings are needed to get it up and running. Connecting an external current transformer makes it possible to activate the current limit function which will allow you to keep the current at a pre-set level also when starting heavy-duty applications. The PSS softstarter is the ideal solution when looking for a robust solid state starting solution where handling many starts per hour is required.

PSE – The efficient range

The PSE softstarter is the world's first compact softstarter with both built-in electronic overload for motor protection and torque control for excellent control of pumps. A compact design, packed with functionality, makes the PSE a very efficient starting solution.

An illuminated, language neutral display and a four button keypad makes it easy to take advantage of all the advanced features of the PSE softstarter. The display provides all the necessary information both during ramping and continuous operation.

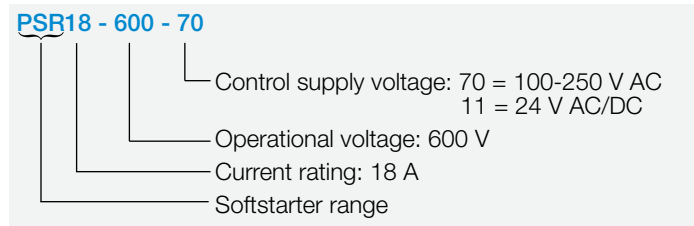

PST(B) – The advanced range

The PST(B) softstarter is the most advanced softstarter in the range with almost all imaginable functionality included. Advanced protection of the motor, softstarter and load ensures a trouble-free operation. Problems are detected before the motor needs to be stopped thanks to a pre-warning system that minimizes downtime.

The torque control of the PST(B) was developed in cooperation with well-known pump manufacturers to ensure the best possible stop of pumps, without the risk of water hammering and pressure surges.

With the full-text LCD display in your own language, pre-programmed application settings and event logging, setup and operation could not be easier.

By using the ABB's FieldBusPlug, you can decide at any time which bus protocol to use. The fieldbus system will allow you to setup, control and monitor the softstarter.

PSR	PSS	PSE	PST(B)	• Standard O Optional – Not available
•	–	•	• 1)	Built-in by-pass 1) on PSTB
–	•	–	•	Inside delta connection
–	–	•	O	Coated PCBs
–	–	•	•	Display and keypad
–	–	•	•	Torque control
–	O	•	•	Settable current limit function
–	–	•	•	Electronic motor overload protection
–	–	–	•	PTC input for motor protection
–	–	–	•	Phase imbalance protection
–	–	–	•	Phase reversal protection
–	–	•	•	Locked rotor protection
–	•	•	•	Thyristor overtemperature protection
–	–	•	•	Underload protection
–	–	–	•	Programmable warning functions
–	–	•	•	Analog output
O	–	O	•	FieldBus communication
–	–	O	•	Event log
–	–	O	O	External keypad

Applications

Pumps

Water is the most important resource in the world and water facilities can be found everywhere. Examples of water applications are freshwater and wastewater systems, circulating water for heating, cooling and irrigation.

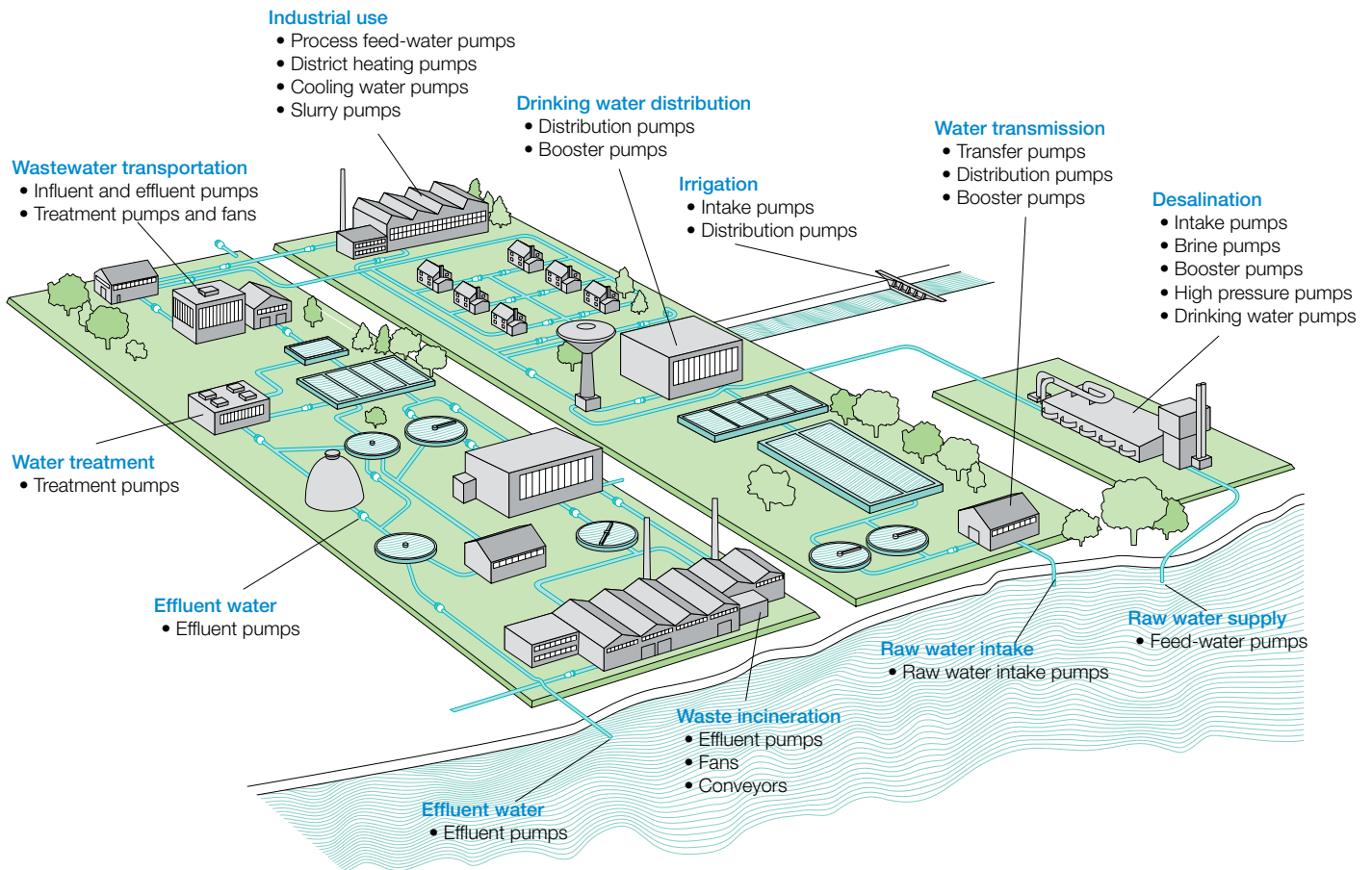

Common questions:

- How to avoid voltage drops when starting?
- ABB's softstarter will reduce the starting current and thereby avoid the voltage drops.
- How to avoid water hammering when stopping?
- Use our softstarters equipped with an optimized stop ramp. Or even better, with torque control.
- How to ensure high reliability in harsh environments?
- Use our softstarters equipped with coated circuit boards to better withstand those environments.
- How to protect my pumping equipment in the best possible way?
- Use ABB's softstarters equipped with our special designed protections such as overload, underload, and locked rotor protection.

Applications

Fans



Common questions:

- How to avoid extended voltage drops due to long starting time?
- Use ABB's softstarter equipped with current limit to keep control of the starting current.
- How to extend the life of the driving belts?
- Our softstarters will reduce the mechanical stress during start, thus avoiding slipping belts.
- How to ensure the operation of the fan?
- A softstarter with underload protection will detect broken belts, making the operator immediately aware of the problem.

Compressors



Common questions:

- How to ensure a long life of the compressor?
- Using a softstarter for starting will reduce the accelerating torque, thereby minimizing the mechanical stress.
- How to build a compact compressor unit?
- Using a compact softstarter like PSR or PSE will allow a much more compact starting equipment than for instance a Star-Delta starter.

Conveyor belts



Common questions:

- How to reduce the need for service and repair of the conveyor belt?
- A softstarter from ABB will ensure starts with minimal mechanical stress on the conveyor belt.
- How to avoid that the conveyor belt is running in the wrong direction?
- Use a softstarter with phase reversal protection.
- How to improve the efficiency of the conveyor belt?
- Using softstarters with high and low current warnings allow you to load on and off the conveyor belt.
- How to ensure a successful start even after longer times without operation?
- A softstarter with kick start function will provide sufficient torque to be able to overcome the initial high friction from a temporary jammed belt.

PSR – The compact range

Description



Product description

- Wide rated operational voltage 208–600 V
- Rated control supply voltage 24 V AC/DC or 100–240 V AC
- Rated operational current 3–105 A
- Wide ambient temperature range, -25 to +60 °C
- Built-in by-pass on all sizes, saving energy and reducing installation time
- Potentiometer settings
- Run signal relay on all devices
- TOR signal relay on PSR25 ... PSR105
- Optional fieldbus communication using Profibus, Modbus, Devicenet or CANopen
- DIN rail mounting on PSR3 ... PSR45
- Screw mounting on all sizes
- Connection kits for easy connection with ABB's manual motor starters
- Sophisticated algorithm eliminating the DC-component and thereby providing excellent starting performance

The PSR range is the most compact of all ABB's softstarter ranges. The compact PSR range makes it possible to fit many devices into the same enclosure. A PSR together with a MMS (manual motor starter) makes up a far more compact starting solution than a Star-Delta starter, for instance.

Flexible mounting

PSR softstarters from 3 to 45 A are possible to mount on a DIN-rail, ensuring quick and easy mounting. Naturally, all sizes can be screw mounted.

Few settings

The setup of the PSR is easily done and confirmed using the three clearly marked potentiometers on the front.

Built-in by-pass for energy saving

The built-in by-pass on all sizes does not only save energy; it will also ensure the most compact ABB's softstarter design and reduce the installation time. Thanks to the reduced heat generation, the softstarter can be mounted inside high IP class enclosures.

Suitable for stopping pumps

Even without using torque control, the PSR range is designed to reduce water hammering. Compared to the direct stops of a Star-Delta starter or a DOL starter the PSR is superior. See the stop ramp with step-down voltage below.

System concept with manual motor starters

All PSR softstarter sizes can easily be connected to the corresponding manual motor starters from ABB by using the special designed connection kits. This makes both the mounting and the connection easier and will provide a very compact starting solution containing short circuit and thermal protection, isolation function and soft starter - everything that you need.

Settings

- ① Start = 1 ... 20 sec
Stop = 0 ... 20 sec - including the step down voltage.
- ② Step down = 2% reduction for each second increased stop ramp
Stop ramp 10 sec -> step down 80% (20% reduction)
- ③ U_{ini} = 40 ... 70% results in end voltage = 30 ... 60%

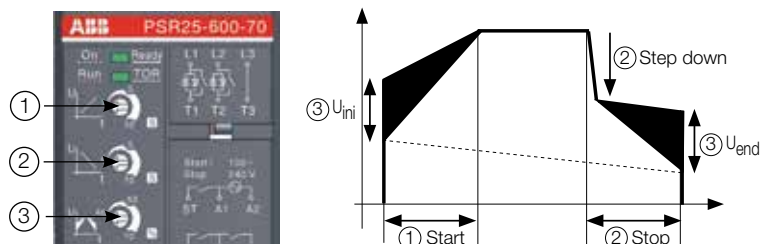

PSR – The compact range

Overview



	PSR3 ... PSR16				PSR25 ... PSR30		PSR37... PSR45		PSR60 ... PSR105				
	Softstarter, type												
Normal start	PSR3	PSR6	PSR9	PSR12	PSR16	PSR25	PSR30	PSR37	PSR45	PSR60	PSR72	PSR85	PSR105
In-line connected													
(400 V) kW	1.5	3	4	5.5	7.5	11	15	18.5	22	30	37	45	55
IEC, max. A	3.9	6.8	9	12	16	25	30	37	45	60	72	85	105
(440-480 V) hp	2	3	5	7.5	10	15	20	25	30	40	50	60	75
UL, max FLA	3.4	6.1	9	11	15.2	24.2	28	34	46.2	59.4	68	80	104
	400 V, 40 °C												
Using manual motor starters type 1 coordination will be achieved	Manual motor starter (50 kA) type												
	MS116			MS132			MS450		MS495		—		
Using gG fuses type 1 coordination will be achieved	Fuse protection (50 kA) gG Fuse												
	10 A	16 A	25 A	32 A	50 A	63 A	100 A	125 A	200 A	250 A			
Suitable switch fuse for the above gG fuses	Switch fuse, type												
	OS32GD				OS125GD				OS250D				
Overload protection is used to protect the motor from over heating	Thermal overload relay												
	TF42DU						TA75DU			TA110DU			
The line contactor is not required for the softstarter itself but often used to open if OL trips	Line contactor, type												
	AF9		AF12	AF16	AF26	AF30	AF38	A50	A63	A75	A95	A110	
Using by-pass will reduce the power loss and allow more starts per hour	By-pass contacts												
	Built-in												

PSR – The compact range

Ordering details



PSR3 ... PSR105

Rated operational voltage U_e , 208-600 V AC

Rated control supply voltage, U_s , 100-240 V AC

Motor power

230 V P_e kW	400 V P_e kW	500 V P_e kW	IEC Max rated operational current I_e A	Type	Order code	Weight kg 1 piece
0.75	1.5	2.2	3.9	PSR3-600-70	1SFA896103R7000	0.450
1.5	3	4	6.8	PSR6-600-70	1SFA896104R7000	0.450
2.2	4	4	9	PSR9-600-70	1SFA896105R7000	0.450
3	5.5	5.5	12	PSR12-600-70	1SFA896106R7000	0.450
4	7.5	7.5	16	PSR16-600-70	1SFA896107R7000	0.450
5.5	11	15	25	PSR25-600-70	1SFA896108R7000	0.650
7.5	15	18.5	30	PSR30-600-70	1SFA896109R7000	0.650
7.5	18.5	22	37	PSR37-600-70	1SFA896110R7000	1.000
11	22	30	45	PSR45-600-70	1SFA896111R7000	1.000
15	30	37	60	PSR60-600-70	1SFA896112R7000	2.200
22	37	45	72	PSR72-600-70	1SFA896113R7000	2.270
22	45	55	85	PSR85-600-70	1SFA896114R7000	2.270
30	55	55	105	PSR105-600-70	1SFA896115R7000	2.270



PSR3 ... PSR16



PSR25 ... PSR30



PSR37 ... PSR45



PSR60 ... PSR105

Rated operational voltage U_e , 208-600 V AC

Rated control supply voltage, U_s , 24 V AC/DC

0.75	1.5	2.2	3.9	PSR3-600-11	1SFA896103R1100	0.450
1.5	3	4	6.8	PSR6-600-11	1SFA896104R1100	0.450
2.2	4	4	9	PSR9-600-11	1SFA896105R1100	0.450
3	5.5	5.5	12	PSR12-600-11	1SFA896106R1100	0.450
4	7.5	7.5	16	PSR16-600-11	1SFA896107R1100	0.450
5.5	11	15	25	PSR25-600-11	1SFA896108R1100	0.650
7.5	15	18.5	30	PSR30-600-11	1SFA896109R1100	0.650
7.5	18.5	22	37	PSR37-600-11	1SFA896110R1100	1.000
11	22	30	45	PSR45-600-11	1SFA896111R1100	1.000
15	30	37	60	PSR60-600-11	1SFA896112R1100	2.200
22	37	45	72	PSR72-600-11	1SFA896113R1100	2.270
22	45	55	85	PSR85-600-11	1SFA896114R1100	2.270
30	55	55	105	PSR105-600-11	1SFA896115R1100	2.270

PSR – The compact range

Accessories



PSR16-MS116

PSR30-MS132



PSR45-MS450

PSR105-MS495



PSR-FAN3-45A

PSR-FAN60-105A



PS-FBPA

Connection kit

For softstarter type	Type	Order code	Pack ^{ing} piece	Weight kg 1 piece
PSR3...PSR16 with MS116 or MS132	PSR16-MS116	1SFA896211R1001	1	0.022
PSR25...PSR30 with MS132-12...MS132-32	PSR30-MS132	1SFA896212R1001	1	0.040
PSR37...PSR45 with MS450	PSR45-MS450	1SFA896213R1001	1	0.034
PSR60...PSR105 with MS495	PSR105-MS495	1SAM501903R1001	1	0.050

Fan

For softstarter type	Type	Order code	Pack ^{ing} piece	Weight kg 1 piece
PSR3...PSR45	PSR-FAN3-45A	1SFA896311R1001	1	0.010
PSR60...PSR105	PSR-FAN60-105A	1SFA896313R1001	1	0.013

Terminal enlargements

For softstarter type	Type	Order code	Pack ^{ing} piece	Weight kg 1 piece
PSR60...105 Wire range mm ² 1x10...50, 2x10...25	PSLW-72	1SFA899002R1072	1	0.150

FieldBusPlug connection accessory

For softstarter type	Type	Order code	Pack ^{ing} piece	Weight kg 1 piece
The same accessory for all sizes	PS-FBPA	1SFA896312R1002	1	0.060

ABB's FieldBusPlug suitable for all sizes. See page 50-53

Connection kit

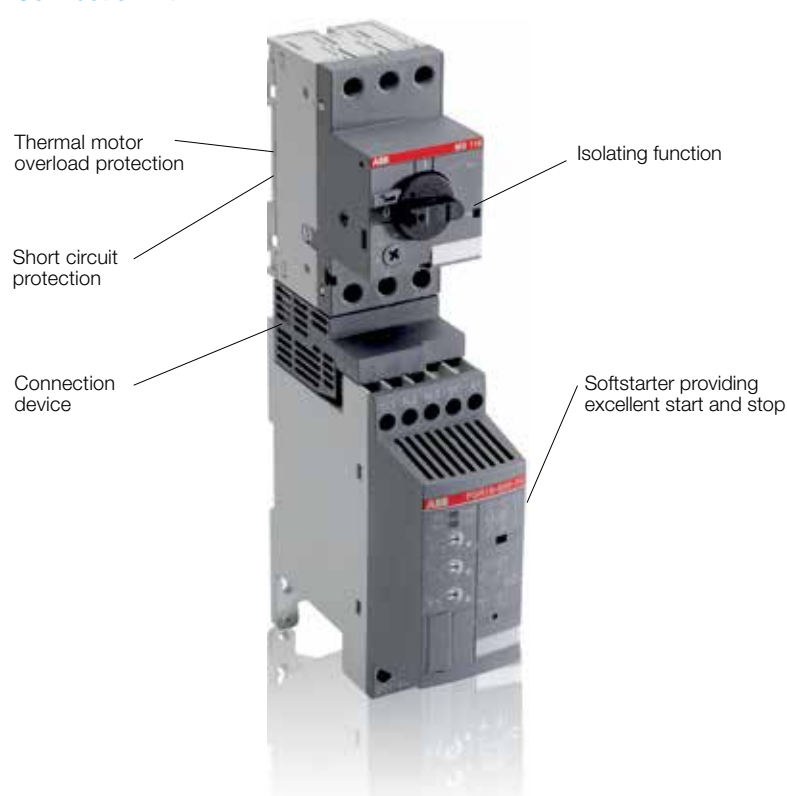

PSR – The compact range

Technical data

Rated insulation voltage U_i	600 V													
Rated operational voltage U_o	208...600 V +10%/-15%, 50/60 Hz \pm 5%													
Rated control supply voltage U_c	100...240 V AC, 50/60Hz \pm 5% or 24 V AC/DC, +10%/-15%													
Power consumption	PSR3	PSR6	PSR9	PSR12	PSR16	PSR25	PSR30	PSR37	PSR45	PSR60	PSR72	PSR85	PSR105	
Supply circuit	12 VA						10 VA							
at 100-240 V AC	12 VA						10 VA							
at 24 V AC/DC	5 W													
Max. Power loss at rated I_o	PSR3	PSR6	PSR9	PSR12	PSR16	PSR25	PSR30	PSR37	PSR45	PSR60	PSR72	PSR85	PSR105	
	0.7 W	2.9 W	6.5 W	11.5 W	20.5 W	25 W	36 W	5.5 W	8.1 W	3.6 W	5.2 W	7.2 W	6.6 W	
Starting capacity at I_o	4 x I_e for 6 sec.													
Number of starts per hour	See table below for details													
standard	10 ¹⁾													
with aux. fan	20 ¹⁾													
Service factor	100%													
Ambient temperature														
during operation	-25 °C to +60 °C ²⁾													
during storage	-40 °C to +70 °C													
Maximum altitude	4000 m ³⁾													
Degree of protection	PSR3	PSR6	PSR9	PSR12	PSR16	PSR25	PSR30	PSR37	PSR45	PSR60	PSR72	PSR85	PSR105	
main circuit	IP20						IP10							
control circuit	IP20						IP10							
Connectable cable area														
main circuit	PSR3-PSR16				PSR25-PSR30			PSR37-PSR45		PSR60-PSR105				
	1 x 0.75-2.5mm ²				1 x 2.5-10mm ²			1 x 6-35mm ²		1 x 10-95mm ²				
control circuit	2 x 0.75-2.5mm ²				2 x 2.5-10mm ²			2 x 6-16mm ²		2 x 6-35mm ²				
	PSR3-PSR16				PSR25-PSR105			PSR25-PSR105		PSR25-PSR105				
control circuit	1 x 0.75-2.5mm ²				1 x 0.75-2.5mm ²			1 x 0.75-2.5mm ²		1 x 0.75-2.5mm ²				
	2 x 0.75-2.5mm ²				2 x 0.75-2.5mm ²			2 x 0.75-1.5mm ²		2 x 0.75-1.5mm ²				
Signal relays														
for run signal	PSR3-PSR16				PSR25-PSR105					PSR25-PSR105				
	resistive load	240 V AC, 3 A/24 V DC, 3 A				240 V AC, 3 A/24 V DC, 3 A					240 V AC, 3 A/24 V DC, 3 A			
AC-15 (contactor)	240 V AC, 0.5 A/24 V DC, 0.5 A				240 V AC, 0.5 A/24 V DC, 0.5 A					240 V AC, 0.5 A/24 V DC, 0.5 A				
for top ramp signal	-				-					-				
	resistive load	-				-					240 V AC, 3 A/24 V DC, 3 A			
AC-15 (contactor)	-				-					240 V AC, 0.5 A/24 V DC, 0.5 A				
LED	for On/Ready	green												
	for Run/Top of ramp	green												
Settings	Ramp time during start	1-20 sec.												
	Ramp time during stop	0-20 sec.												
	Initial- and end voltage	40-70%												

¹⁾ Valid for 50% on time and 50% off time. If other data is required, contact your sales office.

²⁾ Above 40 °C up to max. 60 °C reduce the rated current with 0.8% per °C.

³⁾ When used at high altitudes above 1000 meters up to 4000 meters you need to derate the rated current using the following formula.

$$[\% \text{ of } I_o = 100 - \frac{x-1000}{150}] \quad x = \text{actual altitude for the softstarter}$$

Number of starts per hour using PSR softstarters

Motor current I_o	Starts/hour without auxiliary fan							Starts/hour with auxiliary fan												
	10	20	30	40	50	60	80	100	10	20	30	40	50	60	80	100				
3 A	PSR3							PSR6												
6 A	PSR6				PSR9			PSR9												
9 A	PSR9		PSR12			PSR16		PSR25		PSR12										
12 A	PSR12		PSR16		PSR25		PSR30		PSR25		PSR16					PSR25				
16 A	PSR16		PSR25		PSR30		PSR37		PSR16		PSR25			PSR30						
25 A	PSR25		PSR30		PSR37		PSR45		PSR60		PSR25		PSR30		PSR37		PSR45			
30 A	PSR30		PSR37		PSR45		PSR60		PSR72		PSR30		PSR37		PSR45					
37 A	PSR37		PSR45		PSR60		PSR72		PSR85		PSR105		PSR37		PSR45		PSR60			
45 A	PSR45		PSR60		PSR72		PSR85		PSR105		-		PSR45		PSR60		PSR72			
60 A	PSR60		PSR72		PSR85		PSR105		-		-		PSR60		PSR72		PSR85		PSR105	
72 A	PSR72		PSR85		PSR105		-		-		-		PSR72		PSR85		PSR105		-	
85 A	PSR85		PSR105		-		-		-		-		PSR85		PSR105		-		-	
105 A	PSR105		-		-		-		-		-		PSR105		-		-		-	

Data based on an ambient temperature of 40°, starting current of 4 x I_o and ramp time 6 seconds.

For more optimized selections, or to use PSR for heavy-duty starts, please use the softstarter selection tool.

PSR – The compact range

UL ratings

UL ratings

Softstarter Type	Motor power P (hp) and full load current FLA (A)					Max. fuse A, Type
	Max FLA A	U _e 200 V/208 V hp	U _e 220 V/240 V hp	U _e 440 V/480 V hp	U _e 550 V/600 V hp	
PSR3	3.4	0.5	0.75	2	2	35 A J-Type
PSR6	6.1	1	1.5	3	5	35 A J-Type
PSR9	9	2	2	5	7.5	35 A J-Type
PSR12	11	3	3	7.5	10	35 A J-Type
PSR16	15.2	3	5	10	10	35 A J-Type
PSR25	24.2	7.5	7.5	15	20	60 A J-Type
PSR30	28	7.5	10	20	25	60 A J-Type
PSR37	34	10	10	25	30	90 A J-Type
PSR45	46.2	15	15	30	40	90 A J-Type
PSR60	59.4	20	20	40	50	110 A J-Type
PSR72	68	20	25	50	60	125 A J-Type
PSR85	80	25	30	60	75	150 A J-Type
PSR105	104	30	40	75	100	200 A J-Type



PSS – The flexible range

Description



Product description

- Rated operational voltage 208–690 V AC
- Rated control supply voltage 110–120 V AC or 220–240 V AC
- Rated operational current 18–300 A (Up to 515 A inside delta)
- Wide ambient temperature range, -25 to +60 °C
- Settings done by rotating switches
- Designed for continuous operation without by-pass
- By-pass signal relay allowing easy control of external by-pass contactor
- Fault signal relay (NO or NC)
- Current limit function as an option

The PSS is the most flexible of the four softstarter ranges from ABB. It allows both in-line and inside delta connections. It is the ideal solution when looking for a robust solid state starting solution where many starts per hour are required.

Flexible connection

The PSS softstarter can be connected both in line and inside delta. The inside delta connection makes it possible to select a smaller size softstarter matching the inside delta current. All functionality will still remain the same.

Replacement for Star-Delta starters

As the PSS can be connected inside-delta it makes for a cost-efficient replacement of an existing Star-Delta starter. You can reuse the two sets of motor cables as well as the contactors and thermal overload.

Solid state starting solution

The robust design of the PSS softstarter has no moving mechanical parts. It is dimensioned to handle many starts per hour, which can be required for, e.g., elevator applications.

Few settings

The setup of the PSS softstarter is easily done using the three rotating switches to adjust the start and stop and the dip switch to select between in-line or inside-delta connection. This will also give a quick and easy overview of the used settings.

Possible to use current limit

Using an external current transformer will make it possible to activate the current limit function. This will allow you to keep the current at a pre-set level also when starting heavy-duty applications.

PSS – The flexible range

Description

The PSS softstarter can be selected according to the rated motor power in normal duty applications like pumps, compressors, elevators, escalators, short conveyor belts and bow thrusters. See page 18-19. For heavy-duty applications like centrifugal fans, crushers, mixers, mills, stirrers and long conveyor belts, select a softstarter from page 20-21.

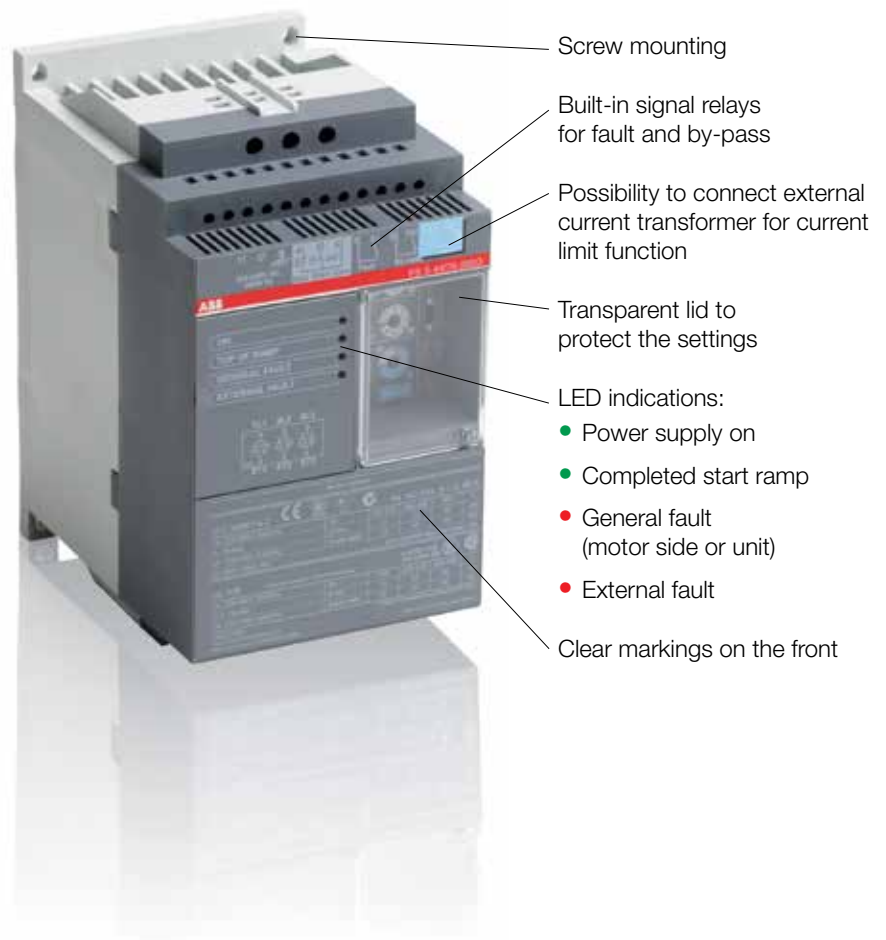
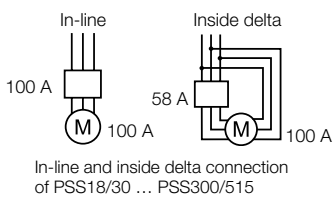

Settings

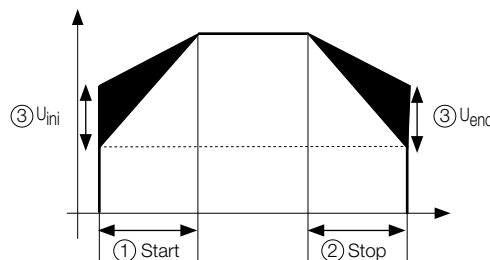
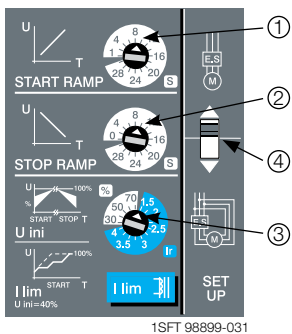

- Ramp time START = 1 ... 30 sec
- Ramp time STOP = 0 ... 30 sec
- Initial voltage U_{ini} and end voltage = 40 ... 70%
Level of current limit = 1.5 ... $4xI_e$
When current limit is used, initial voltage and end voltage is fixed at 40%
- Switch for in-line or inside delta connection

PSS – The flexible range

Overview



PSS18/30...PSS44/76

PSS50/85...PSS72/124

Normal start
In-line connected

(400 V) kW
IEC, max. A
(440-480 V) hp
UL, max FLA

Softstarter, type

PSS18/30	PSS30/52	PSS37/64	PSS44/76	PSS50/85	PSS60/105	PSS72/124
7.5	15	18.5	22	25	30	37
18	30	37	44	50	60	72
10	20	25	30	30	40	50
18	28	34	40	47	56	67

400 V, 40° C

Using MCCB type 1
coordination will be
achieved

MCCB (50 kA), type

T2S160

To achieve type 2 coordina-
tion semi-conductor fuses
must be used

Fuse protection (65 kA), semi-conductor fuses, Bussmann, type

170M1564	170M1566	170M1568	170M1569	170M1570	170M1571
----------	----------	----------	----------	----------	----------

Suitable switch fuse for
the recommended semi-
conductor fuses

Switch fuse, type

OS32GD03P

OS63GD03P

OS125GD03P

Overload protection is used
to protect the motor from
over heating

Thermal overload relay, type

TF42DU

TA75DU

The line contactor is not
required for the softstarter
itself but often used to
open if OL trips

Line contactor, type

AF16

AF30

AF38

A50

A63

A75

The by-pass contactor will
reduce the power loss of
the softstarter. All softstar-
ters can be operated
without by-pass

By-pass contactor, type

AF9

AF16

AF26

AF30

A40

A50

Must be used if current limit
function is required

Current transformers, type

PSCT-30
1 turn

PSCT-40
1 turn

PSCT-50
1 turn

PSCT-60
1 turn

PSCT-75
1 turn

PSCT-100
1 turn

A50 ... A300 might be replaced by AF50 ... AF300

The table above is an overview of possible combinations of devices.

Complete coordination tables are available at www.abb.com/lowvoltage

PSS – The flexible range

Overview



	PSS85/147...PSS142/245			PSS175/300...PSS300/515		
	Softstarter, type					
Normal start In-line connected	PSS85/147	PSS105/181	PSS142/245	PSS175/300	PSS250/430	PSS300/515
	45	55	75	90	132	160
	85	105	142	175	250	300
	60	75	100	125	150	200
(400 V) kW	85	105	142	175	250	300
IEC, max. A	60	75	100	125	150	200
(440-480 V) hp	85	105	125	156	225	248
UL, max FLA	400 V, 40 °C					
	MCCB (50 kA), type					
Using MCCB type 1 coordination will be achieved	T2S160	T3S250		T4S320	T5S400	
	Fuse protection (65 kA), semiconductor fuses, Bussmann, type					
To achieve type 2 coordination semi-conductor fuses must be used	170M1572	170M3819	170M5809	170M5810	170M5813	170M6813
	Switch fuse, type					
Suitable switch fuse for the recommended semi-conductor fuses	OS125GD03P	OS250D03P	OS400D03P		OS630D03P	
	Thermal overload relay, type					
Overload protection is used to protect the motor from over heating	TA110DU		TA200DU		TA450DU	
	Line contactor, type					
The line contactor is not required for the softstarter itself but often used to open if OL trips	A95	A110	A145	A185	A260	A300
	By-pass contactor, type					
The by-pass contactor will reduce the power loss of the softstarter. All softstarters can be operated without by-pass	A50	A63	A95	A145	A210	
	Current transformers, type					
Must be used if current limit function is required	PSCT-125 1 turn	PSCT-150 1 turn	PSCT200 1 turn	PSCT-250 1 turn	PSCT-400 1 turn	

How to select correct size

By using the guide here, you can quickly select a suitable softstarter for the most common applications.

If a more precise selection is required, you can use the softstarter selection tool available at www.abb.com/lowvoltage

Quick guide for selection

Normal start class 10

Ordering - see page 18-19

Heavy-duty start class 30

Ordering - see page 20-21



Typical applications

- Bow thruster
- Centrifugal pump
- Centrifugal fan
- Conveyor belt (long)
- Compressor
- Conveyor belt (short)
- Crusher
- Mill
- Elevator
- Escalator
- Mixer
- Stirrer

! If more than 10 starts/h
Select one size larger than the standard selection

PSS – The flexible range

Normal starts, class 10, in-line, ordering details



PSS18/30 ... PSS300/515

Rated operational voltage, U_s , 208-500 V

Motor power

400 V P kW	500 V P kW	690 V P kW	IEC Max rated operational current I_s A	Type ^{*)}	Order code ^{**)}	Weight kg 1 piece
7.5	11	-	18	PSS18/30-500□■	1SFA892001R▽00▼	2.30
15	18.5	-	30	PSS30/52-500□■	1SFA892002R▽00▼	2.30
18.5	22	-	37	PSS37/64-500□■	1SFA892003R▽00▼	2.30
22	25	-	44	PSS44/76-500□■	1SFA892004R▽00▼	2.30
25	30	-	50	PSS50/85-500□■	1SFA892005R▽00▼	3.60
30	37	-	60	PSS60/105-500□■	1SFA892006R▽00▼	3.80
37	45	-	72	PSS72/124-500□■	1SFA892007R▽00▼	3.80
45	55	-	85	PSS85/147-500□■	1SFA892008R▽00▼	8.60
55	75	-	105	PSS105/181-500□■	1SFA892009R▽00▼	10.40
75	90	-	142	PSS142/245-500□■	1SFA892010R▽00▼	10.40
90	110	-	175	PSS175/300-500□■	1SFA892011R▽00▼	20.50
132	160	-	250	PSS250/430-500□■	1SFA892013R▽00▼	22.00
160	200	-	300	PSS300/515-500□■	1SFA892014R▽00▼	22.00



PSS18/30-500 ... 44/76-500



PSS50/85-500 ... 72/124-500
PSS18/30-690 ... 72/124-690



PSS85/147-500 ... 142/245-500
PSS85/147-690 ... 142/245-690



PSS175/300-500 ... 300/515-500
PSS175/300-690 ... 300/515-690

Rated operational voltage, U_s , 400-690 V

7.5	11	15	18	PSS18/30-690□■	1SFA893001R▽00▼	2.30
15	18.5	25	30	PSS30/52-690□■	1SFA893002R▽00▼	2.30
18.5	22	30	37	PSS37/64-690□■	1SFA893003R▽00▼	2.30
22	25	37	44	PSS44/76-690□■	1SFA893004R▽00▼	2.30
25	30	45	50	PSS50/85-690□■	1SFA893005R▽00▼	3.60
30	37	55	60	PSS60/105-690□■	1SFA893006R▽00▼	3.80
37	45	59	72	PSS72/124-690□■	1SFA893007R▽00▼	3.80
45	55	75	85	PSS85/147-690□■	1SFA893008R▽00▼	8.60
55	75	90	105	PSS105/181-690□■	1SFA893009R▽00▼	10.40
75	90	132	142	PSS142/245-690□■	1SFA893010R▽00▼	10.40
90	110	160	175	PSS175/300-690□■	1SFA893011R▽00▼	20.50
132	160	220	250	PSS250/430-690□■	1SFA893013R▽00▼	22.00
160	200	257	300	PSS300/515-690□■	1SFA893014R▽00▼	22.00

^{*)} Add code letter in type for:
Rated control supply voltage, U_s
□ F = 110-120 V, 50/60 Hz
L = 220-240 V, 50/60 Hz
Fault signal relay
■ no code letter = NO
C = NC

^{**)} Add code number in order code for:
Fault signal relay
▽ 1 = NO
2 = NC
Rated control supply voltage, U_s
▼ 1 = 110-120 V, 50/60 Hz
2 = 220-240 V, 50/60 Hz

PSS – The flexible range

Normal starts, class 10, inside delta, ordering details



PSS18/30 ... PSS300/515

Rated operational voltage, U_o , 208-500 V

Motor power

400 V P_e kW	500 V P_e kW	690 V P_e kW	IEC Max rated operational current I_o A	Type*)	Order code**)	Weight kg 1 piece
15	18.5	-	30	PSS18/30-500□■	1SFA892001R▽00▼	2.30
25	30	-	52	PSS30/52-500□■	1SFA892002R▽00▼	2.30
30	37	-	64	PSS37/64-500□■	1SFA892003R▽00▼	2.30
37	45	-	76	PSS44/76-500□■	1SFA892004R▽00▼	2.30
45	55	-	85	PSS50/85-500□■	1SFA892005R▽00▼	3.60
55	75	-	105	PSS60/105-500□■	1SFA892006R▽00▼	3.80
59	80	-	124	PSS72/124-500□■	1SFA892007R▽00▼	3.80
75	90	-	147	PSS85/147-500□■	1SFA892008R▽00▼	8.60
90	110	-	181	PSS105/181-500□■	1SFA892009R▽00▼	10.40
132	160	-	245	PSS142/245-500□■	1SFA892010R▽00▼	10.40
160	200	-	300	PSS175/300-500□■	1SFA892011R▽00▼	20.50
220	295	-	430	PSS250/430-500□■	1SFA892013R▽00▼	22.00
257	355	-	515	PSS300/515-500□■	1SFA892014R▽00▼	22.00



1SFC132301F0002

PSS18/30-500 ... 44/76-500



1SFC132302F0002

PSS50/85-500 ... 72/124-500
PSS18/30-690 ... 72/124-690

Rated operational voltage, U_o , 400-690 V

15	18.5	25	30	PSS18/30-690□■	1SFA893001R▽00▼	2.30
25	30	45	52	PSS30/52-690□■	1SFA893002R▽00▼	2.30
30	37	55	64	PSS37/64-690□■	1SFA893003R▽00▼	2.30
37	45	59	76	PSS44/76-690□■	1SFA893004R▽00▼	2.30
45	55	75	85	PSS50/85-690□■	1SFA893005R▽00▼	3.60
55	75	90	105	PSS60/105-690□■	1SFA893006R▽00▼	3.80
59	80	110	124	PSS72/124-690□■	1SFA893007R▽00▼	3.80
75	90	132	147	PSS85/147-690□■	1SFA893008R▽00▼	8.60
90	110	160	181	PSS105/181-690□■	1SFA893009R▽00▼	10.40
132	160	220	245	PSS142/245-690□■	1SFA893010R▽00▼	10.40
160	200	257	300	PSS175/300-690□■	1SFA893011R▽00▼	20.50
220	295	400	430	PSS250/430-690□■	1SFA893013R▽00▼	22.00
257	355	500	515	PSS300/515-690□■	1SFA893014R▽00▼	22.00



1SFC132303F0002

PSS85/147-500 ... 142/245-500
PSS85/147-690 ... 142/245-690



1SFC132304F0002

PSS175/300-500 ... 300/515-500
PSS175/300-690 ... 300/515-690

*) Add code letter in type for:
Rated control supply voltage, U_c
□ F = 110-120 V, 50/60 Hz
L = 220-240 V, 50/60 Hz
Fault signal relay
■ no code letter = NO
C = NC

**) Add code number in order code for:
Fault signal relay
▽ 1 = NO
2 = NC
Rated control supply voltage, U_c
▼ 1 = 110-120 V, 50/60 Hz
2 = 220-240 V, 50/60 Hz

PSS – The flexible range

Heavy-duty starts, class 30, in-line, ordering details



PSS18/30 ... PSS300/515

Rated operational voltage U_e , 208-500 V

Motor power				IEC Max rated operational current I_e A	Type*)	Order code**)	Weight kg 1 piece
400 V P_e kW	500 V P_e kW	690 V P_e kW					
5.5	7.5	-	13	PSS18/30-500□■	1SFA892001R▽00▼	2.30	
7.5	11	-	18	PSS30/52-500□■	1SFA892002R▽00▼	2.30	
15	18.5	-	30	PSS37/64-500□■	1SFA892003R▽00▼	2.30	
18.5	22	-	37	PSS44/76-500□■	1SFA892004R▽00▼	2.30	
22	25	-	44	PSS50/85-500□■	1SFA892005R▽00▼	3.60	
25	30	-	50	PSS60/105-500□■	1SFA892006R▽00▼	3.80	
30	37	-	60	PSS72/124-500□■	1SFA892007R▽00▼	3.80	
37	45	-	72	PSS85/147-500□■	1SFA892008R▽00▼	8.60	
45	55	-	85	PSS105/181-500□■	1SFA892009R▽00▼	10.40	
55	75	-	105	PSS142/245-500□■	1SFA892010R▽00▼	10.40	
75	90	-	142	PSS175/300-500□■	1SFA892011R▽00▼	20.50	
90	110	-	175	PSS250/430-500□■	1SFA892013R▽00▼	22.00	
132	160	-	250	PSS300/515-500□■	1SFA892014R▽00▼	22.00	



PSS18/30-500 ... 44/76-500



PSS50/85-500 ... 72/124-500
PSS18/30-690 ... 72/124-690



PSS85/147-500 ... 142/245-500
PSS85/147-690 ... 142/245-690



PSS175/300-500 ... 300/515-500
PSS175/300-690 ... 300/515-690

Rated operational voltage U_e , 400-690 V

5.5	7.5	11	13	PSS18/30-690□■	1SFA893001R▽00▼	2.30
7.5	11	15	18	PSS30/52-690□■	1SFA893002R▽00▼	2.30
15	18.5	25	30	PSS37/64-690□■	1SFA893003R▽00▼	2.30
18.5	22	30	37	PSS44/76-690□■	1SFA893004R▽00▼	2.30
22	25	37	44	PSS50/85-690□■	1SFA893005R▽00▼	3.60
25	30	45	50	PSS60/105-690□■	1SFA893006R▽00▼	3.80
30	37	55	60	PSS72/124-690□■	1SFA893007R▽00▼	3.80
37	45	59	72	PSS85/147-690□■	1SFA893008R▽00▼	8.60
45	55	75	85	PSS105/181-690□■	1SFA893009R▽00▼	10.40
55	75	90	105	PSS142/245-690□■	1SFA893010R▽00▼	10.40
75	90	132	142	PSS175/300-690□■	1SFA893011R▽00▼	20.50
90	110	160	175	PSS250/430-690□■	1SFA893013R▽00▼	22.00
132	160	220	250	PSS300/515-690□■	1SFA893014R▽00▼	22.00

*) Add code letter in type for:
Rated control supply voltage, U_c

□ F = 110-120 V, 50/60 Hz
L = 220-240 V, 50/60 Hz

Fault signal relay

■ no code letter = NO
C = NC

**) Add code number in order code for:
Fault signal relay

▽ 1 = NO
2 = NC

Rated control supply voltage, U_c

▼ 1 = 110-120 V, 50/60 Hz
2 = 220-240 V, 50/60 Hz

PSS – The flexible range

Heavy-duty starts, class 30, inside delta, ordering details

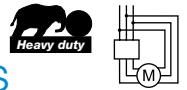

PSS18/30 ... PSS300/515

Rated operational voltage U_s , 208-500 V

Motor power				IEC Max rated operational current I_e A	Type*)	Order code**)	Weight kg 1 piece
400 V P_e kW	500 V P_e kW	690 V P_e kW					
11	15	-	22	PSS18/30-500□■	1SFA892001R▽00▼	2.30	
15	18.5	-	30	PSS30/52-500□■	1SFA892002R▽00▼	2.30	
25	30	-	52	PSS37/64-500□■	1SFA892003R▽00▼	2.30	
30	37	-	64	PSS44/76-500□■	1SFA892004R▽00▼	2.30	
37	45	-	76	PSS50/85-500□■	1SFA892005R▽00▼	3.60	
45	55	-	85	PSS60/105-500□■	1SFA892006R▽00▼	3.80	
55	75	-	105	PSS72/124-500□■	1SFA892007R▽00▼	3.80	
59	80	-	124	PSS85/147-500□■	1SFA892008R▽00▼	8.60	
75	90	-	147	PSS105/181-500□■	1SFA892009R▽00▼	10.40	
90	110	-	181	PSS142/245-500□■	1SFA892010R▽00▼	10.40	
132	160	-	245	PSS175/300-500□■	1SFA892011R▽00▼	20.50	
160	200	-	300	PSS250/430-500□■	1SFA892013R▽00▼	22.00	
220	295	-	430	PSS300/515-500□■	1SFA892014R▽00▼	22.00	



PSS18/30-500 ... 44/76-500



PSS50/85-500 ... 72/124-500
PSS18/30-690 ... 72/124-690



PSS85/147-500 ... 142/245-500
PSS85/147-690 ... 142/245-690



PSS175/300-500 ... 300/515-500
PSS175/300-690 ... 300/515-690

Rated operational voltage U_s , 400-690 V

11	15	18.5	22	PSS18/30-690□■	1SFA893001R▽00▼	2.30
15	18.5	25	30	PSS30/52-690□■	1SFA893002R▽00▼	2.30
25	30	45	52	PSS37/64-690□■	1SFA893003R▽00▼	2.30
30	37	55	64	PSS44/76-690□■	1SFA893004R▽00▼	2.30
37	45	59	76	PSS50/85-690□■	1SFA893005R▽00▼	3.60
45	55	75	85	PSS60/105-690□■	1SFA893006R▽00▼	3.80
55	75	90	105	PSS72/124-690□■	1SFA893007R▽00▼	3.80
59	80	110	124	PSS85/147-690□■	1SFA893008R▽00▼	8.60
75	90	132	147	PSS105/181-690□■	1SFA893009R▽00▼	10.40
90	110	160	181	PSS142/245-690□■	1SFA893010R▽00▼	10.40
132	160	220	245	PSS175/300-690□■	1SFA893011R▽00▼	20.50
160	200	257	300	PSS250/430-690□■	1SFA893013R▽00▼	22.00
220	295	400	430	PSS300/515-690□■	1SFA893014R▽00▼	22.00

*) Add code letter in type for:
Rated control supply voltage, U_s
□ F = 110-120 V, 50/60 Hz
L = 220-240 V, 50/60 Hz
Fault signal relay
■ no code letter = NO
C = NC

**) Add code number in order code for:
Fault signal relay
▽ 1 = NO
2 = NC
Rated control supply voltage, U_s
▼ 1 = 110-120 V, 50/60 Hz
2 = 220-240 V, 50/60 Hz

PSS – The flexible range

Accessories

Current transformer for current limit function

To be connected to terminals 11 and 12 on the softstarter.

The setting range (1.5 – 4) corresponds to a multiple of the transformer ratio.

Technical data below shows transformer ratio and number of turns for the primary winding.

You can also use your own current transformer with corresponding transformer ratio and with minimum 1 VA.

For softstarter type	Transformer ratio, Number of turns	Type	Order code	Pack ^{ing} piece	Weight kg 1 piece
PSS18/30	30/1–1 turn	PSCT-30	1SFA899001R1030	1	0.200
PSS30/52	40/1–1 turn	PSCT-40	1SFA899001R1040	1	0.200
PSS37/64	50/1–1 turn	PSCT-50	1SFA899001R1050	1	0.200
PSS44/76	60/1–1 turn	PSCT-60	1SFA899001R1060	1	0.200
PSS50/85	75/1–1 turn	PSCT-75	1SFA899001R1075	1	0.200
PSS60/105	75/1–1 turn	PSCT-75	1SFA899001R1075	1	0.200
PSS72/124	100/1–1 turn	PSCT-100	1SFA899001R1100	1	0.150
PSS85/147	125/1–1 turn	PSCT-125	1SFA899001R1125	1	0.150
PSS105/181	150/1–1 turn	PSCT-150	1SFA899001R1150	1	0.150
PSS142/245	200/1–1 turn	PSCT-200	1SFA899001R1200	1	0.230
PSS175/300	250/1–1 turn	PSCT-250	1SFA899001R1250	1	0.230
PSS250/430	400/1–1 turn	PSCT-400	1SFA899001R1400	1	0.200
PSS300/515	400/1–1 turn	PSCT-400	1SFA899001R1400	1	0.200



PSCT-30

1SFC132225F0001



1SFT198099-095C2



SB8054C2

LZ...



1SFT198099-011C1



PSLW-44

1SFC132012P0201

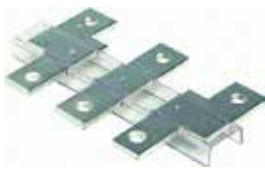

LW...

1SFT198000-011C3

Cable connectors for Cu cables

For softstarter type	Wire range mm ²	Tightening torque max. Nm	Type	Order code	Pack ^{ing} piece	Weight kg 1 piece
PSS85/147 ... 142/245	6-185	16	–	1SDA023354R0001	3	0.200
PSS85/147 ... 142/245	2 x (50-120)	16	LZ185-2C/120	1SFN074709R1000	3	0.300
PSS175/300 ... 300/515	16-240	25	–	1SDA023368R0001	3	0.400

Cable connectors for Al and Cu cables

For softstarter type	Wire range mm ²	Tightening torque max. Nm	Type	Order code	Pack ^{ing} piece	Weight kg 1 piece
PSS85/147 ... 142/245	35-95	13.5	–	1SDA023356R0001	3	0.100
PSS85/147 ... 142/245	25-150	31	–	1SDA023357R0001	3	0.100
PSS175/300 ... 300/515	120-240	43	–	1SDA023370R0001	3	0.100

Terminal enlargements

For softstarter type	Wire range mm ²	Type	Order code	Pack ^{ing} piece	Weight kg 1 piece
PSS18/30-500 ... 44/76-500	1x6 ... 35 2x6 ... 16	PSLW-44	1SFA899002R1044	1	0.100
PSS50/85-500 ... 72/124-500	1x10 ... 50	PSLW-72	1SFA899002R1072	1	0.150
PSS18/30-690 ... 72/124-690	2x10 ... 25				

For softstarter type	Dimensions hole ø mm ²	bar mm	Type	Order code	Pack ^{ing} piece	Weight kg 1 piece
PSS85/147 ... 142/245	10.5	17.5 x 5	LW185	1SFN074707R1000	1	0.250
PSS175/300 ... 300/515	10.5	20 x 5	LW300	1SFN075107R1000	1	0.450

Terminal nut washer

For softstarter type	Req. qty	Type	Order code	Pack ^{ing} piece	Weight kg 1 piece
PSS85/147 ... 142/245	2	LE185	1SFN074716R1000	2	0.200
PSS175/300 ... 300/515	2	LE300	1SFN075116R1000	2	0.300



LE185

1SFC132321F0001

Terminal shrouds

For softstarter type	Suitable for	Req. qty	Type	Order code	Pack ^{ing} piece	Weight kg 1 piece
PSS85/147 ... 142/245	Cable connectors	2	LT185-AC	1SFN124701R1000	2	0.050
PSS85/147 ... 142/245	Compression lugs	2	LT185-AL	1SFN124703R1000	2	0.220
PSS175/300 ... 300/515	Cable connectors	2	LT300-AC	1SFN125101R1000	2	0.070
PSS175/300 ... 300/515	Compression lugs	2	LT300-AL	1SFN125103R1000	2	0.280



LT ... -AC



LT ... -AL

1SFT198099-019C3

1SFT198099-125

PSS – The flexible range

Technical data

Rated insulation voltage U_i	690 V		
Rated operational voltage U_e	208 ... 500 V AC, 400 ... 690 V AC + 10%/-15%, 50/60 Hz \pm 5%		
Rated control supply voltage U_s	110 ... 120 V or 220 ... 240 V +10%/-15%, 50/60 Hz \pm 5%		
Rated control circuit voltage U_c	Internal 24 V DC		
Starting capacity at I_e	4 x I_e for 10 sec.		
Number of starts per hour	30 ¹⁾		
Overload capability	overload class 10		
Service factor	PSS18/30 ... 250/430	PSS300/515	
	115%	110%	
Ambient temperature	during operation -25 °C to +60 °C ²⁾		
	during storage -40 °C to +70 °C		
Maximum altitude	4000 m ³⁾		
Degree of protection	PSS18/30-500 ... 44/76-500	PSS50/85-500 ... 72/124-500	PSS85/147-500 ... 300/515-500
main circuit	IP20	IP10	IP00
	PSS18/30-690 ... 72/124-690		PSS85/147-690 ... 300/515-690
	IP10		IP00
supply and control circuit	PSS18/30 ... PSS300/515		
	IP20		
Signal relays	by-pass signal Yes		
	fault signal Yes (NO or NC)		
	rated operational voltage, U_e 250 V AC/24 V DC		
	rated thermal current I_e 5A		
	rated operational current I_e at AC-15 ($U_e=250$ V) 1.5 A		
Signaling indication LED	ready to start/On green		
	completed start ramp/T.O.R green		
	general fault red		
	external fault red		
Settings	ramp time during start 1-30 sec		
	ramp time during stop 0-30 sec		
	initial voltage during start 30-70%		
	current limit function x CT-ratio 1.5 ... 4 ⁴⁾		
	switch for in-line/inside delta Yes		
¹⁾ Valid for 50% on time and 50% off time. If other data is required, contact your sales office.			
²⁾ Above 40 °C up to max. 60 °C reduce the rated current with 0.8% per °C.			
³⁾ When used at high altitudes above 1000 meters up to 4000 meters you need to derate the rated current using the following formula. [% of I_e = $100 - \frac{x - 1000}{150}$] x = actual altitude for the softstarter			
⁴⁾ Only if current transformer is connected (accessory).			

PSS – The flexible range

Technical data

Cross section of connection cables

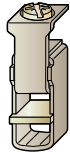
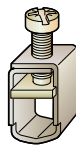
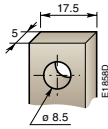
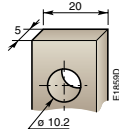
		Type of softstarter PSS18/30-500 ... PSS44/76-500		PSS50/85-500 ... PSS72/124-500, PSS18/30-690 ... PSS72/124-690		PSS85/147 ... PSS142/245		PSS175/300 ... PSS300/515	
Main circuit									
Connection clamp									
									
Solid/stranded	1 x mm ²	2.5-16		6-50					See accessories
Solid/stranded	2 x mm ²	2.5-16		6-25					See accessories
Tightening torque (recommended)	Nm	2.6		4.5					See accessories
Connection bar									
Width and thickness	mm	-		-					
Hole diameter	mm	-		-		8.5		10.2	
Tightening torque (recommended)	Nm	-		-		18		28	
Supply and control circuit									
Connection clamp									
Solid/stranded	1 x mm ²	2.5		2.5		2.5			2.5
Solid/stranded	2 x mm ²	-		-		-			-
Tightening torque (recommended)	Nm	0.5		0.5		0.5			0.5

Fuse ratings and power losses

For softstarter	Recommended ABB's overload protection		Max power loss at rated I _e		Max fuse rating - main circuit ^{1) 3)} Bussmann fuses, DIN43 620 (knife)			Power requirements of supply VA
	Type	Current range A	without by-pass ²⁾ W	with external by-pass W	A	Type	size	
PSS18/30	TF42DU	7.6-18	65	13.5	50	170M1564	000	9
PSS30/52	TF42DU	7.6-30	100	14.6	80	170M1566	000	9
PSS37/64	TF42DU	7.6-37	120	17.5	125	170M1568	000	9
PSS44/76	TA75DU	18-44	142	17.5	160	170M1569	000	9
PSS50/85	TA75DU	18-50	160	20.5	160	170M1569	000	10
PSS60/105	TA75DU	18-60	190	22	200	170M1570	000	10
PSS72/124	TA75DU	18-72	226	30.5	250	170M1571	000	10
PSS85/147	TA110DU	65-85	291	56.5	315	170M1572	000	36
PSS105/181	TA110DU	65-105	351	61	400	170M3819	1*	36
PSS142/245	TA200DU	66-142	462	63	450	170M5809	2	36
PSS175/300	TA200DU	66-175	590	117	500	170M5810	2	65
PSS250/430	TA450DU	130-250	815	117	700	170M5813	2	65
PSS300/515	TA450DU	130-300	965	140	900	170M6813	3	65

¹⁾ For the supply circuit 6 A delayed, for MCB use C characteristics.

²⁾ Calculated power loss at operational current (I_{op}) without by-pass.

P_{tot} = 3 x I_{op} + VA value

Example: PSS 60/105 running at 52 A

P_{tot} = 3 x 52 + 10 = 166W

³⁾ Max fuse rating independent if in-line or inside delta connection. In inside delta connections of PSS, the fuses can be placed outside of the delta.

PSS – The flexible range

UL ratings

3-phase motor rating – in-line

Softstarters		Motor power P (hp) and full load current FLA (A)			
Type	max. FLA A	U _e 200 V/208 V hp	U _e 220 V/240 V hp	U _e 440 V/480 V hp	U _e 550 V/600 V hp
PSS18/30	18	5	5	10	15
PSS30/52	28	7.5	10	20	25
PSS37/64	34	10	10	25	30
PSS44/76	40	10	10	30	30
PSS50/85	47	15	15	30	40
PSS60/105	56	15	20	40	50
PSS72/124	67	20	20	50	60
PSS85/147	85	25	30	60	75
PSS105/181	105	30	40	75	100
PSS142/245	125	40	40	100	125
PSS175/300	156	50	60	125	150
PSS250/430	225	75	75	150	200
PSS300/515	248	75	100	200	250

3-phase motor rating – inside delta

Softstarters		Motor power P (hp) and full load current FLA (A)			
Type	Max. FLA A	U _e 200 V/208 V hp	U _e 220 V/240 V hp	U _e 440 V/480 V hp	U _e 550 V/600 V hp
PSS18/30	30	7.5	10	20	25
PSS30/52	48	15	15	30	40
PSS37/64	58	20	20	40	50
PSS44/76	69	20	25	50	60
PSS50/85	81	25	30	60	75
PSS60/105	96	30	30	75	75
PSS72/124	116	40	40	75	100
PSS85/147	147	50	50	100	150
PSS105/181	181	60	60	150	150
PSS142/245	215	75	75	150	200
PSS175/300	270	75	100	200	250
PSS250/430	389	125	150	300	400
PSS300/515	429	150	150	350	400

PSE – The efficient range

Description



Product description

- Wide rated operational voltage 208–600 V AC
- Wide rated control supply voltage 100–250 V, 50/60 Hz
- Rated operational current 18 to 370 A
- Wide ambient temperature range, -25 to +60 °C
- Coated circuit boards for reliable operation in harsh environment
- Built-in by-pass on all sizes, saving energy and reducing installation time
- User friendly HMI with illuminated language neutral display and four button keypad
- Optional external keypad, IP66
- Torque control for excellent control of pumps
- Current limit, adjustable between $1.5-7 \times I_n$
- Motor overload protection with classes 10A, 10, 20 and 30
- Motor underload protection to detect pumps running dry
- Locked rotor protection, detecting jammed pumps
- Kick start to start jammed pumps or conveyor belts
- Analog output showing operational current, 4–20 mA
- Optional fieldbus communication using Profibus, Modbus, Devicenet or CANopen
- Sophisticated algorithm eliminating the DC-component and thereby providing excellent starting performance

The PSE softstarter range is the world's first compact softstarter range with torque control. This makes the PSE range an ideal choice for pumping applications where water hammering normally is a big problem. The compactness and advanced functionality of the PSE means that it is also a very efficient solution for other applications such as compressors and fans.

Torque control

The most important function when stopping pumps is torque control. Since the PSE softstarter is optimized for controlling pumps, this feature is a must.

Built-in by-pass for energy saving

Using by-pass after reaching full voltage will greatly reduce the power loss and thereby save energy. In the PSE softstarter range, the by-pass is built-in on all sizes which will give the most compact starting solution and reduce the need for wiring during installation.

Coated circuit boards

All circuit boards in the new PSE softstarter have a protective coating to ensure a reliable operation even in tough environments like wastewater plants, where corrosive gases and acids may exist.

Motor protection

The PSE softstarter is equipped with built-in electronic overload protection, preventing the motor from overheating. Since no additional overload device is needed, our efficient design saves both space, installation time, and ultimately money.

Analog output

The analog output terminals can be connected to an analog current meter to show the current during operation. This eliminates the need of an additional current transformer. The analog output signal can also be used as an analog input to a PLC.

Display and keypad

The setup of the PSE softstarter is done using the four button keypad and the illuminated display, providing a quick and easy setup. While operating, the display will also provide important status information such as current and voltage.

External keypad

As an option the PSE softstarter can be equipped with an external keypad for easy setup and monitoring of the unit without opening the enclosure door. The keypad can also be used to copy parameters between different softstarters.

PSE – The efficient range

Description

The PSE softstarter can be selected according to the rated motor power in normal duty applications like pumps, compressors, elevators, escalators, short conveyor belts and bow thrusters. See page 30.

For heavy-duty applications like centrifugal fans, crushers, mixers, mills, stirrers and long conveyor belts, select a softstarter from page 31.



Settings

- Green ready LED
 - Flashing - Supply available
 - Steady - Main available
- Green run LED
 - Flashing - Ramping up/down
 - Steady - TOR
- Yellow protection LED
- Red fault LED
- Back-lit display
- User friendly keypad
Similar as for PST(B)
- Four digits showing values and messages
- Icon's showing functions.
Language neutral



External keypad with same design as the fixed HMI

PSE – The efficient range

Overview



PSE18 ... PSE105

Normal start
In-line connected

(400 V) kW
IEC, max. A
(440-480 V) hp
UL, max FLA

Softstarter, type								
PSE18	PSE25	PSE30	PSE37	PSE45	PSE60	PSE72	PSE85	PSE105
7.5	11	15	18.5	22	30	37	45	55
18	25	30	37	45	60	72	85	106
10	15	20	25	30	40	50	60	75
18	25	28	34	42	60	68	80	104

400 V, 40 °C

Using MCCB only, type 1
coordination will be achieved

MCCB (35 kA), type								
T2N160								T3N250
MCCB (50 kA), type								
T2S160								T3S250

To achieve type 2 coordina-
tion, semi-conductor fuses
must be used

Fuse protection (85 kA), Semiconductor fuses, Bussmann, type								
170M1563	170M1564	170M1566	170M1567	170M1568	170M1569	170M1571	170M1572	170M3819

Suitable switch fuse for re-
commended semi-conductor
fuses

Switch fuse, type							
OS32GD03P		OS63GD03P		OS125GD03P		OS250D03P	

The line contactor is not
required for the softstarter
itself but often used to open
if OL trips

Line contactor, type								
AF26	AF30	AF38	A50	A63	A75	A95	A110	

Overload protection is used
to protect the motor from
over heating

Electronic overload relay, type								
Built-in								

The by-pass will reduce the
power loss of the softstarter.

By-pass, type								
Built-in								

A50 ... A300 might be replaced by AF50 ... AF300
The table above is an overview of possible combinations of devices.
Complete coordination tables are available at www.abb.com/lowvoltage

PSE – The efficient range

Overview



PSE142 ... PSE170

PSE210 ... PSE370

Normal start
In-line connected
(400 V) kW
IEC, max. A
(440-480 V) hp
UL, max FLA

Softstarter, type					
PSE142	PSE170	PSE210	PSE250	PSE300	PSE370
75	90	110	132	160	200
143	171	210	250	300	370
100	125	150	200	250	300
130	169	192	248	302	361

Using MCCB only, type 1 coordination will be achieved

400 V, 40 °C					
MCCB (35 kA), type					
T3N250		T4N320		T5N400	
MCCB (50 kA), type					
T3S250		T4S320		T5S400	

To achieve type 2 coordination, semi-conductor fuses must be used

Fuse protection (85kA), Semiconductor fuses, Bussmann, type					
170M5809	170M5810	170M5812	170M5813	170M6812	170M6813

Suitable switch fuse for recommended semi-conductor fuses

Switch fuse, type					
OS400D03P			OS630D03P		

The line contactor is not required for the softstarter itself but often used to open if OL trips

Line contactor, type					
A145	A185	A210	A260	A300	AF400

Overload protection is used to protect the motor from over heating

Electronic overload relay, type					
Built-in					

The by-pass will reduce the power loss of the softstarter.

By-pass, type					
Built-in					

How to select the correct size

By using the guide here, you can quickly select a suitable softstarter for the most common applications.

If a more precise selection is required, you can use the softstarter selection tool available at www.abb.com/lowvoltage

Quick guide for selection	
Normal start class 10	Heavy-duty start class 30
Ordering - see page 30	Ordering - see page 31
Typical applications	
<ul style="list-style-type: none"> • Bow thruster • Compressor • Elevator 	<ul style="list-style-type: none"> • Centrifugal pump • Conveyor belt (short) • Escalator • Centrifugal fan • Crusher • Mixer • Conveyor belt (long) • Mill • Stirrer
<p>! If more than 10 starts/h Select <u>one</u> size larger than the standard selection</p>	

PSE – The efficient range

Normal starts, class 10, in-line, ordering details



1SFC132311F0001

PSE18 ... PSE105



1SFC132312F0002

PSE142 ... PSE170



1SFC132310F0002

PSE210 ... PSE370

PSE18 ... PSE370

Rated operational voltage, U_e , 208-600 V AC

Rated control supply voltage, U_c , 100-250 V AC, 50/60 Hz

Motor power

230 V P_e kW	400 V P_e kW	500 V P_e kW	IEC Max rated operational current I_e A	Type	Order code	Weight kg 1 piece
4	7.5	11	18	PSE18-600-70	1SFA897101R7000	2.4
5.5	11	15	25	PSE25-600-70	1SFA897102R7000	2.4
7.5	15	18.5	30	PSE30-600-70	1SFA897103R7000	2.4
9	18.5	22	37	PSE37-600-70	1SFA897104R7000	2.4
11	22	30	45	PSE45-600-70	1SFA897105R7000	2.4
15	30	37	60	PSE60-600-70	1SFA897106R7000	2.4
18.5	37	45	72	PSE72-600-70	1SFA897107R7000	2.5
22	45	55	85	PSE85-600-70	1SFA897108R7000	2.5
30	55	75	106	PSE105-600-70	1SFA897109R7000	2.5
40	75	90	143	PSE142-600-70	1SFA897110R7000	4.2
45	90	110	171	PSE170-600-70	1SFA897111R7000	4.2
59	110	132	210	PSE210-600-70	1SFA897112R7000	12.4
75	132	160	250	PSE250-600-70	1SFA897113R7000	13.9
90	160	200	300	PSE300-600-70	1SFA897114R7000	13.9
110	200	250	370	PSE370-600-70	1SFA897115R7000	13.9

PSE – The efficient range

Heavy-duty starts, class 30, in-line, ordering details



PSE18 ... PSE370

Rated operational voltage, U_o , 208-600 V AC

Rated control supply voltage, U_s , 100 - 250 V AC, 50/60 Hz

Motor power

230 V P kW	400 V P kW	500 V P kW	IEC Max rated operational current I_e A	Type	Order code	Weight kg 1 piece
3	5.5	7.5	12	PSE18-600-70	1SFA897101R7000	2.4
4	7.5	11	18	PSE25-600-70	1SFA897102R7000	2.4
5.5	11	15	25	PSE30-600-70	1SFA897103R7000	2.4
7.5	15	18.5	30	PSE37-600-70	1SFA897104R7000	2.4
9	18.5	22	37	PSE45-600-70	1SFA897105R7000	2.4
11	22	30	45	PSE60-600-70	1SFA897106R7000	2.4
15	30	37	60	PSE72-600-70	1SFA897107R7000	2.5
18.5	37	45	72	PSE85-600-70	1SFA897108R7000	2.5
22	45	55	85	PSE105-600-70	1SFA897109R7000	2.5
30	55	75	106	PSE142-600-70	1SFA897110R7000	4.2
40	75	90	143	PSE170-600-70	1SFA897111R7000	4.2
45	90	110	171	PSE210-600-70	1SFA897112R7000	12.4
59	110	132	210	PSE250-600-70	1SFA897113R7000	13.9
75	132	160	250	PSE300-600-70	1SFA897114R7000	13.9
90	160	200	300	PSE370-600-70	1SFA897115R7000	13.9



PSE18 ... PSE105



PSE142 ... PSE170



PSE210 ... PSE370

PSE – The efficient range

Accessories



1SFT98099-095C2



SB8054C2

LZ...



1SFT98099-011C1

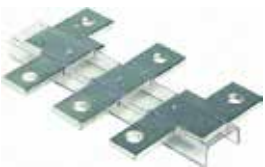

1SFT98000-011C3

LW...



1SFC132321F0002

LE185

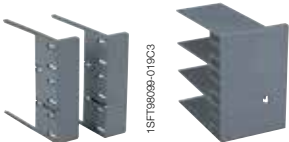

1SFT98099-125

LT ... -AC

LT ... -AL



1SFC132328F0002

PSEEK



1SFC132353F0002

PSECA



1SFC132168F0001

PS-FBPA

Cable connectors for Cu cables

For softstarter type	Wire range mm ²	Tightening torque max. Nm	Type	Order code	Pack ^{ing} piece	Weight kg 1 piece
PSE142 ...170	6-185	16	-	1SDA023354R0001	3	0.200
PSE142 ...170	2 x (50-120)	16	LZ185-2C/120	1SFN074709R1000	3	0.300
PSE210 ... 370	16-240	25	-	1SDA023368R0001	3	0.400

Cable connectors for Al and Cu cables

For softstarter type	Wire range mm ²	Tightening torque max. Nm	Type	Order code	Pack ^{ing} piece	Weight kg 1 piece
PSE142 ...170	35-95	13.5	-	1SDA023356R0001	3	0.100
PSE142 ...170	25-150	31	-	1SDA023357R0001	3	0.100
PSE210 ... 370	120-240	43	-	1SDA023370R0001	3	0.100

Terminal enlargements

For softstarter type	Dimensions hole ø mm ²	bar mm	Type	Order code	Pack ^{ing} piece	Weight kg 1 piece
PSE18...105	6.5	15 x 3	LW110	1SFN074307R1000	1	0.100
PSE142...170	10.5	17.5 x 5	LW185	1SFN074707R1000	1	0.450
PSE210...370	10.5	20 x 5	LW300	1SFN075107R1000	1	1.230

Terminal nut washer

For softstarter type	Req. qty	Type	Order code	Pack ^{ing} piece	Weight kg 1 piece
PSE142...170	2	LE185	1SFN074716R1000	2	0.200
PSE210...370	2	LE300	1SFN075116R1000	2	0.300

Terminal shrouds

For softstarter type	Suitable for	Req. qty	Type	Order code	Pack ^{ing} piece	Weight kg 1 piece
PSE142...170	Cable connectors	2	LT185-AC	1SFN124701R1000	2	0.050
PSE142...170	Compression lugs	2	LT185-AL	1SFN124703R1000	2	0.220
PSE210...370	Cable connectors	2	LT300-AC	1SFN125101R1000	2	0.070
PSE210...370	Compression lugs	2	LT300-AL	1SFN125103R1000	2	0.280

External keypad including a 3m cable

For softstarter type	Type	Order code	Pack ^{ing} piece	Weight kg 1 piece
PSE18...370	PSEEK	1SFA897100R1001	1	-

USB-cable for Service Engineer Tool

For softstarter type	Type	Order code	Pack ^{ing} piece	Weight kg 1 piece
PSE18...370	PSECA	1SFA897201R1001	1	0.130

FieldBusPlug connection accessory

For softstarter type	Type	Order code	Pack ^{ing} piece	Weight kg 1 piece
The same accessory for all sizes	PS-FBPA	1SFA896312R1002	1	0.060

ABB's FieldBusPlug suitable for all sizes. See page 50-53

PSE – The efficient range

Technical data

Rated insulation voltage U_i	600 V	Analog output	
Rated operational voltage U_e	208 ... 600 V +10%/-15%	Output signal reference	4 ... 20 mA
Rated control supply voltage U_s	100 ... 250 V +10%/-15%, 50/60 Hz \pm 5 %	Type of output signal	1 Amp
Rated control circuit voltage U_c	Internal 24 V DC	Scaling	Fixed at $1.2 \times I_e$
Starting capacity at I_e	$4 \times I_e$ for 10 sec.	Control circuit	
Number of starts per hour	10 ¹⁾	Number of inputs	3 (start, stop, reset of faults)
Overload capability,		Signal indication LED's	
Overload class	10	On / Ready	green flashing / steady
Ambient temperature		Run / TOR	green flashing / steady
During operation	-25 ... +60 °C ²⁾	Protection	yellow
During storage	-40 ... +70 °C	Fault	red
Maximum Altitude	4000 m ³⁾	Protections	
Degree of protection		Electronic overload	Yes (Class 10A, 10, 20, 30)
Main circuit	IP00	Locked rotor protection	Yes
Supply and control circuit	IP20	Underload protection	Yes
Main circuit		Field bus connection	
Built-in by-pass	Yes	Connection for ABB FieldBusPlug	Yes (option)
Cooling system - fan cooled (thermostat controlled)	Yes	External keypad	
HMI for settings		Display LCD type	
Display	4 7-segments and icons. Illuminated	Ambient temperature	
Keypad	2 selection keys and 2 navigation keys	during operation	-25 ... +60 °C
Main settings		during storage	-40 ... +70 °C
Setting current	Size dependent	Degree of protection	IP66
Ramp time during start	1-30 sec		
Ramp time during stop	0-30 sec		
Initial/end voltage	30-70%		
Current limit	$1.5-7 \times I_e$		
Torque control for start	Yes / No		
Torque control for stop	Yes / No		
Kick start	Off, 30-100%		
Signal relays			
Number of signal relays	3		
K2	Run signal		
K3	TOR (By-pass) signal		
K1	Event signal		
Rated operational voltage U_{eP}	250 V AC/24 V DC ⁴⁾		
Rated thermal current I_{th}	3 A		
Rated operational current I_e at AC-15 ($U_e = 250$ V)	1.5 A		

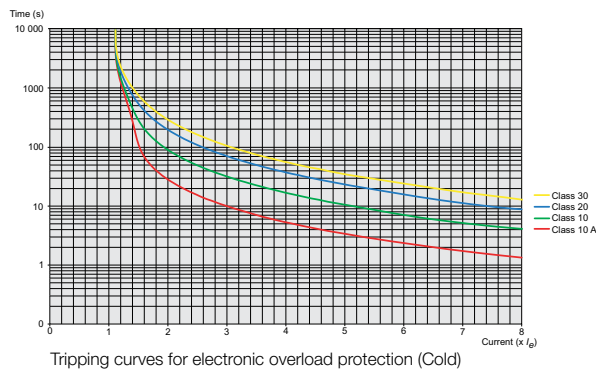

¹⁾ Valid for 50% on time and 50% off time. If other data is required, please contact your sales office

²⁾ Above 40 °C up to max. 60 °C reduce the rated current with 0.6% per °C.

³⁾ When used at high altitudes above 1000 meters up to 4000 meters you need to derate the rated current using the following formula.

[% of $I_e = 100 - \frac{x - 1000}{150}$] x = actual altitude for the softstarter

⁴⁾ A common voltage needs to be used for all 3 signal relays

PSE – The efficient range

Technical data

Cross section of connection cables

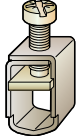
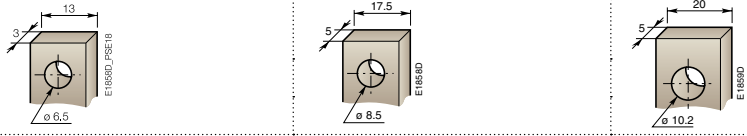
		Type of softstarter PSE18 ... PSE105		PSE142 ... PSE170	PSE210 ... PSE370
Main circuit					
Connection clamp					
					
Solid/stranded	1 x mm ²	2.5–70		See accessories	
Solid/stranded	2 x mm ²	2.5–70		See accessories	
Tightening torque (recommended)	Nm	9		See accessories	
Connection bar					
					
Width and thickness	mm	13		17.5	20
Hole diameter	mm	ø 6.5		ø 8.5	ø 10.2
Tightening torque (recommended)	Nm	9		18	28
Supply and control circuit					
Connection clamp					
Solid/stranded	1 x mm ²	2.5		2.5	2.5
Solid/stranded	2 x mm ²	1.5		1.5	1.5
Tightening torque (recommended)	Nm	0.5		0.5	0.5

Fuse ratings and power losses

For softstarter	Recommended ABB's overload protection		Max power loss at rated I _e (Internal by-pass)	Max fuse rating - main circuit ¹⁾			Power requirements supply circuit Holding (VA) / Pull-in (VA)
	Type	Current range		Bussmann fuses, DIN43 620 (Knife)		Size	
Type	Type	A	W	A	Type	Size	
PSE							
PSE18	Integrated	5.4-18	0.2	40	170M1563	000	16/19.9
PSE25	Integrated	7.5-25	0.4	50	170M1564	000	16/19.9
PSE30	Integrated	9-30	0.5	80	170M1566	000	16/19.9
PSE37	Integrated	11.1-37	0.8	100	170M1567	000	16/19.9
PSE45	Integrated	13.5-45	1.2	125	170M1568	000	16/19.9
PSE60	Integrated	18-60	2.2	160	170M1569	000	16/19.9
PSE72	Integrated	21.6-72	3.1	250	170M1571	000	16/19.9
PSE85	Integrated	25.5-85	4.3	315	170M1572	000	16/19.9
PSE105	Integrated	31.8-106	6.6	400	170M3819	1*	16/19.9
PSE142	Integrated	42.9-143	12.1	450	170M5809	2	16/31
PSE170	Integrated	51.3-171	17.6	500	170M5810	2	16/31
PSE210	Integrated	63-210	8.8	630	170M5812	2	30/700
PSE250	Integrated	75-250	12.5	700	170M5813	2	30/700
PSE300	Integrated	90.6-302	18	800	170M6812	3	30/700
PSE370	Integrated	111-370	27.4	900	170M6813	3	30/700

¹⁾For the supply circuit 6 A delayed, for MCB use C characteristics.

PSE – The efficient range

UL ratings

3-phase motor rating – in-line

Softstarters	Motor power P (hp) and full load current FLA (A)				
	Max FLA A	U _e 200 V/208 V hp	U _e 220 V/240 V hp	U _e 440 V/480 V hp	U _e 550 V/600 V hp
Type					
PSE18	18	5	5	10	15
PSE25	25	7.5	7.5	15	20
PSE30	28	7.5	10	20	25
PSE37	34	10	10	25	30
PSE45	42	10	15	30	40
PSE60	60	20	20	40	50
PSE72	68	20	25	50	60
PSE85	80	25	30	60	75
PSE105	104	30	40	75	100
PSE142	130	40	50	100	125
PSE170	169	60	60	125	150
PSE210	192	60	75	150	200
PSE250	248	75	100	200	250
PSE300	302	100	100	250	300
PSE370	361	125	150	300	350



PST(B) – The advanced range

Description



Description

- Wide rated operational voltage 208–690 V AC
- Wide rated control supply voltage 100–250 V, 50/60 Hz
- Rated operational current 30 to 1050 A (Up to 1810 A inside delta)
- Both in line and inside delta connection
- Coated circuit boards available, for reliable operation even in harsh environments
- Full text display in 14 languages and 4 button keypad for easy setup and operation
- Optional external keypad, IP66
- Built-in by-pass contactor on PSTB (from 370 A) for energy saving and easy installation
- Prepared for external by-pass on PST (30–300 A)
- Torque control for excellent control of pumps
- Current limit, adjustable between $1.5-7 \times I_g$
- Fieldbus communication using Profibus, Modbus, Devicenet or CANopen
- Dual motor overload protection with classes 10A, 10, 20 and 30
- Adaptable motor underload protection to detect pumps running dry
- Adaptable locked rotor protection to detect jammed pumps
- PTC protection to protect the motor from overheating
- Adjustable kick start to start jammed pumps
- Programmable output signal relays
- Programmable pre-warning functions
- Event log with time stamp
- Analog output showing current, voltage, power factor etc. 0–10 V, 0–20 mA, 4–20 mA

The PST(B) softstarter is the most advanced softstarter in the ABB product portfolio. It is equipped with almost all imaginable features making it the ideal choice for most applications.

Torque control

ABB's torque control function is developed together with pump manufacturers to ensure the best possible pump stop, eliminating problems with water hammering and pressure surges.

By-pass for energy saving

By-passing the softstarter after reaching full voltage saves energy and reduces heat generation. The PST softstarters are equipped with extra terminals making the connection of an external by-pass contactor easier and allow all protection features to be active during by-pass. The PST(B) comes with ABB's AF contactor already built-in, ensuring a compact starting solution requiring minimal wiring.

Advanced protections

The PST(B) softstarters are equipped with almost all protections imaginable for protecting the motor, the softstarter and the application. To offer more flexibility, all protections can be tailored to your specific needs.

Flexible analog output

The analog output terminals can be connected to an analog current meter to show the current during operation. This eliminates the need of an additional current transformer. The analog output signal can also be used as an analog input to a PLC.

Fieldbus communication

ABB's FieldBusPlug supports most common fieldbus protocols. Using a PLC simplifies setup of the softstarter and gives status information in real-time as well as control of the softstarter.

Display and keypad

The PST(B) softstarter is equipped with a full text display showing all information in clear text in your own language. To make it even easier to setup, there are standard settings for many common applications, such as centrifugal pump. Selecting this will automatically provide all required settings including torque control when stopping.

External keypad

As an option, the PST(B) softstarter can be equipped with an external keypad for easy setup and monitoring of the unit without opening the enclosure door. The keypad can also be used to copy parameters between different softstarters.

PST(B) – The advanced range

Description

The PST softstarter can be selected according to the rated motor power in normal duty applications like pumps, compressors, elevators, escalators, short conveyor belts and bow thrusters. See page 40–41, For heavy-duty applications like centrifugal fans, crushers, mixers, mills, stirrers and long conveyor belts, select a softstarter from page 42–43.

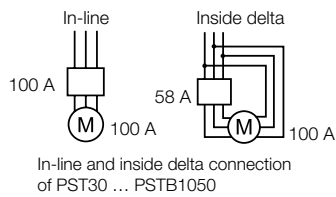

Settings

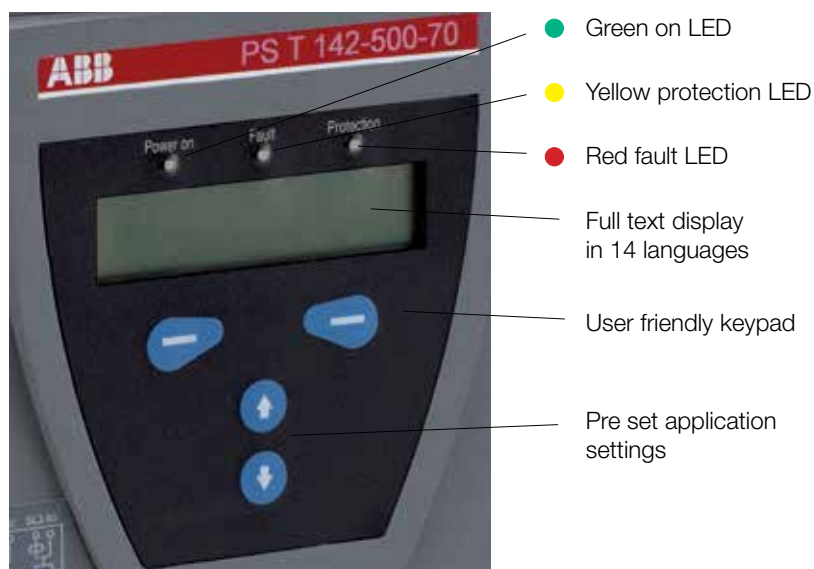

External keypad with same design as the fixed HMI

PST(B) – The advanced range

Overview



PST30 ... PST72



PST85 ... PST142

Normal start
In-line connected

(400 V) kW

IEC, max. A

(440-480 V) hp

UL, max FLA

Softstarter, type

	PST30	PST37	PST44	PST50	PST60	PST72	PST85	PST105	PST142
(400 V) kW	15	18.5	22	25	30	37	45	55	75
IEC, max. A	30	37	44	50	60	72	85	105	142
(440-480 V) hp	20	25	30	40	40	50	60	75	100
UL, max FLA	28	34	42	54	60	68	80	104	130

400 V, 40 °C

Using MCCB only, type 1
coordination will be achieved.

MCCB (50 kA), type

	T2S160						T3S250		
--	--------	--	--	--	--	--	--------	--	--

To achieve a type 2 coordination,
semi-conductor fuses
must be used.

Fuse protection (65 kA), Semiconductor fuses, Bussmann, type

	170M1566	170M1568	170M1569	170M1570	170M1571	170M1572	170M3819	170M5809
--	----------	----------	----------	----------	----------	----------	----------	----------

Suitable switch fuse for re-
commended semi-conductor
fuses.

Switch fuse, type

	OS32GD03P	OS63GD03P	OS125GD03P	OS250D03P	OS400D03P
--	-----------	-----------	------------	-----------	-----------

The line contactor is not
required for the softstarter
itself but often used to
open if OL trips

Line contactor, type

	AF30	AF38	A50	A63	A75	A95	A110	A145
--	------	------	-----	-----	-----	-----	------	------

Overload protection is used
to protect the motor from
over heating

Electronic overload relay

	Built-in							
--	----------	--	--	--	--	--	--	--

The by-pass contactor will
reduce the power loss of the
softstarter. All softstarters
can be operated without
by-pass

By-pass contactor, type

	AF16	AF26	AF30	A40	A50	A63	A95
--	------	------	------	-----	-----	-----	-----

A50 ... A300 might be replaced by AF50 ... AF300.

The table above is an overview of possible combinations of devices.

Complete coordination tables are available at www.abb.com/lowvoltage

PST(B) – The advanced range

Overview



PST175 ... PST300



PSTB370 ... PSTB470



PSTB570 ... PSTB1050

Normal start
In-line connected

(400 V) kW
IEC, max. A
(440-480 V) hp
UL, max FLA

Softstarter, type

PST175	PST210	PST250	PST300	PSTB370	PSTB470	PSTB570	PSTB720	PSTB840	PSTB1050
90	110	132	160	200	250	315	400	450	560
175	210	250	300	370	470	570	720	840	1050
125	150	200	250	300	400	500	600	700	900
156	192	248	302	361	480	590	720	840	1062

400 V, 40 °C

Using MCCB only, type 1 coordination will be achieved.

MCCB (50 kA), type

T4S250	T5S400	T5S630	T6S630	T6S800	T7S1250	T7S1600

To achieve a type 2 coordination, semi-conductor fuses must be used.

Fuse protection (65 kA), Semiconductor fuses, Bussmann, type

170M5810	170M5812	170M5813	170M6813	170M5813	170M6813	170M8554	170M6018	170M6020 ²⁾

Suitable switch fuse for recommended semi-conductor fuses.

Switch fuse, type

OS400D03P	OS630D03P	OS400D03P	OS630D03P	OS800D03P	1)

The line contactor is not required for the softstarter itself but often used to open if OL trips

Line contactor, type

A185	A210	A260	A300	AF400	AF580	AF750	AF1350	AF1650

Overload protection is used to protect the motor from over heating

Electronic overload relay, type

Built-in

The by-pass contactor will reduce the power loss of the softstarter. All softstarters can be operated without by-pass

By-pass contactor, type

A145	A210	Built-in

1) Switch fuse not available. Use Bussmann fuse base 170H3004
2) PSTB1050-690-70 has 170M6019

How to select correct size

By using the guide here, you can quickly select a suitable softstarter for the most common applications.

If a more precise selection is required, you can use the softstarter selection tool available at www.abb.com/lowvoltage

Quick guide for selection

Normal start class 10

Ordering - see page 40-41

Heavy-duty start class 30

Ordering - see page 42-43

Typical applications

- Bow thruster
- Compressor
- Elevator
- Centrifugal pump
- Conveyor belt (short)
- Escalator
- Centrifugal fan
- Crusher
- Mixer
- Conveyor belt (long)
- Mill
- Stirrer

If more than 10 starts/h

! Select one size larger than the standard selection

PST(B) – The advanced range

Normal starts, class 10, in-line, ordering details



PST30 ... PSTB1050

Rated operational voltage U_e , 208-600 V

Rated control supply voltage U_s , 100-250 V AC, 50/60 Hz

Motor power

400 V P_e kW	500 V P_e kW	690 V P_e kW	IEC Max rated operational current I_e A	Type ^{*)}	Order code ^{**)}	Weight kg 1 piece
15	18.5	-	30	PST30-600-70□	1SFA894002R70∇0	4.80
18.5	22	-	37	PST37-600-70□	1SFA894003R70∇0	4.80
22	25	-	44	PST44-600-70□	1SFA894004R70∇0	4.80
25	30	-	50	PST50-600-70□	1SFA894005R70∇0	4.80
30	37	-	60	PST60-600-70□	1SFA894006R70∇0	5.00
37	45	-	72	PST72-600-70□	1SFA894007R70∇0	5.00
45	55	-	85	PST85-600-70□	1SFA894008R70∇0	11.20
55	75	-	105	PST105-600-70□	1SFA894009R70∇0	13.00
75	90	-	142	PST142-600-70□	1SFA894010R70∇0	13.00
90	110	-	175	PST175-600-70□	1SFA894011R70∇0	21.50
110	132	-	210	PST210-600-70□	1SFA894012R70∇0	21.50
132	160	-	250	PST250-600-70□	1SFA894013R70∇0	23.00
160	200	-	300	PST300-600-70□	1SFA894014R70∇0	23.00
200	257	-	370	PSTB370-600-70□	1SFA894015R70∇0	31.00
250	315	-	470	PSTB470-600-70□	1SFA894016R70∇0	31.00
315	400	-	570	PSTB570-600-70□	1SFA894017R70∇0	52.00
400	500	-	720	PSTB720-600-70□	1SFA894018R70∇0	55.00
450	600	-	840	PSTB840-600-70□	1SFA894019R70∇0	60.00
560	730	-	1050	PSTB1050-600-70□	1SFA894020R70∇0	60.00

PST30 ... PSTB1050

Rated operational voltage U_e , 400-690 V

Rated control supply voltage U_s , 100-250 V AC, 50/60 Hz

15	18.5	25	30	PST30-690-70□	1SFA895002R70∇0	4.80
18.5	22	30	37	PST37-690-70□	1SFA895003R70∇0	4.80
22	25	37	44	PST44-690-70□	1SFA895004R70∇0	4.80
25	30	45	50	PST50-690-70□	1SFA895005R70∇0	4.80
30	37	55	60	PST60-690-70□	1SFA895006R70∇0	5.00
37	45	59	72	PST72-690-70□	1SFA895007R70∇0	5.00
45	55	75	85	PST85-690-70□	1SFA895008R70∇0	11.20
55	75	90	105	PST105-690-70□	1SFA895009R70∇0	13.00
75	90	132	142	PST142-690-70□	1SFA895010R70∇0	13.00
90	110	160	175	PST175-690-70□	1SFA895011R70∇0	21.50
110	132	184	210	PST210-690-70□	1SFA895012R70∇0	21.50
132	160	220	250	PST250-690-70□	1SFA895013R70∇0	23.00
160	200	257	300	PST300-690-70□	1SFA895014 R70∇0	23.00
200	257	355	370	PSTB370-690-70□	1SFA895015R70∇0	31.00
250	315	450	470	PSTB470-690-70□	1SFA895016R70∇0	31.00
315	400	560	570	PSTB570-690-70□	1SFA895017R70∇0	52.00
400	500	710	720	PSTB720-690-70□	1SFA895018R70∇0	55.00
450	600	800	840	PSTB840-690-70□	1SFA895019R70∇0	60.00
560	730	1000	1050	PSTB1050-690-70□	1SFA895020R70∇0	60.00



PST30 ... PST72

1SFC132305F0002



PST85 ... PST142

1SFC132306F0002



PST175 ... PST300

1SFC132307F0002



PSTB370 ... PSTB470

1SFC132308F0002



PSTB570 ... PSTB1050

1SFC132309F0002

^{*)} Add code letter in type acc. to below:
 No code letter = Normal
 T = Coated PCBs

^{**)} Add code number in order code acc. to below:
 0 = Normal
 2 = Coated PCBs

PST(B) – The advanced range

Normal starts, class 10, inside delta, ordering details

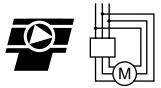

PST30...PSTB1050

Rated operational voltage U_e , 208-600 V

Rated control supply voltage U_s , 100-250 V AC, 50/60 Hz

Motor power

400 V P kW	500 V P kW	690 V P kW	IEC Max rated operational current I_e A	Type*)	Order code**)	Weight kg 1 piece
25	30	-	52	PST30-600-70□	1SFA894002R70▽	4.80
30	37	-	64	PST37-600-70□	1SFA894003R70▽	4.80
37	45	-	76	PST44-600-70□	1SFA894004R70▽	4.80
45	55	-	85	PST50-600-70□	1SFA894005R70▽	4.80
55	75	-	105	PST60-600-70□	1SFA894006R70▽	5.00
59	80	-	124	PST72-600-70□	1SFA894007R70▽	5.00
75	90	-	147	PST85-600-70□	1SFA894008R70▽	11.20
90	110	-	181	PST105-600-70□	1SFA894009R70▽	13.00
132	160	-	245	PST142-600-70□	1SFA894010R70▽	13.00
160	200	-	300	PST175-600-70□	1SFA894011R70▽	21.50
184	250	-	360	PST210-600-70□	1SFA894012R70▽	21.50
220	295	-	430	PST250-600-70□	1SFA894013R70▽	23.00
257	355	-	515	PST300-600-70□	1SFA894014R70▽	23.00
355	450	-	640	PSTB370-600-70□	1SFA894015R70▽	31.00
450	600	-	814	PSTB470-600-70□	1SFA894016R70▽	31.00
540	700	-	987	PSTB570-600-70□	1SFA894017R70▽	52.00
710	880	-	1247	PSTB720-600-70□	1SFA894018R70▽	55.00
800	1000	-	1455	PSTB840-600-70□	1SFA894019R70▽	60.00
1000	1250	-	1810	PSTB1050-600-70□	1SFA894020R70▽	60.00



PST30 ... PST72

1SFC132005F0002



PST85 ... PST142

1SFC132005F0002



PST175 ... PST300

1SFC132005F0002



PSTB370 ... PSTB470

1SFC132005F0002



PSTB570 ... PSTB1050

1SFC132005F0002

PST30 ... PSTB1050

Rated operational voltage U_e , 400-690 V

Rated control supply voltage U_s , 100-250 V AC, 50/60 Hz

25	30	45	52	PST30-690-70□	1SFA895002R70▽	4.80
30	37	55	64	PST37-690-70□	1SFA895003R70▽	4.80
37	45	59	76	PST44-690-70□	1SFA895004R70▽	4.80
45	55	75	85	PST50-690-70□	1SFA895005R70▽	4.80
55	75	90	105	PST60-690-70□	1SFA895006R70▽	5.00
59	80	110	124	PST72-690-70□	1SFA895007R70▽	5.00
75	90	132	147	PST85-690-70□	1SFA895008R70▽	11.20
90	110	160	181	PST105-690-70□	1SFA895009R70▽	13.00
132	160	220	245	PST142-690-70□	1SFA895010R70▽	13.00
160	200	257	300	PST175-690-70□	1SFA895011R70▽	21.50
184	250	315	360	PST210-690-70□	1SFA895012R70▽	21.50
220	295	400	430	PST250-690-70□	1SFA895013R70▽	23.00
257	355	500	515	PST300-690-70□	1SFA895014R70▽	23.00
355	450	600	640	PSTB370-690-70□	1SFA895015R70▽	31.00
450	600	800	814	PSTB470-690-70□	1SFA895016R70▽	31.00
540	700	960	987	PSTB570-690-70□	1SFA895017R70▽	52.00
710	880	1200	1247	PSTB720-690-70□	1SFA895018R70▽	55.00
800	1000	1400	1455	PSTB840-690-70□	1SFA895019R70▽	60.00
1000	1250	1700	1810	PSTB1050-690-70□	1SFA895020R70▽	60.00

*) Add code letter in type acc. to below:

□ No code letter = Normal
T = Coated PCBs

**) Add code number in order code acc. to below:

▽ 0 = Normal
2 = Coated PCBs

PST(B) – The advanced range

Heavy-duty, class 30, in-line, ordering details



PST30...PSTB1050

Rated operational voltage U_o , 208-600 V

Rated control supply voltage U_c , 100-250 V AC, 50/60 Hz

Motor power

400 V P kW	500 V P kW	690 V P kW	IEC Max rated operational current I_o A	Type*)	Order code**)	Weight kg 1 piece
11	15	-	22	PST30-600-70□	1SFA894002R70∇0	4.80
15	18.5	-	30	PST37-600-70□	1SFA894003R70∇0	4.80
18.5	22	-	37	PST44-600-70□	1SFA894004R70∇0	4.80
22	25	-	44	PST50-600-70□	1SFA894005R70∇0	4.80
25	30	-	50	PST60-600-70□	1SFA894006R70∇0	5.00
30	37	-	60	PST72-600-70□	1SFA894007R70∇0	5.00
37	45	-	72	PST85-600-70□	1SFA894008R70∇0	11.20
45	55	-	85	PST105-600-70□	1SFA894009R70∇0	13.00
55	75	-	105	PST142-600-70□	1SFA894010R70∇0	13.00
75	90	-	142	PST175-600-70□	1SFA894011R70∇0	21.50
90	110	-	175	PST210-600-70□	1SFA894012R70∇0	21.50
110	132	-	210	PST250-600-70□	1SFA894013R70∇0	23.00
132	160	-	250	PST300-600-70□	1SFA894014R70∇0	23.00
160	200	-	300	PSTB370-600-70□	1SFA894015R70∇0	31.00
200	257	-	370	PSTB470-600-70□	1SFA894016R70∇0	31.00
250	315	-	470	PSTB570-600-70□	1SFA894017R70∇0	52.00
315	400	-	570	PSTB720-600-70□	1SFA894018R70∇0	55.00
400	500	-	720	PSTB840-600-70□	1SFA894019R70∇0	60.00
450	600	-	840	PSTB1050-600-70□	1SFA894020R70∇0	60.00



PST30 ... PST72

1SFC132305F0002



PST85 ... PST142

1SFC132306F0002



PST175 ... PST300

1SFC132307F0002



PSTB370 ... PSTB470

1SFC132308F0002



PSTB570 ... PSTB1050

1SFC132309F0002

PST30...PSTB1050

Rated operational voltage U_o , 400-690 V

Rated control supply voltage U_c , 100-250 V AC, 50/60 Hz

400 V P kW	500 V P kW	690 V P kW	IEC Max rated operational current I_o A	Type*)	Order code**)	Weight kg 1 piece
11	15	18.5	22	PST30-690-70□	1SFA895002R70∇0	4.80
15	18.5	25	30	PST37-690-70□	1SFA895003R70∇0	4.80
18.5	22	30	37	PST44-690-70□	1SFA895004R70∇0	4.80
22	25	37	44	PST50-690-70□	1SFA895005R70∇0	4.80
25	30	45	50	PST60-690-70□	1SFA895006R70∇0	5.00
30	37	55	60	PST72-690-70□	1SFA895007R70∇0	5.00
37	45	59	72	PST85-690-70□	1SFA895008R70∇0	11.20
45	55	75	85	PST105-690-70□	1SFA895009R70∇0	13.00
55	75	90	105	PST142-690-70□	1SFA895010R70∇0	13.00
75	90	132	142	PST175-690-70□	1SFA895011R70∇0	21.50
90	110	160	175	PST210-690-70□	1SFA895012R70∇0	21.50
110	132	184	210	PST250-690-70□	1SFA895013R70∇0	23.00
132	160	220	250	PST300-690-70□	1SFA895014R70∇0	23.00
160	200	257	300	PSTB370-690-70□	1SFA895015R70∇0	31.00
200	257	355	370	PSTB470-690-70□	1SFA895016R70∇0	31.00
250	315	450	470	PSTB570-690-70□	1SFA895017R70∇0	52.00
315	400	560	570	PSTB720-690-70□	1SFA895018R70∇0	55.00
400	500	710	720	PSTB840-690-70□	1SFA895019R70∇0	60.00
450	600	800	840	PSTB1050-690-70□	1SFA895020R70∇0	60.00

*) Add code letter in type acc. to below:
 No code letter = Normal
 T = Coated PCBs

**) Add code number in order code acc. to below:
 0 = Normal
 2 = Coated PCBs

PST(B) – The advanced range

Heavy-duty, class 30, inside delta, ordering details



PST30...PSTB1050

Rated operational voltage U_e , 208-600 V

Rated control supply voltage U_s , 100-250 V AC, 50/60 Hz

Motor power

400 V P_e kW	500 V P_e kW	690 V P_e kW	IEC Max rated operational current I_e A	Type*)	Order code**)	Weight kg 1 piece
18.5	25	-	42	PST30-600-70□	1SFA894002R70▽	4.80
25	30	-	52	PST37-600-70□	1SFA894003R70▽	4.80
30	37	-	64	PST44-600-70□	1SFA894004R70▽	4.80
37	45	-	76	PST50-600-70□	1SFA894005R70▽	4.80
45	55	-	85	PST60-600-70□	1SFA894006R70▽	5.00
55	75	-	105	PST72-600-70□	1SFA894007R70▽	5.00
59	80	-	124	PST85-600-70□	1SFA894008R70▽	11.20
75	90	-	147	PST105-600-70□	1SFA894009R70▽	13.00
90	110	-	181	PST142-600-70□	1SFA894010R70▽	13.00
132	160	-	245	PST175-600-70□	1SFA894011R70▽	21.50
160	200	-	300	PST210-600-70□	1SFA894012R70▽	21.50
184	250	-	360	PST250-600-70□	1SFA894013R70▽	23.00
220	295	-	430	PST300-600-70□	1SFA894014R70▽	23.00
257	355	-	515	PSTB370-600-70□	1SFA894015R70▽	31.00
355	450	-	640	PSTB470-600-70□	1SFA894016R70▽	31.00
450	600	-	814	PSTB570-600-70□	1SFA894017R70▽	52.00
540	700	-	987	PSTB720-600-70□	1SFA894018R70▽	55.00
710	880	-	1247	PSTB840-600-70□	1SFA894019R70▽	60.00
800	1000	-	1455	PSTB1050-600-70□	1SFA894020R70▽	60.00



PST30 ... PST72

1SFC132305F0002



PST85 ... PST142

1SFC132306F0002



PST175 ... PST300

1SFC132307F0002



PSTB370 ... PSTB470

1SFC132308F0002



PSTB570 ... PSTB1050

1SFC132309F0002

PST30...PSTB1050

Rated operational voltage U_e , 400-690 V

Rated control supply voltage U_s , 100-250 V AC, 50/60 Hz

18.5	25	37	42	PST30-690-70□	1SFA895002R70▽	4.80
25	30	45	52	PST37-690-70□	1SFA895003R70▽	4.80
30	37	55	64	PST44-690-70□	1SFA895004R70▽	4.80
37	45	59	76	PST50-690-70□	1SFA895005R70▽	4.80
45	55	75	85	PST60-690-70□	1SFA895006R70▽	5.00
55	75	90	105	PST72-690-70□	1SFA895007R70▽	5.00
59	80	110	124	PST85-690-70□	1SFA895008R70▽	11.20
75	90	132	147	PST105-690-70□	1SFA895009R70▽	13.00
90	110	160	181	PST142-690-70□	1SFA895010R70▽	13.00
132	160	220	245	PST175-690-70□	1SFA895011R70▽	21.50
160	200	257	300	PST210-690-70□	1SFA895012R70▽	21.50
184	250	315	360	PST250-690-70□	1SFA895013R70▽	23.00
220	295	400	430	PST300-690-70□	1SFA895014R70▽	23.00
257	355	500	515	PSTB370-690-70□	1SFA895015R70▽	31.00
355	450	600	640	PSTB470-690-70□	1SFA895016R70▽	31.00
450	600	800	814	PSTB570-690-70□	1SFA895017R70▽	52.00
540	700	960	987	PSTB720-690-70□	1SFA895018R70▽	55.00
710	880	1200	1247	PSTB840-690-70□	1SFA895019R70▽	60.00
800	1000	1400	1455	PSTB1050-690-70□	1SFA895020R70▽	60.00

*) Add code letter in type acc. to below:

- No code letter = Normal
- T = Coated PCBs

**) Add code number in order code acc. to below:

- ▽ 0 = Normal
- 2 = Coated PCBs

PST(B) – The advanced range

Accessories



1SFT98099-096C2



SB8054C2

LZ...



1SFT98099-011C1



LX...

1SFT98000-012C3

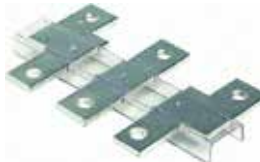

LW...

1SFT98000-011C3



LE185

1SFC13232F0002



LE460

1SFC13232F0002

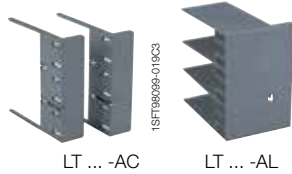

LT ... -AC

LT ... -AL

1SFT98099-019C3

1SFT98099-125



PSTEK

1SFC132113F0002



PSTM-2

1SFC132189F0002

Cable connectors for Cu cables

For PST85...300 you need 9 pieces if also using the terminals B1, B2, B3 for external by-pass contactor.

For softstarter type	Wire range mm ²	Tightening torque max. Nm	Type	Order code	Pack ^{ing} piece	Weight kg 1 piece
PST85 ...142	6-185	16	-	1SDA023354R0001	3	0.200
PST85 ...142	2x(50-120)	16	LZ185-2C/120	1SFN074709R1000	3	0.300
PST175 ...PSTB470	16-240	25	-	1SDA023368R0001	3	0.400

Cable connectors for Al and Cu cables

For PST85...300 you need 9 pieces if also using the terminals B1, B2, B3 for external by-pass contactor.

For softstarter type	Wire range mm ²	Tightening torque max. Nm	Type	Order code	Pack ^{ing} piece	Weight kg 1 piece
PST85 ...142	35-95	13.5	-	1SDA023356R0001	3	0.100
PST85 ...142	25-150	31	-	1SDA023357R0001	3	0.100
PST175 ...300	120-240	43	-	1SDA023370R0001	3	0.100
PSTB370 ...1050	3x(70-185)	43	-	1SDA023384R0001	3	0.265
PSTB370 ...1050	2x(120-240)	31	-	1SDA023380R0001	3	0.110

Terminal extensions

For softstarter type	Dimensions hole ø mm ²	bar mm	Type	Order code	Pack ^{ing} piece	Weight kg 1 piece
PST85...142	8.5	17.5x5	LX185 ¹⁾	1SFN074710R1000	1	0.250
PST175...300	10.5	20x5	LX300 ²⁾	1SFN075110R1000	1	0.350
PSTB370...470	10.5	25x5	LX460	1SFN075710R1000	1	0.500
PSTB570...1050	13	40x6	LX750	1SFN076110R1000	1	0.850

Terminal enlargements

For softstarter type	Dimensions hole ø mm ²	bar mm	Type	Order code	Pack ^{ing} piece	Weight kg 1 piece
PST30...72	6.5	15x3	LW110 ¹⁾	1SFN074307R1000	1	0.100
PST85...142	10.5	17.5x5	LW185 ¹⁾	1SFN074707R1000	1	0.250
PST175...300	10.5	20x5	LW300 ¹⁾	1SFN075107R1000	1	0.450
PSTB370...470	10.5	25x5	LW460	1SFN075707R1000	1	0.730
PSTB570...1050	13	40x6	LW750	1SFN076107R1000	1	1.230

Terminal nut washer

For softstarter type	Req. qty	Type	Order code	Pack ^{ing} piece	Weight kg 1 piece
PST85...142	1	LE185 ¹⁾	1SFN074716R1000	2	0.200
PST175...300	3	LE300 ²⁾	1SFN075116R1000	2	0.300
PSTB370...470	6	LE460	1SFN075716R1000	6	0.600
PSTB570...1050	6	LE750	1SFN076116R1000	6	0.750

Terminal shrouds

For softstarter type	Suitable for	Req. qty	Type	Order code	Pack ^{ing} piece	Weight kg 1 piece
PST85...142	Cable connectors	1 pce and	LT185-AC	1SFN124701R1000	2	0.050
		1 pce	LT460-AC	1SFN125701R1000	2	0.100
PST85...142	Compression lugs	1 pce and	LT185-AL	1SFN124703R1000	2	0.220
		1 pce	LT460-AL	1SFN125703R1000	2	0.800
PST175...300	Cable connectors	3 pcs	LT300-AC ²⁾	1SFN125101R1000	2	0.070
PST175...300	Compression lugs	3 pcs	LT300-AL ²⁾	1SFN125103R1000	2	0.280
PSTB370...470	Cable connectors	2 pcs	LT460-AC	1SFN125701R1000	2	0.100
PSTB370...470	Compression lugs	2 pcs	LT460-AL	1SFN125703R1000	2	0.800
PSTB570...1050	Cable connectors	2 pcs	LT750-AC	1SFN126101R1000	2	0.120
PSTB570...1050	Compression lugs	2 pcs	LT750-AL	1SFN126103R1000	2	0.825

External keypad including a 3 m cable

For softstarter type	Type	Order code	Pack ^{ing} piece	Weight kg 1 piece
PST30...300	PSTEK	1SFA899003R1000	1	0.400
PSTB370...1050				

Marine kit

For softstarter type	Type	Order code	Pack ^{ing} piece	Weight kg 1 piece
PST85...142	PSTM-2	1SFA899004R1000	1	0.240

FieldBusPlug

ABB's FiledBusPlug suitable for all sizes. See page 50-53

¹⁾ Only fits on the motor side

²⁾ Use two sets of the accessories on the line side and one set on the motor side.

PST(B) – The advanced range

Technical data

Rated insulation voltage U_i	690 V		Control circuit	
Rated operational voltage U_e	208...600 V, 400...690 V + 10%/-15% 50/60 Hz \pm 5%		Number of inputs	2 (start, stop)
Rated control supply voltage U_s	100...250 V +10%/-15% 50/60 Hz \pm 5%		Number of additional programmable inputs	2 (Each input can be programmed to be either: Non, Reset, Enable, Jog, DOL-On, Start motor 2, Start motor 3 or FB-Dis)
Rated control circuit voltage U_c	Internal or external 24 V DC			
Starting capacity at I_e	4 x I_e for 10 sec.			
Number of starts per hour	PST30...300	PSTB370...1050		
	30 ¹⁾	10 ¹⁾		
Overload capability			Signalling indication LED	
Overload class	10		Power on	green
Service factor	PST(B)30...840	PSTB1050	Fault	red
	115%	100 %	Protection	yellow
Ambient temperature				
during operation	\pm 0 ... +50 °C ²⁾		Protections	
during storage	-25 ... +70 °C		Electronic overload	Yes (Class 10A, 10, 20, 30)
Maximum altitude	4000 m ³⁾		Dual overload	Yes (separate overload function for start and run)
Degree of protection	PST30...72	PST85...PSTB1050	PTC connection	Yes
main circuit	IP10	IP00	Locked rotor protection	Yes (Level and delay adjustable)
Supply and control circuit	IP20		Underload protection	Yes (Level and delay adjustable)
Main circuit	PST30...300	PSTB370...1050	Phase imbalance	Yes (Level and delay adjustable)
Built-in by-pass contactor	No	Yes	High current (8 x I_e)	Yes
Cooling system - Fan cooled	Yes (thermostat controlled)		Phase reversal protection	Yes
HMI for settings (Human Machine Interface)			Warnings (pre-warning)	
Display	Full text		High current	Yes (Level and delay adjustable)
Languages	English, German, Italian, Dutch, Chinese, Finnish, Swedish, French, Spanish, Russian, Portuguese, Turkish, Polish and Czech		Low current (underload)	Yes (Level and delay adjustable)
Keypad	2 selection keys and 2 navigating keys		Overload trip	Yes (Level and delay adjustable)
Signal relays			Overtemp, thyristor (SCR)	Yes
Number of programmable signal relays	3 (each relay can be programmed to be Run, By-pass or Event signal)		Start of several motors	
K4	Default as Run signal		Possible to setup and start three different motors	Yes (Different parameter sets)
K5	Default as TOR (By-pass) signal		Field bus connection	
K6	Default as Event signal		Connection for ABB FiledBus Plug	Yes
Rated operational voltage, U_e	250 V AC/24 V DC		PTC input	
Rated thermal current I_{th}	5 A		Switch off resistance	2825 ohm \pm 20%
Rated operational current I_e at AC-15 ($U_e=250$ V)	1.5 A		Switch on resistance	1200 ohm \pm 20%
Analog output			External keypad	
Output signal reference	0 ... 10 V, 0 ... 20 mA, 4 ... 20 mA		Display	LCD type
Type of output signal	I Amp, U Volt, P kW, P hp, Q kVAR, S kVA, TmpMot, TmpSCR, cosPhi		Ambient temperature	
			During operation	\pm 0 ... +50 °C
			During storage	-25 ... +70 °C
			Degree of protection	IP66

¹⁾ Valid for 50% on time and 50% off time. If other data is required, contact your sales office.

²⁾ Above 40 °C up to max. 50 °C reduce the rated current with 0.8% per °C.

³⁾ When used at high altitudes above 1000 meters up to 4000 meters you need to derate the rated current using the following formula.

$$\left[\% \text{ of } I_e = 100 - \frac{x-1000}{150} \right] \quad x = \text{actual altitude for the softstarter}$$

PSTB Integrated by-pass ratings

Softstarter	PSTB370	PSTB470	PSTB570	PSTB720	PSTB840	PSTB1050
Integrated contactor	AF300		AF460	AF580		AF750
AC-3 rating (A)	305		460	580		750

PST(B) – The advanced range

Technical data

Major possible settings and the displayed text and the set default values

Description	Text on display (Eng)	Values on display	Default value
Setting current for overload, locked rotor etc.	Setting I _l	9.0 ... 1207 A divided into 19 overlapping ranges.	See table, page 48
Time for start ramp	Start Ramp	1 ... 30 s, 1 ... 120 s (Range depends on Start Range)	10 s
Time for stop ramp	Stop Ramp	0 ... 30 s, 0 ... 120 s (Range depends on Stop Range)	0 s
Initial voltage for start ramp	Init Volt	30 ... 70%	30%
End voltage for stop ramp	End Volt	30 ... 70%	30%
Step down voltage	Step Down	30 ... 100%	100%
Level of the current limit.	Current Lim	1.5 ... 7.0 x I _l	4.0 x I _l
Selection of kick start	Kick Start	Yes, No	No
Level of kick start if selected	Kick Level	50 ... 100%	50 %
Time for kick start if selected	Kick Time	0.1 ... 1.5 s	0.2
Selectable range for start ramp	Start Range	1 ... 30 s, 1 ... 120 s	1 ... 30 s
Selectable range for stop ramp	Stop Range	0 ... 30 s, 0 ... 120 s	0 ... 30 s
Overload protection	Overload	No, Normal, Dual	Normal
Overload class	OL Class	10 A, 10, 20, 30	10
Overload class, dual type, start class	OL Class S	10A, 10, 20, 30	10
Overload class, dual type, run class	OL Class R	10A, 10, 20, 30	10
Type of operation for overload protection	OL Op	Stop-M, Stop-A, Ind	Stop-M
Locked rotor protection	Locked Rotor	Yes, No	No
Trip level for locked rotor protection	Lock R Lev	0.5 ... 8.0 x I _l	4.0 x I _l
Trip time for locked rotor protection	Lock R Time	0.2 ... 10 s	1.0 s
Type of operation for locked rotor protection	Lock R Op	Stop-M, Stop-A, Ind	Stop-M
Underload protection	Underload	Yes, No	No
Trip level for underload protection	Underl Lev	0.4 ... 0.8 x I _l	0.5 x I _l
Trip time for underload protection	Underl Time	1 ... 30 s	10 s
Type of operation for underload protection	Underl Op	Stop-M, Stop-A, Ind	Stop-M
Phase imbalance protection	Phase Imb	Yes, No	No
Trip level for phase imbalance protection	Ph Imb Lev	10 ... 80%	80%
Type of operation for phase imbalance protection	Ph Imb Op	Stop-M, Stop-A, Ind	Stop-M
High current protection	High I	Yes, No	No
Type of operation for high current protection	High I Op	Stop-M, Stop-A, Ind	Stop-M
Phase reversal protection	Phase Rev	Yes, No	No
Type of operation for phase reversal protection	Ph Rev Op	Stop-M, Stop-A, Ind	Stop-M
PTC protection	PTC	Yes, No	No
Type of operation for PTC protection	PTC Op	Stop-M, Stop-A	Stop-M
An external bypass contactor is used	Ext ByPass	Yes, No	No
High current warning	Warn I=High	Yes, No	No
Trip level for high current warning	Wa I=H Lev	0.5 ... 5.0 x I _l	1.2 x I _l
Low current warning	Warn I=Low	Yes, No	No
Trip level for low current warning	Wa I=L Lev	0.4 ... 1.0 x I _l	0.8 x I _l
Overload warning	Warn OL	Yes, No	No
Trip level for overload warning	Wa OL Lev	40 ... 99%	90%
Thyristor overload warning	Warn SCR OL	Yes, No	No
Type of operation for phase loss fault	Ph Loss Op	Stop-M, Stop-A	Stop-M
Type of operation for by-pass doesn't close	BP open Op	Stop-M, Stop-A	Stop-M
Type of operation for by-pass doesn't open	BP closed Op	Stop-M, Stop-A	Stop-M
Type of operation for fieldbus fault	FB Fault Op	Stop-M, Stop-A	Stop-M
Type of operation for frequency fault	Freq F Op	Stop-M, Stop-A	Stop-M
Type of operation for heat sink over temperature fault	HS Temp Op	Stop-M, Stop-A	Stop-M
Type of operation for thyristor short circuit fault	SCR SC Op	Stop-M, Stop-A	Stop-M
Function of programmable input In_0	In0	None, Reset, Enable, Jog, DOL, Start 2, FB-Dis	Reset
Function of programmable input In_1	In1	None, Reset, Enable, Jog, DOL, Start 3, FB-Dis	Reset
Function of programmable relay output K4	Relay K4	Run, TOR, Event	Run
Function of programmable relay output K5	Relay K5	Run, TOR, Event	TOR
Function of programmable relay output K6	Relay K6	Run, TOR, Event	Event
Control of the softstarter with fieldbus	Fieldb Ctrl	Yes, No	No
Number of sequences for sequence start.	No of Seq	No, 2, 3	No
Language to use on display	Language	US/UK, FI, SE, PT, NL, IT, FR, ES, DE, CN, RU, TR, PL, CZ	US/UK
Password for display	Password	No, 1 ... 255	No
Start mode	Start Mode	Volt, Torque	Volt
Stop mode	Stop Mode	Volt, Torque	Volt
Torque limit	Torque limit	20 ... 200%	150%
Analog output	Analogue Out	Yes, No	No
Analog output, reference	Anl Ref	0 ... 10 V, 0 ... 20 mA, 4 ... 20 mA	4 ... 20 mA
Analog output, type of value	Anl Type	I Amp, U Volt, P kW, P hp, Q kVA, S kVA, TmpMot, TmpSCR, cosPhi	I Amp

PST(B) – The advanced range

Technical data

Tripping curves for the integrated electronic overload protection

All units have an integrated electronic overload protection that can be set to four different tripping classes. Below you find a curve for each tripping class in cold state. These tripping curves are valid for PSE, PST, and PST(B).

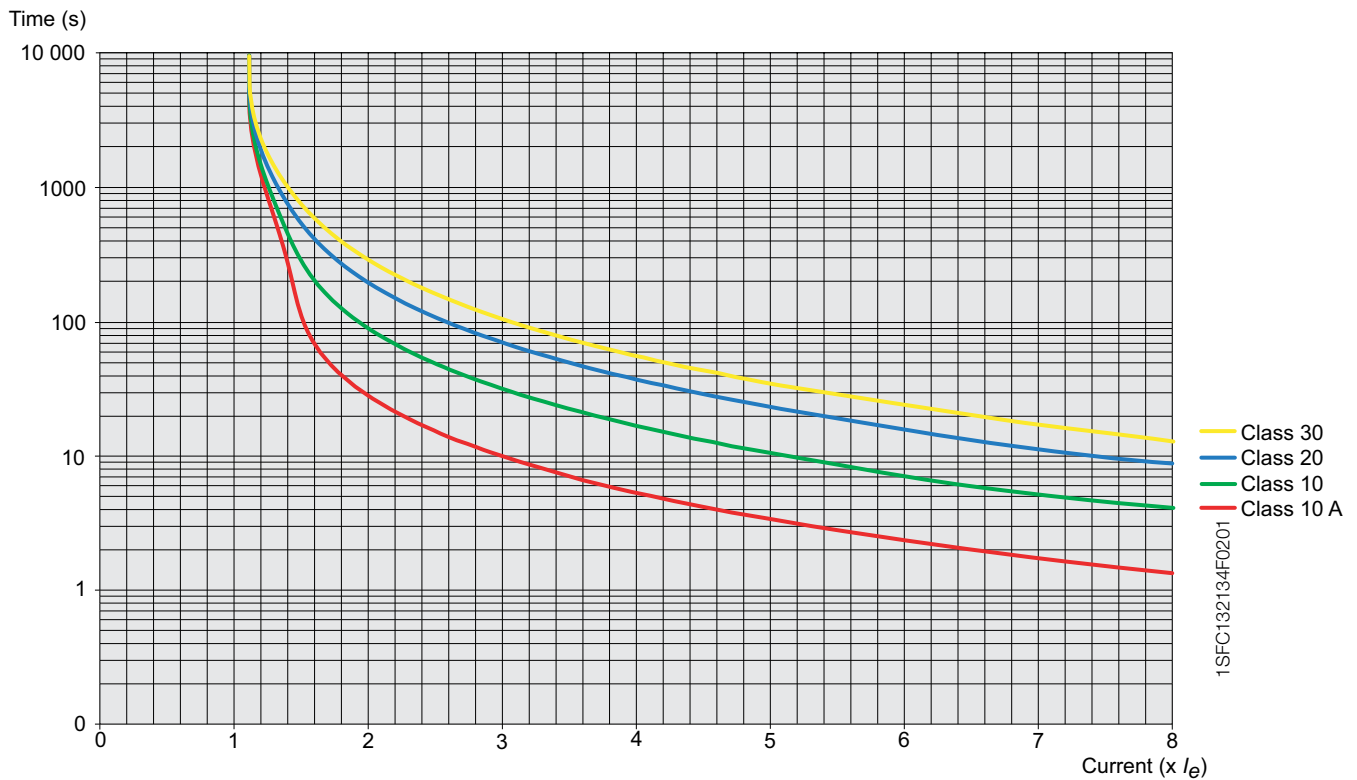

Tripping curves for electronic overload protection (Cold) for PSE, PST and PSTB.



PST(B) – The advanced range

Technical data

Cross section of connection cables

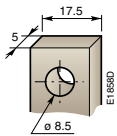
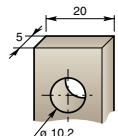
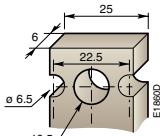
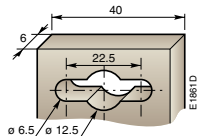
		Type of softstarter				
		PST30 ... 72	PST85 ... 142	PST175 ... 300	PSTB370 ... 470	PSTB570 ... 1050
Main circuit						
Available terminals:	L1, L2, L3	Yes	Yes	Yes	Yes	Yes
	T1, T2, T3	Yes	Yes	Yes	Yes	Yes
(For external by-pass)	B1, B2, B3	Yes	Yes	Yes	No	No
Connection clamp						
Solid/stranded	1 x mm ²	10 ... 95			See accessories	
Solid/stranded	2 x mm ²	6 ... 35			See accessories	
Tightening torque (recommended)	Nm	6.0			See accessories	
Connection bar	No					
Width and thickness	mm	–				
Hole diameter	mm	–	ø 8.5	ø 10.2	ø 10.5	ø 6.5 / ø 12.5
Tightening torque (recommended)	Nm	–	18	28	35	45
Supply and control circuit						
Connection clamp					Yes	
Solid/stranded	1 x mm ²				2.5	
Solid/stranded	2 x mm ²				1.5	
Tightening torque (recommended)	Nm				0.5	

Fuse ratings and power losses

For softstarter	Recommended ABB's overload protection		Max power loss at rated I _e		Max fuse rating - main circuit ¹⁾³⁾			Power requirements supply circuit Holding (VA) / Pull-in (VA)
	Type	Current range	without by-pass ²⁾	with by-pass	Bussmann fuses, DIN43 620 (Knife)			
			W	W	A	Type	Size	
PST								
PST30	Integrated	9...35	100	9.5	80	170M1566	000	5
PST37	Integrated	11...43	120	10.5	125	170M1568	000	5
PST44	Integrated	13...51	140	13.5	160	170M1569	000	5
PST50	Integrated	15...58	160	13.5	160	170M1569	000	5
PST60	Integrated	18...69	190	15.5	200	170M1570	000	5
PST72	Integrated	22...83	230	17	250	170M1571	000	5
PST85	Integrated	25...98	270	30.5	315	170M1572	000	10
PST105	Integrated	32...120	325	35	400	170M3819	1*	10
PST142	Integrated	43...163	435	37	450	170M5809	2	10
PST175	Integrated	53...201	540	62	500	170M5810	2	15
PST210	Integrated	63...241	645	67	630	170M5812	2	15
PST250	Integrated	75...288	765	67	700	170M5813	2	15
PST300	Integrated	90...345	920	90	900	170M6813	3	15
PSTB 600 V								
PSTB370	Integrated	111...425	N/A	90	700	170M5813	2	20/480
PSTB470	Integrated	141...540	N/A	110	900	170M6813	3	20/480
PSTB570	Integrated	171...655	N/A	105	900	170M6813	3	25/900
PSTB720	Integrated	216...828	N/A	110	1250	170M8554	3	25/860
PSTB840	Integrated	252...966	N/A	170	1500	170M6018 ⁴⁾	3	25/860
PSTB1050	Integrated	315...1207	N/A	170	1800	170M6020 ⁴⁾	3	25/860
PSTB 690 V								
PSTB370	Integrated	111...425	N/A	90	700	170M5813	2	20/480
PSTB470	Integrated	141...540	N/A	110	900	170M6813	3	20/480
PSTB570	Integrated	171...655	N/A	105	900	170M6813	3	25/900
PSTB720	Integrated	216...828	N/A	110	1250	170M8554	3	25/860
PSTB840	Integrated	252...966	N/A	170	1500	170M6018 ⁴⁾	3	25/860
PSTB1050	Integrated	315...1207	N/A	170	1600	170M6019 ⁴⁾	3	25/860

¹⁾ For the supply circuit 6 A delayed, for MCB use C characteristics.

²⁾ See PSS page 24

³⁾ Max fuse rating independent if in-line or inside delta connection. In inside delta connections of PST, the fuses can be placed outside of the delta. For PSTB the fuses shall be placed inside the delta. Contact ABB for more information.

⁴⁾ DIN43 653

PST(B) – The advanced range

UL ratings

3-phase motor rating – in-line

Softstarters		Motor power P (hp) and full load current FLA (A)			
Type	Max. FLA A	U _e 200V/208 V hp	U _e 220 V/240 V hp	U _e 440 V/480 V hp	U _e 550 V/600 V hp
PST30	28	7.5	10	20	25
PST37	34	10	10	25	30
PST44	42	10	15	30	40
PST50	54	15	20	40	50
PST60	60	20	20	40	50
PST72	68	20	25	50	60
PST85	80	25	30	60	75
PST105	104	30	40	75	100
PST142	130	40	50	100	125
PST175	156	50	60	125	150
PST210	192	60	75	150	200
PST250	248	75	100	200	250
PST300	302	100	100	250	300
PSTB370	361	125	150	300	350
PSTB470	480	150	200	400	500
PSTB570	590	200	250	500	600
PSTB720	720	250	300	600	700
PSTB840	840	300	350	700	800
PSTB1050	1062	400	450	900	1000

3-phase motor rating – inside delta

Softstarters		Motor power P (hp) and full load current FLA (A)			
Type	Max. FLA A	U _e 200 V/208 V hp	U _e 220 V/240 V hp	U _e 440 V/480 V hp	U _e 550 V/600 V hp
PST30	42	10	15	30	40
PST37	54	15	20	40	50
PST44	72	20	25	50	60
PST50	80	25	30	60	75
PST60	104	30	40	75	100
PST72	104	30	40	75	100
PST85	130	40	50	100	125
PST105	156	50	60	125	150
PST142	192	60	75	150	200
PST175	248	75	100	200	250
PST210	302	100	100	250	300
PST250	361	125	150	300	350
PST300	480	150	200	400	500
PSTB370	590	200	250	500	600
PSTB470	720	250	300	600	700
PSTB570	840	300	350	700	800
PSTB720	1247	400	500	1000	1200
PSTB840	1454	500	600	1200	1500
PSTB1050	1839	600	700	1500	1800



DeviceNet FieldBusPlug

Ready-made DeviceNet fieldbus interface with various cable lengths.

- Applicable on all FBP motor starters and other devices
- Degree of protection IP65, diagnostic LED

Designation	Cable length	Type	Order code	Pack ^{ing} piece	Weight kg 1 piece
DeviceNet-FBP	0.25 m	DNP21-FBP.025	1SAJ230000R1003	1	0.09
DeviceNet-FBP	0.50 m	DNP21-FBP.050	1SAJ230000R1005	1	0.10
DeviceNet-FBP	1.00 m	DNP21-FBP.100	1SAJ230000R1010	1	0.13
DeviceNet-FBP	5.00 m	DNP21-FBP.500	1SAJ230000R1050	1	0.36

MODBUS-RTU FieldBusPlug

Ready-made MODBUS-RTU fieldbus interface with various cable lengths.

- Applicable on all FBP motor starters and other devices
- Degree of protection IP65, diagnostic LED

Designation	Cable length	Type	Order code	Pack ^{ing} piece	Weight kg 1 piece
MODBUS-RTU-FBP	0.25 m	MRP21-FBP.025	1SAJ250000R0003	1	0.09
MODBUS-RTU-FBP	0.50 m	MRP21-FBP.050	1SAJ250000R0005	1	0.10
MODBUS-RTU-FBP	1.00 m	MRP21-FBP.100	1SAJ250000R0010	1	0.13
MODBUS-RTU-FBP	5.00 m	MRP21-FBP.500	1SAJ250000R0050	1	0.36

CANopen FieldBusPlug

Ready-made CANopen fieldbus interface with various cable lengths.

- Applicable on all FBP motor starters and other devices
- Degree of protection IP65, diagnostic LED

Designation	Cable length	Type	Order code	Pack ^{ing} piece	Weight kg 1 piece
CANopen-FBP	0.25 m	COP21-FBP.025	1SAJ230100R1003	1	0.09
CANopen-FBP	0.50 m	COP21-FBP.050	1SAJ230100R1005	1	0.10
CANopen-FBP	1.00 m	COP21-FBP.100	1SAJ230100R1010	1	0.13



DNP21-FBP
MRP21-FBP
COP21-FBP

To connect the PST softstarter to a DeviceNet or CANopen fieldbus system...

you need specific software for PLC setup, (EDS file) which is available at www.abb.com/lowvoltage on the Softstarter pages. Look under the documentation-link named Software. If you need help or advice, please contact your local ABB office.

Accessories for the DeviceNet, MODBUS-RTU and CANopen bus connector



DNF11-FBP.050



DNM11-FBP.050



DNX11-FDP



DNM11-FBP.0

DNF11-FBP.0



DNR11-FBP.120

DeviceNet, MODBUS-RTU and CANopen round cable for bus junctions

Ready-made bus cable with an M12 connector and an open cable end.

Designation	Cable length	Type	Order code	Packing piece	Weight kg 1 piece
Round cable with female connector	0.50 m	DNF11-FBP.050	1SAJ923002R0005	1	0.04
Round cable with male connector	0.50 m	DNM11-FBP.050	1SAJ923003R0005	1	0.04

DeviceNet, MODBUS-RTU and CANopen round cable for bus extension

Ready-made bus cable with M12 male and female connectors

Designation	Cable length	Type	Order code	Packing piece	Weight kg 1 piece
Extension cable	1.00 m	DNX11-FBP.100	1SAJ923001R0010	1	0.08
Extension cable	3.00 m	DNX11-FBP.300	1SAJ923001R0030	1	0.20
Extension cable	5.00 m	DNX11-FBP.500	1SAJ923001R0050	1	0.31
Round cable	100.00 m	DNC11-FBP.999	1SAJ923004R0001	1	5.60

DeviceNet, MODBUS-RTU and CANopen round cable connectors

Bus cable and coupling accessories

Designation	Type	Order code	Packing piece	Weight kg 1 piece
Male connector for round cable	DNM11-FBP.0	1SAJ923005R0001	5	0.15
Female connector for round cable	DNF11-FBP.0	1SAJ923006R0001	5	0.15

DeviceNet, MODBUS-RTU and CANopen termination resistor

Designation	Type	Order code	Packing piece	Weight kg 1 piece
Termination Resistor, 120 Ohm	DNR11-FBP.120	1SAJ923007R0001	1	0.02

FBP FieldBusPlug

Profibus DP, ordering details



Profibus DP FieldBusPlug

Ready-made Profibus DP fieldbus interface with various cable lengths.

- Supports PROFIBUS DP V0 and V1
- Applicable on all FBP motor starters and other devices
- Degree of protection IP65, diagnostic LED



PDP22-FBP

Designation	Cable length	Type	Order code	Pack ^{ing} piece	Weight kg 1 piece
Profibus DP FBP	0.25 m	PDP22-FBP.025	1SAJ240100R1003	1	0.09
Profibus DP FBP	0.50 m	PDP22-FBP.050	1SAJ240100R1005	1	0.10
Profibus DP FBP	1.00 m	PDP22-FBP.100	1SAJ240100R1010	1	0.13
Profibus DP FBP	2.00 m	PDP22-FBP.200	1SAJ240100R1020	1	0.20
Profibus DP FBP	5.00 m	PDP22-FBP.500	1SAJ240100R1050	1	0.36

Profibus DP FieldBusPlug for four devices

PDQ22 is a member of the ABB's FieldBusPlug family of bus connectors. It allows the connection of up to four devices to Profibus DP by just using one Profibus node access. This allows a cost efficient device integration for devices that are located physically nearby. PDQ22 supports DP-V0 and DP-V1. The degree of protection is IP66. There are separate diagnosis LEDs for bus and device status.



PDQ22-FBP

Note that the accessory PDQ22-FBP only works with the PSR and PSE and not with the PST(B) softstarter.

Designation	Type	Order code	Pack ^{ing} piece	Weight kg 1 piece
Quadruple bus connector	PDQ22-FBP	1SAJ240200R0050	1	0.20
DINrail adapter for PDQ22-FBP	CDA11-FBP.0	1SAJ929300R0001	1	0.11
Fixing bracket for passive plug of connection cable	CDP11-FBP.0	1SAJ929100R0001	1	0.50

Configuration software

This cable and software can be used for setup and commissioning of the softstarter as well as to keep back-up of the parameter settings.



2DC5410180010

Designation	Type	Order code	Pack ^{ing} piece	Weight kg 1 piece
USB to FBP interface cable	UTF21-FBP	1SAJ929400R0002	1	
PDP22/PDQ22 Device Type Manager (DTM) incl. FDT/DTM frame application	PBDTM-FBP	1SAJ924012R0003	1	

To connect the PST softstarter to a Profibus DP fieldbus system...

you need specific software for PLC setup, (GSD file) which is available at www.abb.com/lowvoltage on the softstarter pages. Look under the documentation-link named Software. If you need help or advice, please contact your local ABB office.

PDP21 is replaced by PDP22.

Use PDP22 with the GSD-file Abb_082d.gsd regardless if the PLC is a DP/V0 or DP/V1.



Accessories for the Profibus DP Bus Connector

Profibus DP Round cable for Bus Junctions

Ready-made bus cable with an M12 connector and an open cable end.

- Application on bus junctions such as e.g. Profibus DB couplers or devices with an integrated Profibus DB interface



Designation	Cable length	Type	Order code	Pack ^{ing} piece	Weight kg 1 piece
Round cable with female connector	0.50 m	PDF11-FBP.050	1SAJ924002R0005	1	0.04
Round cable with male connector	0.50 m	PDM11-FBP.050	1SAJ924003R0005	1	0.04

Profibus DP round cable for bus extension

Ready-made bus cable with M12 male and female connectors

Round cable on coil



Designation	Cable length	Type	Order code	Pack ^{ing} piece	Weight kg 1 piece
Extension cable	0.50 m	PDX11-FBP.050	1SAJ924001R0005	1	0.04
Extension cable	1.00 m	PDX11-FBP.100	1SAJ924001R0010	1	0.08
Extension cable	3.00 m	PDX11-FBP.300	1SAJ924001R0030	1	0.20
Extension cable	5.00 m	PDX11-FBP.500	1SAJ924001R0050	1	0.31
Round cable	100.00 m	PDC11-FBP.999	1SAJ924004R1000	1	5.60

Profibus DP accessories for bus extension



Designation	Type	Order code	Pack ^{ing} piece	Weight kg 1 piece
Male Connector for round cable	PDM11-FBP.0	1SAJ924005R0001	5	0.03
Female Connector for round cable	PDF11-FBP.0	1SAJ924006R0001	5	0.03



Profibus DP termination resistor, miscellaneous accessories

Designation	Type	Order code	Pack ^{ing} piece	Weight kg 1 piece
Termination resistor, 150 Ohm	PDR11-FBP.150	1SAJ924007R0001	1	0.03
Feeding connector 24V DC, Code B-A	PDV11-FBP.0	1SAJ924008R0001	1	0.04
Feeding connector 24V DC, Code A-A	PDV12-FBP.0	1SAJ924011R0001	1	0.04
Adaptor M12-Dsub9-M12 Cable length 0.50m	PDA11-FBP.050	1SAJ924009R0001	1	0.04
Adaptor M12-Dsub9-M12 Cable length 2 x 0.50m	PDA12-FBP.050	1SAJ924010R0001	1	0.04



Extension cable

Designation	Cable length	Type	Order code	Pack ^{ing} piece	Weight kg 1 piece
Extension cable (female/male), shielded	0.3 m	CDP15-FBP.030	1SAJ929140R0003	1	
Extension cable (female/male), shielded	0.6 m	CDP15-FBP.060	1SAJ929140R0006	1	
Extension cable (female/male), shielded	1.5 m	CDP15-FBP.150	1SAJ929140R0015	1	0.20
Extension cable (male/open), shielded	1.5 m	CDP16-FBP.150	1SAJ929150R0015	1	0.20

Wall mounting instructions Softstarters

Minimum distance to wall/front

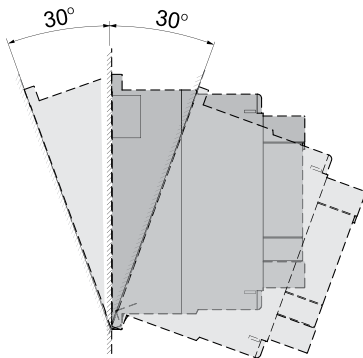
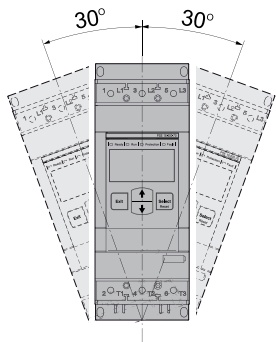
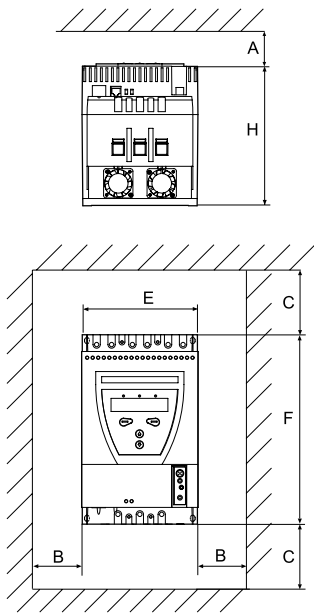

Dimensions

Softstarter, type	A	B	C	E	F	H
PSR						
PSR3 ... 16	25	0*	0	45	140	114
PSR25 ... 30	25	0*	0	45	160	128
PSR37 ... 45	25	0*	0	54	187	153
PSR60 ... 105	25	0*	0	70	220	180
PSS ... -500 for 500 V						
PSS18/30 ... 44/76	20	10	100	120	200	162
PSS50/85 ... 72/124	20	10	100	140	250	162
PSS85/147 ... 142/245	20	10	100	181	340	265
PSS175/300 ... 300/515	20	10	100	356	340	265
PSS ... -690 for 690 V						
PSS18/30 ... 72/124	20	10	100	140	250	163
PSS85/147 ... 142/245	20	10	100	181	340	265
PSS175/300 ... 300/515	20	10	100	356	340	265
PSE						
PSE18 ... 105	20	10	100	90	245	185.5
PSE142 ... 170	20	10	100	130	295	219.5
PSE210 ... 370	20	10	100	190	550	236.5
PST						
PST30 ... 72	20	10	100	160	260	196
PST85 ... 142	20	10	100	186	390	270
PST175 ... 300	20	10	100	360	420	270
PSTB						
PSTB370 ... 470	20	15	150	365	460	361
PSTB570 ... 1050	20	15	150	435	515	381

*) 5 mm for the 24 V DC version

Dimensions PSTEK

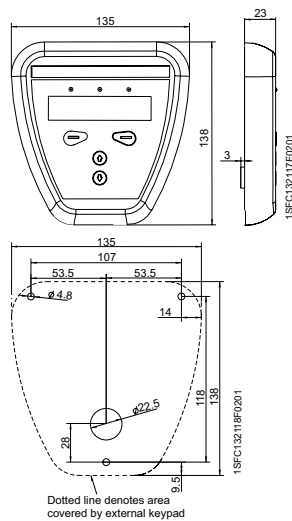

PSEEK

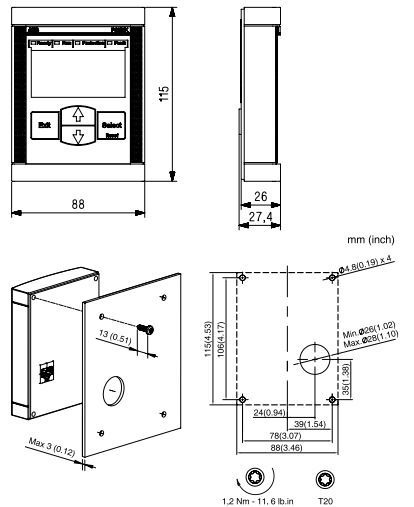

Dimensions in mm

Dimensions

Softstarters, type PSR

PSR3 ... 16

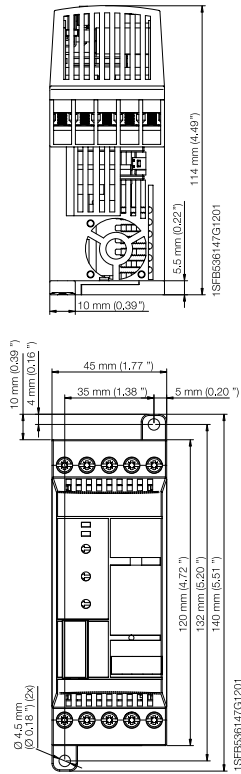

PSR37 ... 45

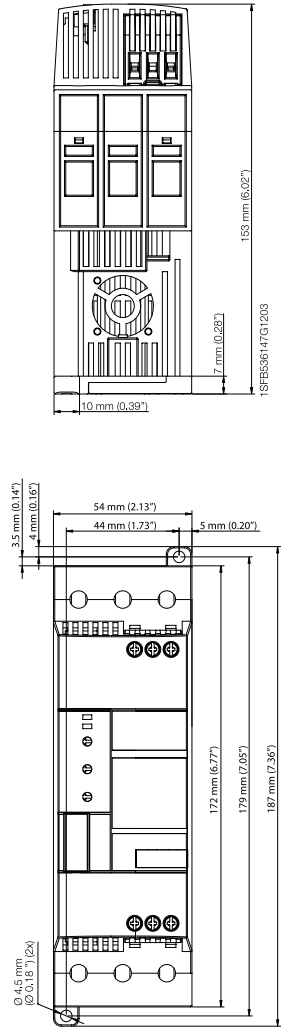

PSR60 ... 105

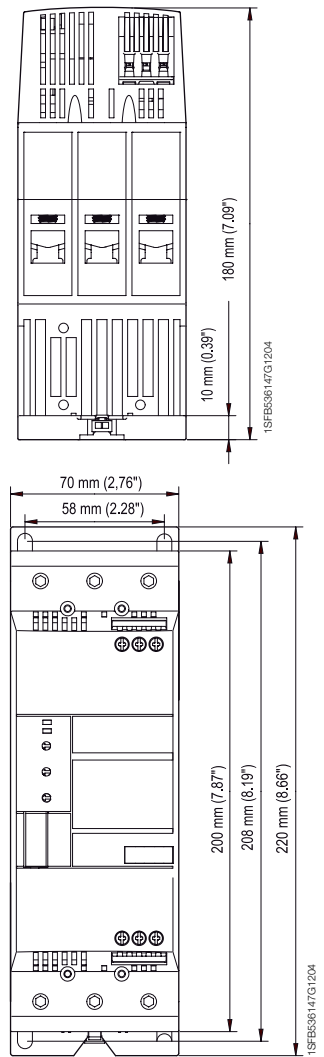

PSR25 ... 30

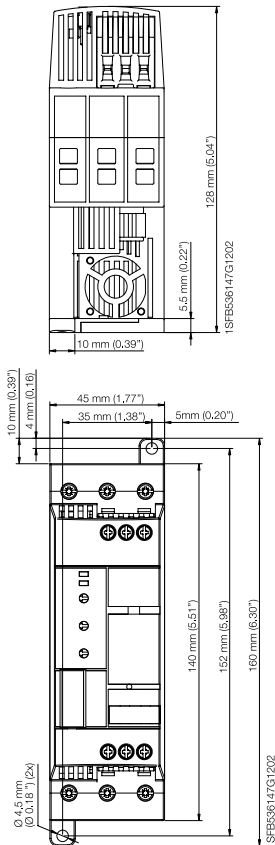

Dimensions in mm (and inches)

Dimensions Softstarters, type PSS

PSS18/30-500 ... 44/76-500

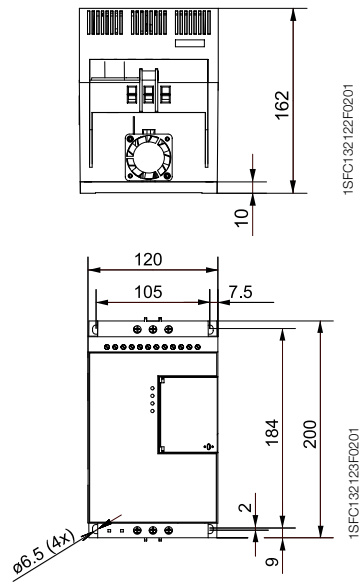

PSS50/85-500 ... 72/124-500
PSS18/30-690 ... 72/124-690

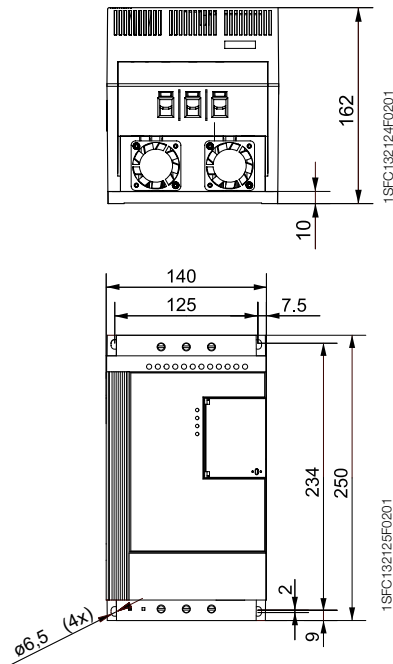

PSS85/147-500 ... 142/245-500
PSS85/147-690 ... 142/245-690

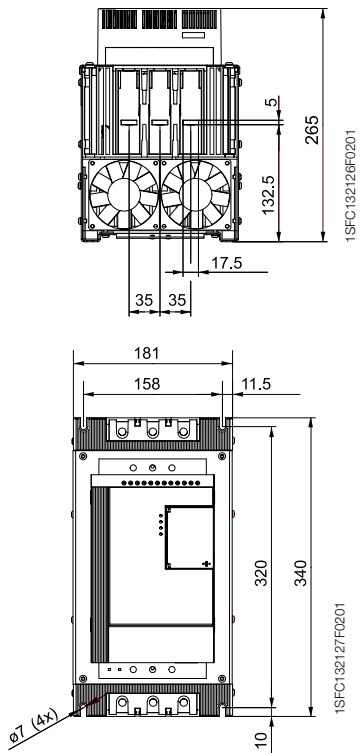

PSS 175/300-500 ... 300/515-500
PSS 175/300-690 ... 300/515-690

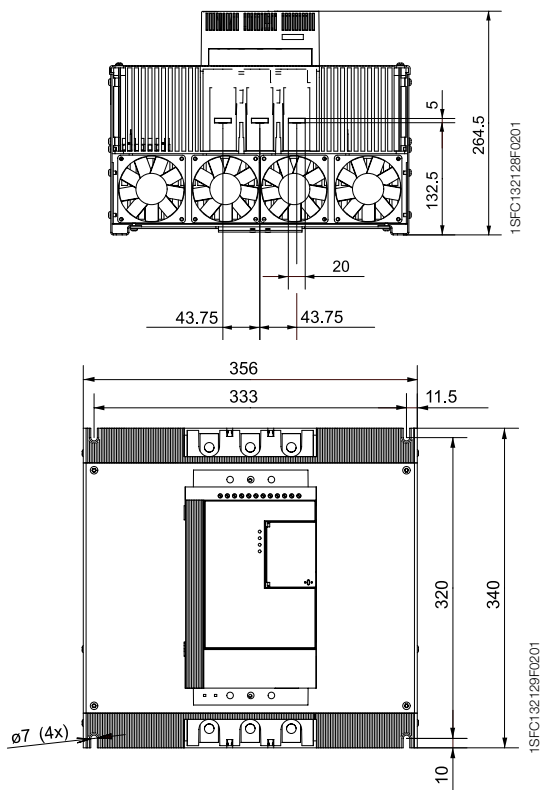

Dimensions in mm

Dimensions

Sofstarters, type PSE

PSE18 ... 105

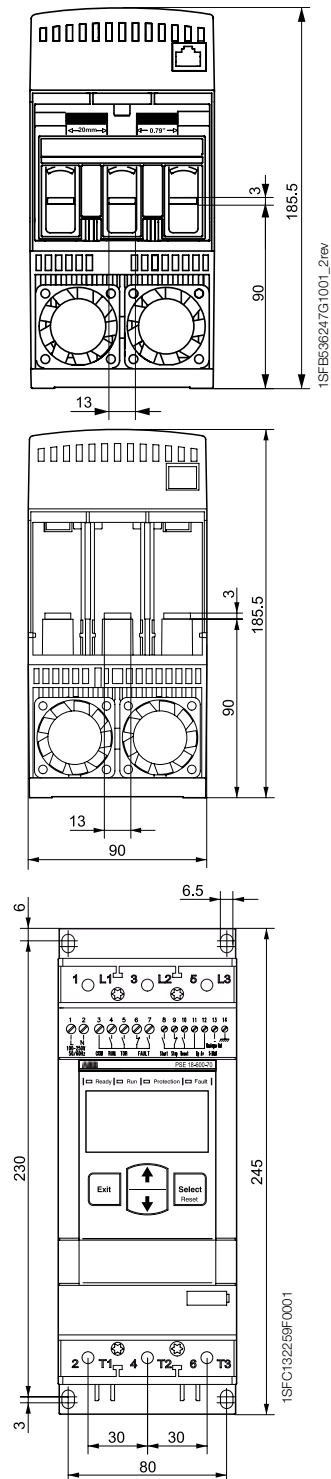

PSE142 ...170

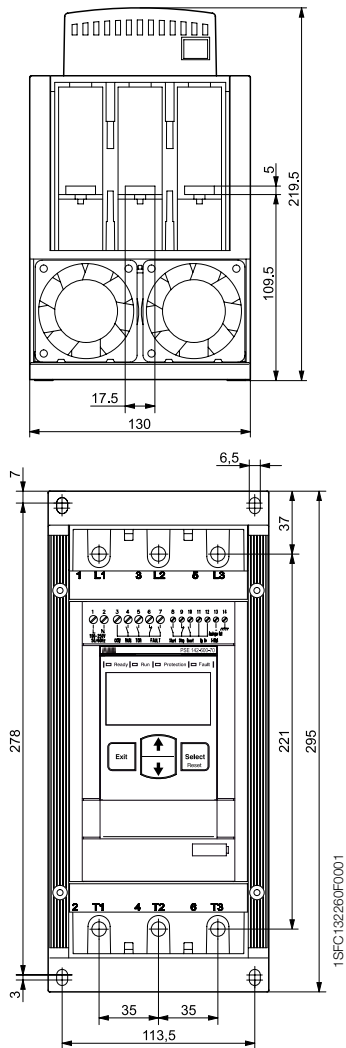

PSE210 ... 370

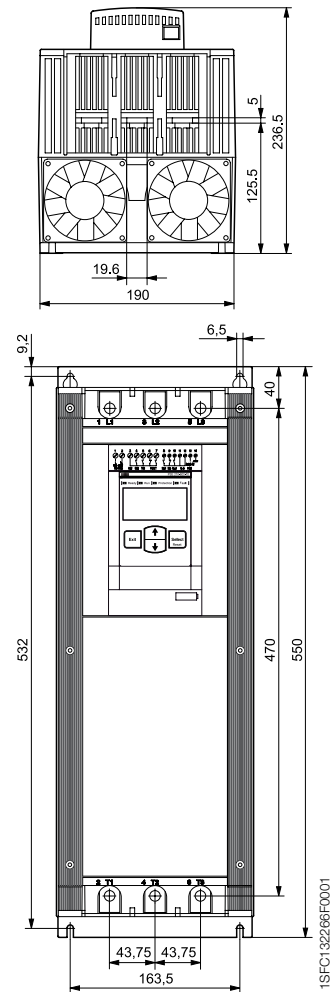

Dimensions in mm

Dimensions

Softstarters, type PST and PSTB

PST30 ... 72

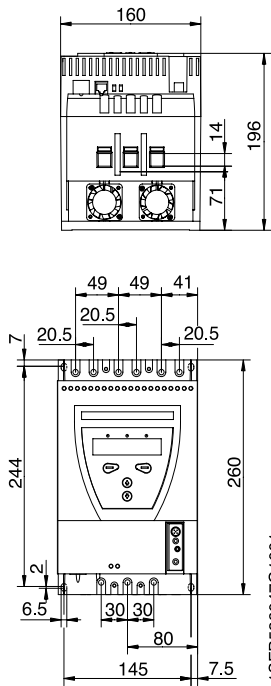

PST85 ...142

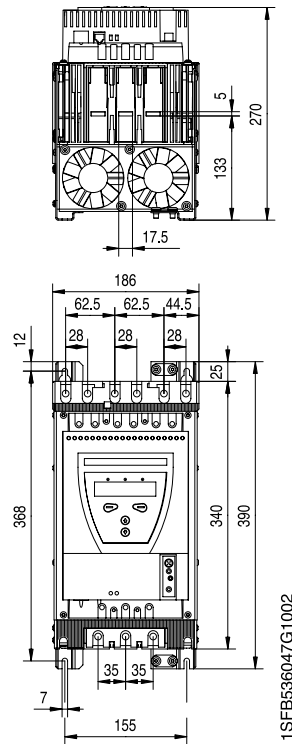

PST85 ...142 with marine kit

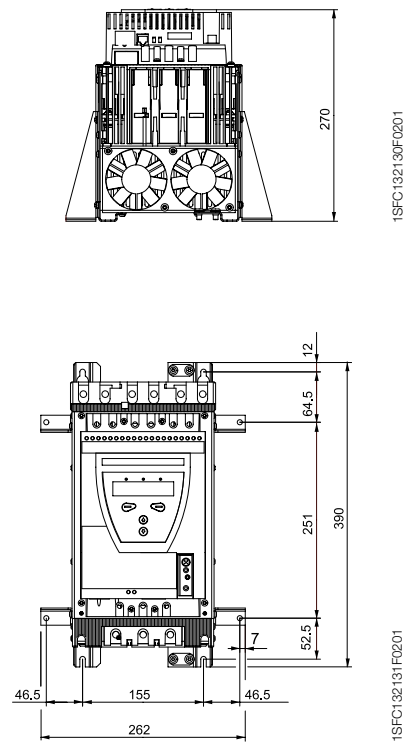

PST175 ... 300

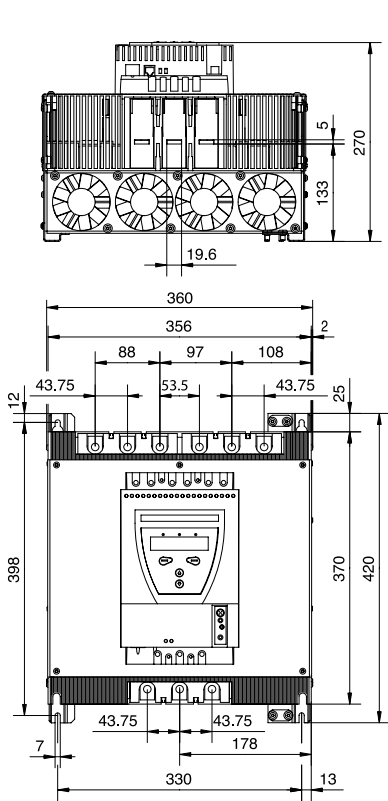

PSTB370 ... 470

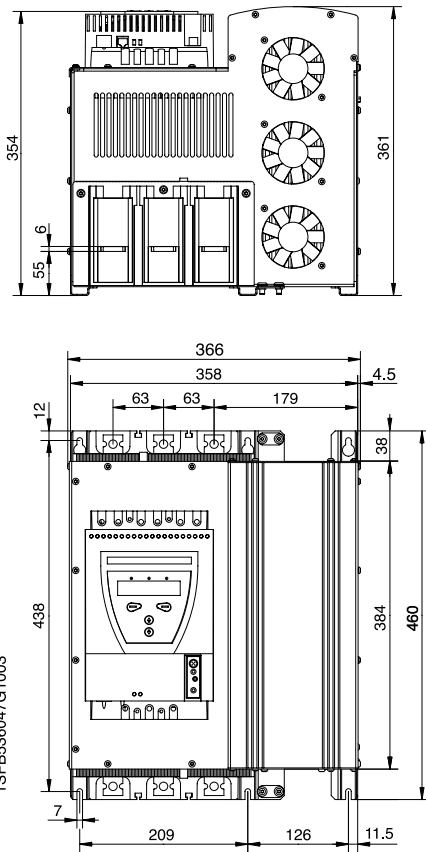

PSTB570 ... 1050

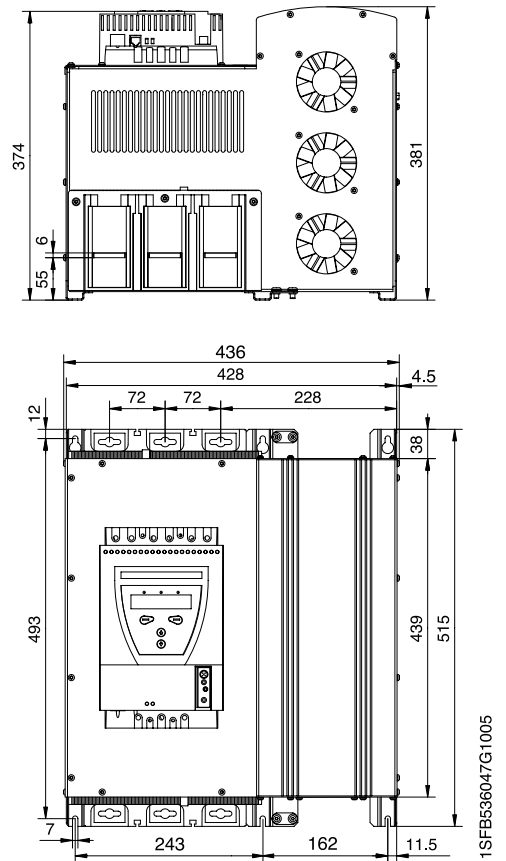

Dimensions in mm

Circuit diagrams

Softstarters, type PSR

PSR3 ...16

A) With MMS

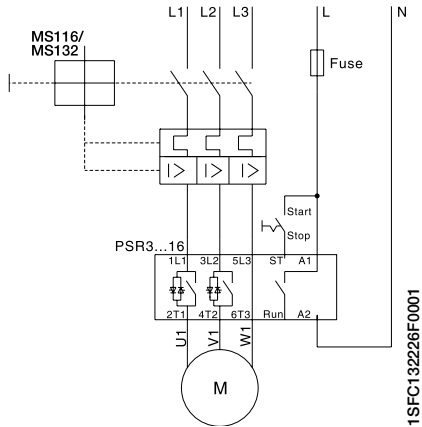

B) With MMS and auxiliary contact

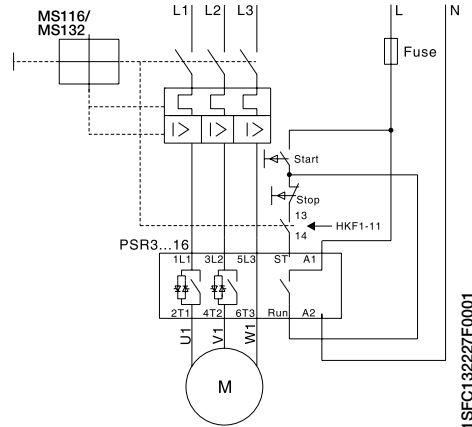

C) With fuses, contactor and O.L.

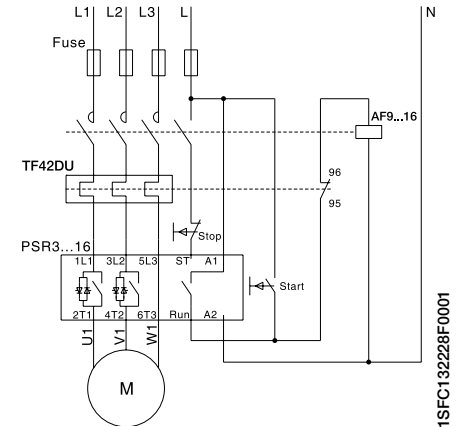

PSR25 ... 45

D) With MMS

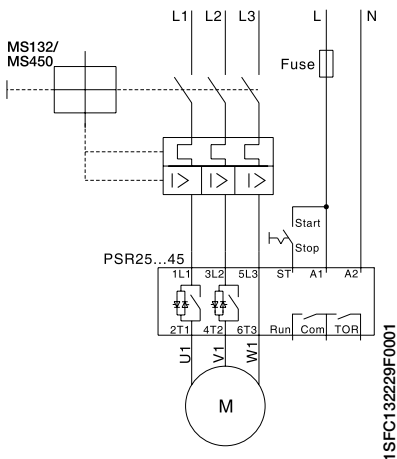

E) With MMS and auxiliary contact

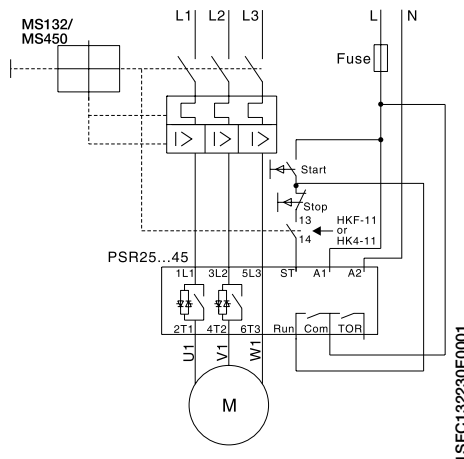

F) With fuses, contactor and O.L.

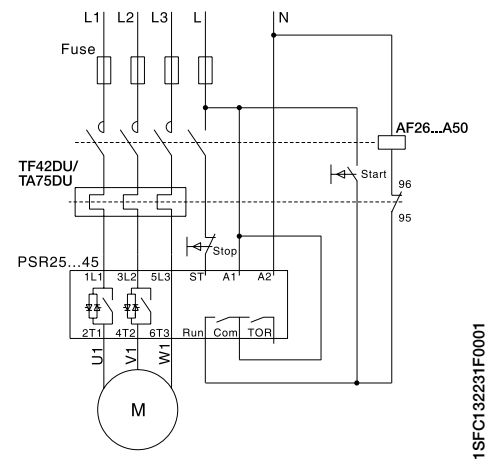

PSR60 ... 105

G) With MMS

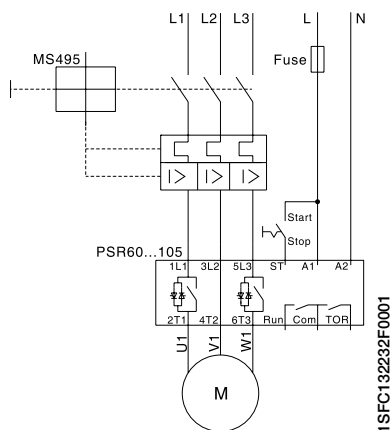

H) With MMS and auxiliary contact

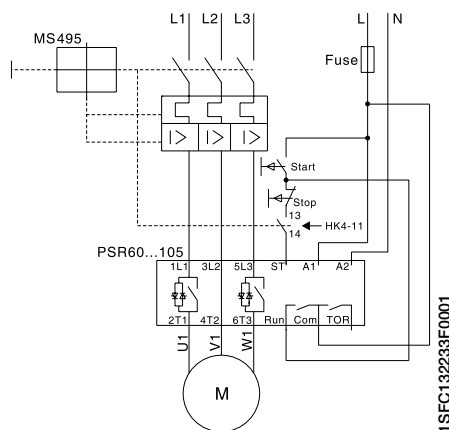

I) With fuses, contactor and O.L.

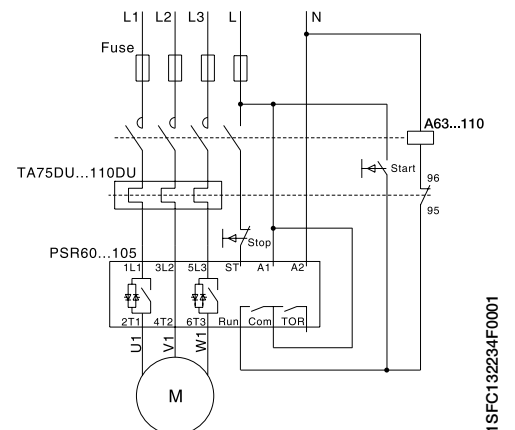

Circuit diagrams

Softstarters, type PSS and PSE

PSS18/30...300/515

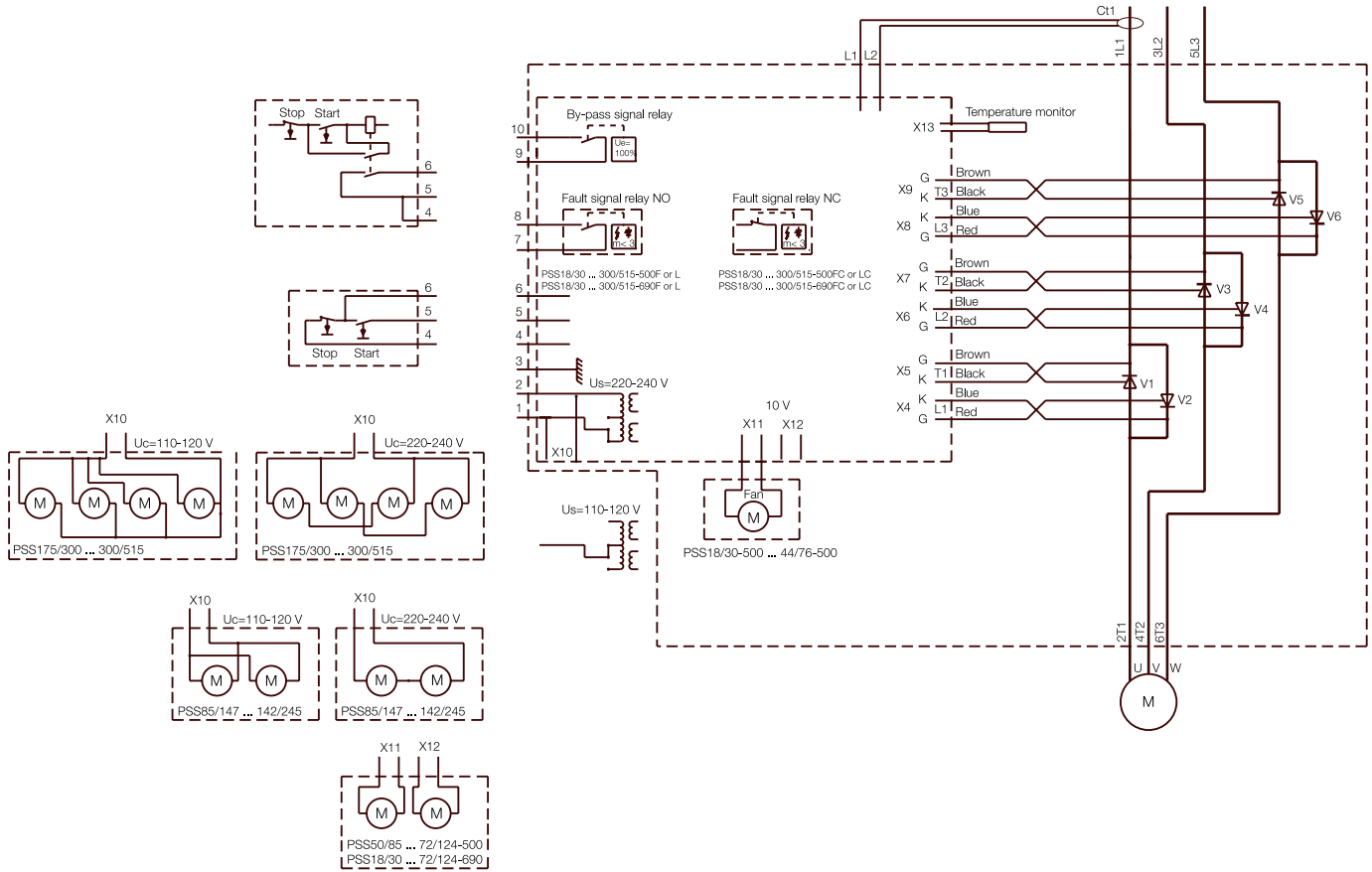

PSE18 ... 370

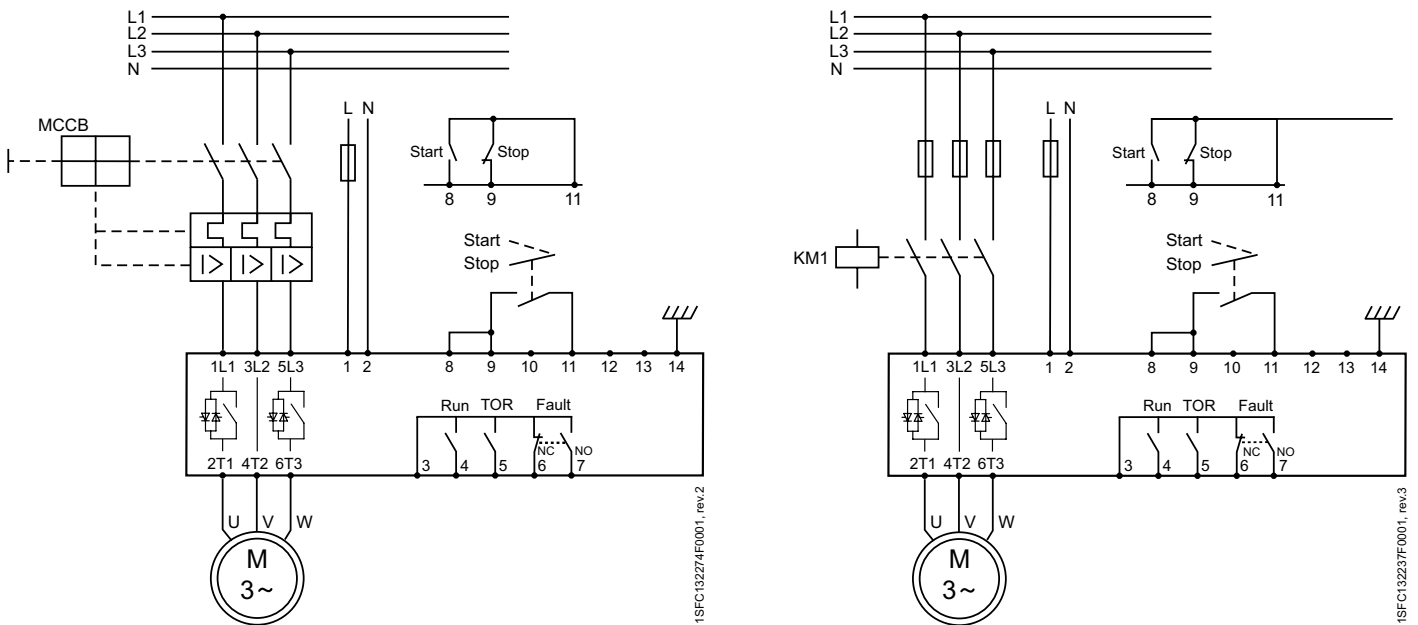

For more circuit diagrams see www.abb.com/lowvoltage, choose Control Products, Softstarters and Softstarters once more.

Circuit diagrams

Softstarters, type PST and PSTB

PST30...300

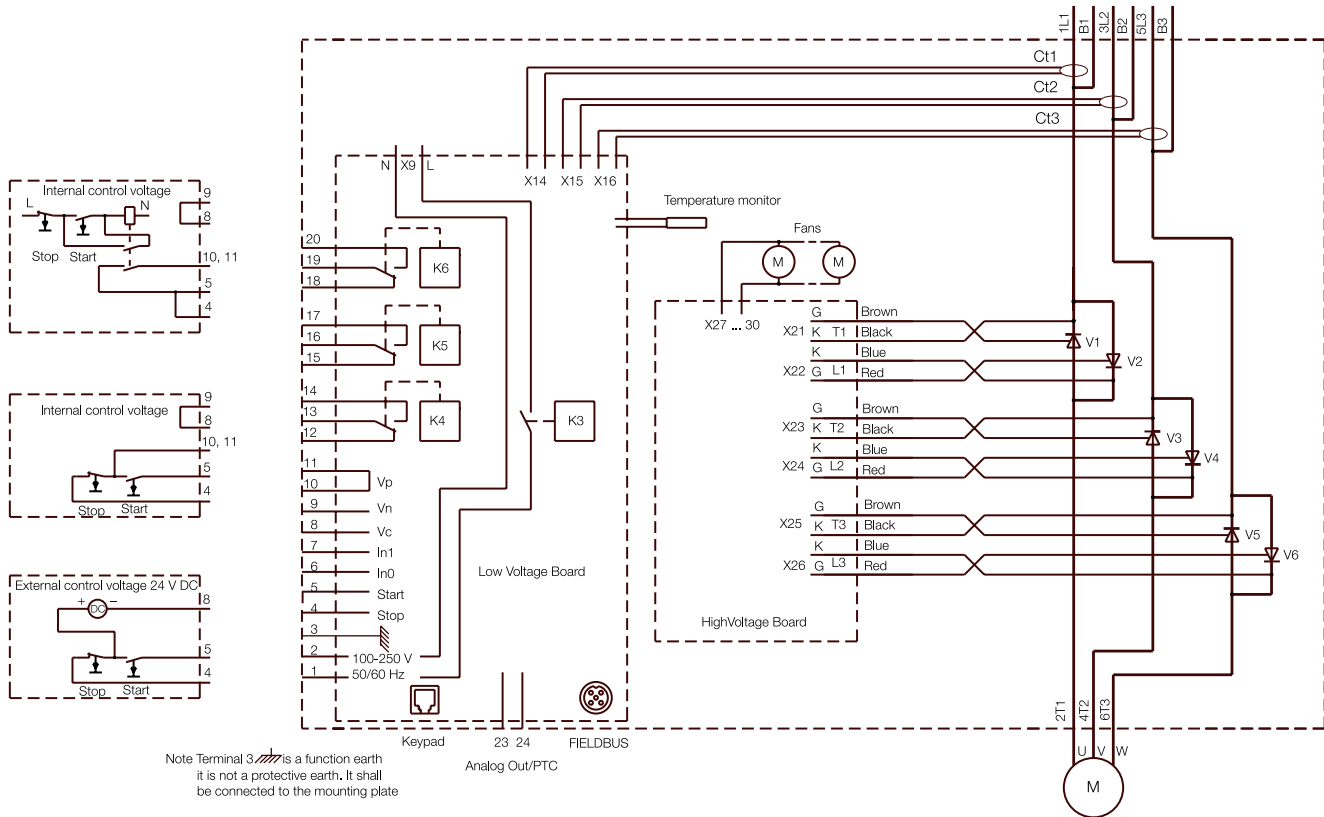

PSTB370...1050

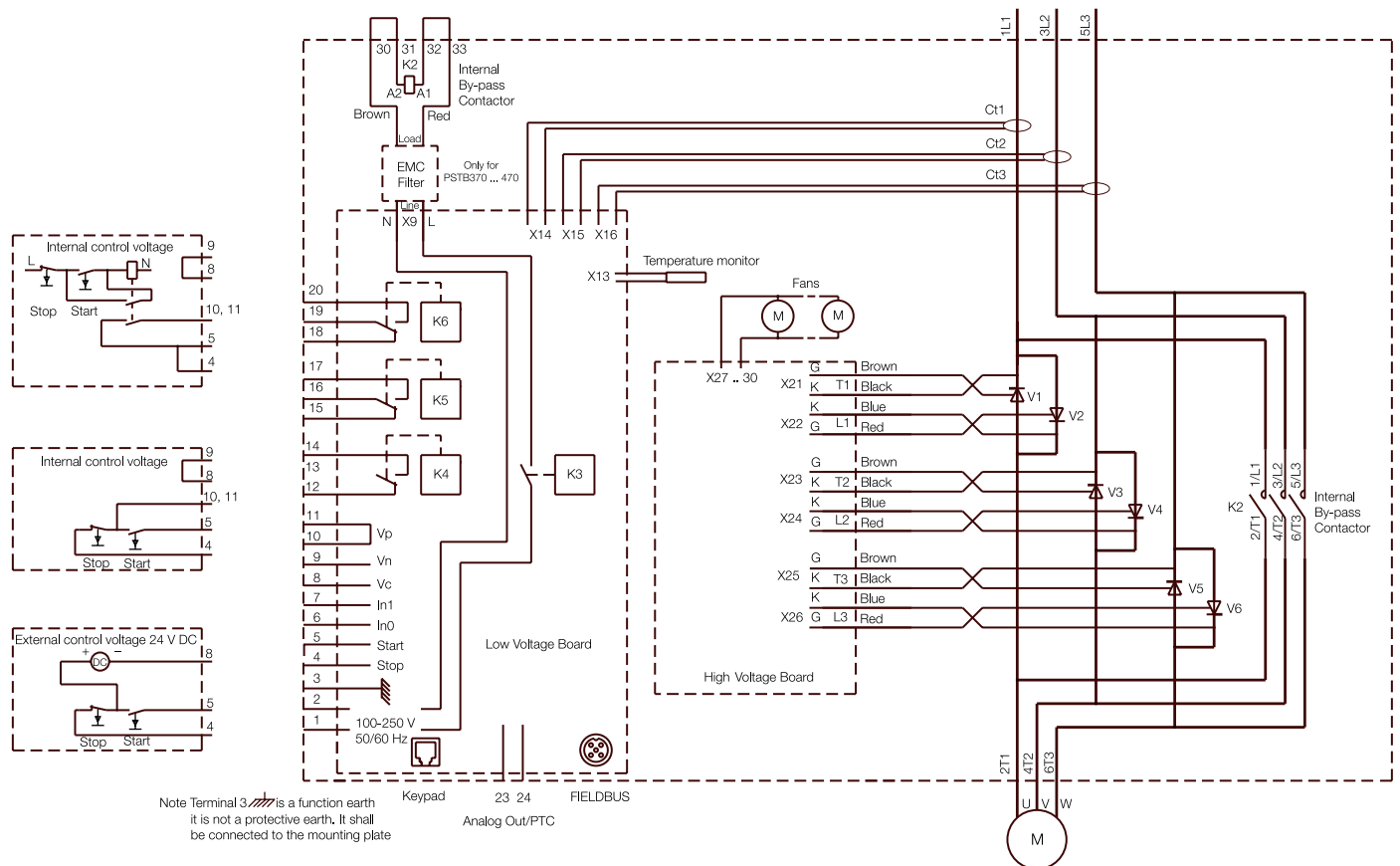

For more circuit diagrams see www.abb.com/lowvoltage, choose Control Products, Softstarters and Softstarters once more.

Softstarter selection tool and coordination tables

Softstarter selection tool

The selection of a softstarter can be done according to this catalog. This will work fine in the majority of cases but by using the softstarter selection tool, a more optimized selection will be achieved. Especially in extremely heavy-duty applications with several minutes starting time, the use of the selection tool is recommended.

When using the softstarter selection tool, the selection is done in three steps, which can be seen as three different tabs in the program:

1. Input tab – Type in the general data and information about the motor and about the load. Try to use as accurate data as possible to get the most accurate results.
2. Calculation tab – Here it is possible to see how long the start will be depending on how high the current is. This tab will indicate which settings should be used and it might affect the selection.
3. The selection tab – Select which of the suggested softstarters to use. Here it is also possible to generate a report about the selection.

The softstarter selection tool can be downloaded from www.abb.com/lowvoltage by choosing Support "Online Product Selection Tools", Online Tools, Softstarters.



Softstarter selection

Coordination tables

Coordination is a combination of electrical apparatus which is safe for the surroundings and personnel, even if an overload or a fault should occur in the system. ABB's coordination tables are available for different combinations of products. The softstarter coordination tables are available with different protection devices (MMS, MCCB and semiconductor fuses), different coordination types (type 1 and type 2), different kA-ratings and for different connections (In-line and inside delta).

The coordination tables can be found on www.abb.com/lowvoltage by clicking "Online Product Selection Tools" and "Coordination Tables for motor protection".



Coordination tables

SoftstarterCare™ – Service Engineer Tool

The service engineer tool makes softstarter commissioning easier than it has ever been. With the tool, tuning of parameters can be made on a PC. By just plugging the PC to the softstarter, using ABB's cable (1SFA897201R1001), the parameter settings can be uploaded to the softstarter. This makes it very fast and easy to set up multiple PSE softstarters. Service Engineer Tool gives you:

- Access to all parameters on the HMI available on a PC
- Access to additional parameters that can't be reached from the HMI
- Access to the PSE event log
- PSE softstarter status information
- Trouble shooting form with pre-filled softstarter information
- Access to upgrade the softstarter firmware



SoftstarterCare 64bits













SoftstarterCare 32bits

Certifications and approvals

The table below shows the approvals and certifications for different softstarters.

For approvals and/or certificates not listed below, please contact your local ABB sales office.

Certifications and approvals

Abbreviation approved in	Certifications							Approvals: ship classification societies		
										
	CE EU	UL USA	cULus Canada USA	CSA Canada	CCC China	GOST Russia	ANCE Mexico	C-tick Australia	ABS American Bureau of Shipping	GL Germany
PSR3 ... PSR105	•	• ¹⁾	•	• ¹⁾	•	•	–	•	–	–
PSS18/30 ... PSS300/515	•	•	–	•	•	•	•	•	–	–
PSE18 ... PSE370	•	• ¹⁾	•	• ¹⁾	•	•	•	•	–	–
PST30 ... PSTB1050	•	• ¹⁾	•	• ¹⁾	•	•	•	•	•	•

• **Standard design approved**, the company labels bear the certification mark when this is required.

1) Covered by cULus certificate

Directives and standards

No. 2006/95/EC	Low voltage equipment
No. 2004/108/EC	Electromagnetic compability
EN 60947-1	Low-voltagesswitchgear and controlgear - Part 1: General rules
EN 60947-4-2	AC semiconductor motor controllers and starters
UL 508	Industrial Control Equipment
CSA C22.2 No 14	Industrial Control Equipment

Material available on www.abb.com/lowvoltage

The following material is a selection of all softstarter related material that is available on www.abb.com/lowvoltage. Just click on "Control Products", "Softstarters", "Softstarters".

- Product catalogs and brochures
- Certificates and approvals
- Circuit diagrams and application diagrams
- Dimension drawings (2D and 3D)
- Manuals
- eds- and gsd-files for fieldbus connection
- Softstarter selection tool



Contact us

ABB AB

Low Voltage Products

Control Products

SE-721 61 VÄSTERÅS, Sweden

Telephone +46 21 32 07 00

Fax +46 21 12 60 01

www.abb.com/lowvoltage

Note

We reserve the right to make technical changes or modify the contents of this document without prior notice. With regard to purchase orders, the agreed particulars shall prevail. ABB does not accept any responsibility whatsoever for potential errors or possible lack of information in this document.

We reserve all rights in this document and in the subject matter and illustrations contained therein. Any reproduction, disclosure to third parties or utilization of its contents - in whole or in parts - is forbidden without prior written consent of ABB.

Copyright© 2013 ABB
All rights reserved



To get more information, install QR code reader on your mobile device, scan the code and see more.