

ZEN Programmable Relays

Operation Manual

Produced March 2001

Notice:

OMRON products are manufactured for use according to proper procedures by a qualified operator and only for the purposes described in this manual.

The following conventions are used to indicate and classify precautions in this manual. Always heed the information provided with them. Failure to heed precautions can result in injury to people or damage to property.

 **DANGER** Indicates an imminently hazardous situation which, if not avoided, will result in death or serious injury.

 **WARNING** Indicates a potentially hazardous situation which, if not avoided, could result in death or serious injury.

 **Caution** Indicates a potentially hazardous situation which, if not avoided, may result in minor or moderate injury, or property damage.

OMRON Product References

All OMRON products are capitalized in this manual. The word “Unit” is also capitalized when it refers to an OMRON product, regardless of whether or not it appears in the proper name of the product.

Visual Aids

The following headings appear in the left column of the manual to help you locate different types of information.

Note Indicates information of particular interest for efficient and convenient operation of the product.

1,2,3... 1. Indicates lists of one sort or another, such as procedures, checklists, etc.

Precaution Indicates precautionary information that should be heeded in using the ZEN.



Indicates that the display (the word “LANGUAGE” in this case) is flashing. In this manual, this state is described by saying that the “flashing cursor” is at the word “LANGUAGE”. In this state it is possible to change settings and the position of the cursor.



Indicates that the display (the letter “H” in this case) is flashing in reverse video. In this manual, this state is described by saying that the “highlighted cursor” is at the word “H”. In this state it is not possible to change settings but the cursor can be changed to the flashing cursor by pressing the **OK** button.



Indicate the buttons that needs to be pressed in operating procedures. Press each button once.



Indicate buttons that needs to be pressed in operating procedures. Press one of the buttons once or more.

© OMRON, 2001

All rights reserved. No part of this publication may be reproduced, stored in a retrieval system, or transmitted, in any form, or by any means, mechanical, electronic, photocopying, recording, or otherwise, without the prior written permission of OMRON.

No patent liability is assumed with respect to the use of the information contained herein. Moreover, because OMRON is constantly striving to improve its high-quality products, the information contained in this manual is subject to change without notice. Every precaution has been taken in the preparation of this manual. Nevertheless, OMRON assumes no responsibility for errors or omissions. Neither is any liability assumed for damages resulting from the use of the information contained in this publication.

TABLE OF CONTENTS

PRECAUTIONSxi
1 Safety Precautions	xii
2 Application Precautions	xiii
3 Operating Environment Precautions	xvi
4 Conformance to EC Directives	xvi
5 Operating Mode at Startup.....	xix
6 Memory Backup.....	xx

SECTION 1

Outline	1
1-1 Outline	2
1-2 Features and Part Names	8
1-3 Display Screen and Basic Operations	13
1-4 Memory Areas	24
1-5 Allocating I/O Bit Numbers.....	26
1-6 Preparations for Operation.....	27

SECTION 2

Installation and Wiring29
2-1 Mounting	30
2-2 Wiring	31

SECTION 3

Programming and Operating Methods35
3-1 Selecting Display Language	36
3-2 Setting the Date and Time	37
3-3 Creating Ladder Programs	38
3-4 Confirming Ladder Program Operation.....	47
3-5 Correcting Ladder Programs	49
3-6 Using Timers (T) and Holding Timers (#).....	51
3-7 Using Counters (C)	54
3-8 Using Weekly Timers (@).....	56
3-9 Using Calendar Timers (*).	58
3-10 Analog Inputs (Analog Comparators (A)).....	60
3-11 Comparing Timer/Counter Present Values Using Comparators (P)	63
3-12 Displaying Messages (Display Bits (D))	66
3-13 Using Button Switches (B)	68

TABLE OF CONTENTS

SECTION 4

Special Functions	71
4-1 Protecting Programs	72
4-2 Stabilizing Input Operations	74
4-3 Changing Backlight Automatic Cutout Time	76
4-4 Adjusting LCD Screen Contrast	77
4-5 Setting Summertime	77
4-6 Reading System Information	78

SECTION 5

Optional Products	79
5-1 Mounting Battery Units	80
5-2 Using Memory Cassettes	81
5-3 Connecting the ZEN Support Software	83

SECTION 6

Troubleshooting	85
6-1 Troubleshooting	86
6-2 Error Messages	86
6-3 Deleting Error Messages	88

Appendices

A Product Configurations	89
B Specifications	91
C Ladder Program Execution	97
D Application Examples	99
E Allocations and Setting Sheets	113

Index	117
--------------------	------------

Revision History	121
-------------------------------	------------

About this Manual:

This manual describes the installation and operation of the ZEN Programmable Relays and includes the sections described below.

Please read this manual carefully and be sure you understand the information provided before attempting to install or operate the ZEN. Be sure to read the precautions provided in the following section.

Precautions provides general precautions for using the ZEN and related devices.

Section 1 gives an outline of the ZEN, including example applications, the system configurations and basic operations.

Section 2 explains how to mount and wire the ZEN CPU Units and Expansion I/O Units.

Section 3 explains how to create and edit ladder programs and how to use the timers, counters, comparators, display function and buttons switches.

Section 4 describes how to protect ladder programs, stabilize inputs, make LCD screen adjustments, and make summer time settings.

Section 5 describes how to mount Battery Units, use Memory Cassettes, and how to connect the ZEN Support Software.

Section 6 lists the error messages and provides probable causes and countermeasures for troubleshooting.

The following two manuals are provided for the ZEN Programmable Relays. Refer to them as required in operation.

Manual	Contents	Cat. No.
ZEN Programmable Relays Operation Manual	ZEN specifications, functions, and operating methods.	W385
ZEN Support Software Operation Manual	Installation and operating procedures for the ZEN Support Software	W386



WARNING Failure to read and understand the information provided in this manual may result in personal injury or death, damage to the product, or product failure. Please read each section in its entirety and be sure you understand the information provided in the section and related sections before attempting any of the procedures or operations given.

About this Manual

PRECAUTIONS

This section provides general precautions for using the ZEN Programmable Relays.

The information contained in this section is important for the safe and reliable application of the ZEN. You must read this section and understand the information contained before attempting to set up or operate a ZEN and ZEN.

1	Safety Precautions	xii
2	Application Precautions	xiii
2-1	Circuit Design and Ladder Programming	xiii
2-2	Installation	xiii
2-3	Wiring and Connections.	xiii
2-4	I/O Connections and Startup Precautions	xiv
2-5	Handling.	xiv
2-6	Maintenance.	xv
2-7	Transportation and Storage	xv
3	Operating Environment Precautions	xvi
4	Conformance to EC Directives	xvi
4-1	Applicable Directives.	xvi
4-2	Concepts.	xvi
4-3	Conformance to EC Directives	xvii
4-4	Relay Output Noise Reduction Methods	xvii
5	Operating Mode at Startup.	xix
6	Memory Backup.	xx

1 Safety Precautions

 **WARNING** Never attempt to disassemble any Units while power is being supplied. Doing so may result in serious electrical shock or electrocution.

 **WARNING** Never touch the I/O terminals, computer connector, Expansion Unit connector, or Battery Unit connector while power is being supplied. Doing so may result in serious electrical shock or electrocution.

 **WARNING** Provide safety measures in external circuits (i.e., not in the ZEN), including the following items, to ensure safety in the system if an abnormality occurs due to malfunction of the ZEN or another external factor affecting the ZEN operation. Not doing so may result in serious accidents.

- Emergency stop circuits, interlock circuits, limit circuits, and similar safety measures must be provided in external control circuits.
- The ZEN will turn OFF all outputs when its self-diagnosis function detects any error. As a countermeasure for such errors, external safety measures must be provided to ensure safety in the system.
- The ZEN outputs may remain ON or OFF due to deposition or burning of the output relays or destruction of the output transistors. As a countermeasure for such problems, external safety measures must be provided to ensure safety in the system.
- Provide double safety mechanisms to handle incorrect signals that can be generated by broken signal lines or momentary power interruptions.

 **WARNING** Do not short the battery terminals or charge, disassemble, heat, or incinerate the battery. Do not subject the battery to strong shocks. Doing any of these may result in leakage, rupture, heat generation, or ignition of the battery. Dispose of any battery that has been dropped on the floor or otherwise subjected to excessive shock. Batteries that have been subjected to shock may leak if they are used.

 **Caution** Tighten the AC power supply terminal block screws to the torque specified in the manual. Loose screws can result in fire or faulty operation.

2 Application Precautions

Observe the following precautions when using the ZEN or the ZEN.

2-1 Circuit Design and Ladder Programming

- Provide external interlock circuits, limit circuits, and other safety circuits in addition to any provided within the ZEN to ensure safety.
- The output relays may remain ON due to internal circuit faults or other reasons. As a countermeasure for such problems, external safety measures must be provided to ensure safety in the system.
- Always turn ON power to the ZEN before turning ON power to the I/O circuits. If the ZEN power supply is turned ON after the I/O power supply, temporary errors may result in operation.
- The life of the output relays is largely affected by the switching conditions. Confirm the operation of the system under actual operating conditions and set the switching frequency to ensure that adequate performance will be provided. Insulation faults and burning in the ZEN may result if relays are used after their performance as deteriorated.

2-2 Installation

- Install the ZEN according to instructions in the operation manuals. Improper installation may cause faulty operation.
- Do not install the ZEN in locations subject to excessive noise. Malfunction may occur.
- Do not allow the ZEN to fall during installation.
- Be sure that all the mounting screws on the ZEN and Expansion I/O Unit are tightened to the torque specified in the manual. Incorrect tightening torque may result in malfunction.
- Use with the cover of the computer connector mounted. Using without the cover may result in malfunction due to dust or other foreign matter.
- Be sure that the DIN rail mounting levers, Expansion I/O Units, Memory Cassettes, Battery Units, cable connectors, and other items with locking devices are properly locked into place. Improper locking may result in malfunction.

2-3 Wiring and Connections

- Use the wires specified in this manual when wiring. Use straight crimp terminals when connecting loose wires.

- Provide circuit breakers and other safety measures to provide protection against shorts in external wiring.
- Use separate wiring ducts for signal wires from those used for power supply and high-voltage lines.
- Always check polarity when connecting cables.
- Leave the label attached to the Unit when wiring. Removing the label may result in malfunction if foreign matter enters the Unit.
- Remove the label after the completion of wiring to ensure proper heat dissipation. Leaving the label attached may result in malfunction.
- Tighten the terminal block screws to the torque specified in the manual.
- Wire the ZEN according to instructions in the operation manuals. Improper installation may cause faulty operation.

2-4 I/O Connections and Startup Precautions

- Use the Units only with the power supplies and voltages specified in the operation manuals. Other power supplies and voltages may damage the Units.
- Take measures to stabilize the power supply to conform to the rated supply if it is not stable.
- Do not apply voltages exceeding the rated input voltage to input circuits. The input circuits may be destroyed.
- Do not apply voltages exceeding the maximum switching capacity to output circuits. The output circuits may be destroyed.
- Double-check all wiring before turning ON the power supply. Incorrect wiring may result in burning.
- Check the user program for proper execution before actually running it on the Unit. Not checking the program may result in an unexpected operation.

2-5 Handling

- Use, store, and transport the ZEN under the limits given for general specifications in this manual.
- Do not attempt to disassemble, repair, or modify any Units. Any attempt to do so may result in malfunction, fire, or electric shock.
- Always turn OFF the power supply to the ZEN before attempting any of the following.
 - Assembling the ZEN.
 - Attaching or removing the Expansion I/O Unit.
 - Connecting or disconnecting any cables or wiring.

- Attaching or removing the Memory Cassette.
- Attaching or removing the Battery Unit.
- Confirm that no adverse effect will occur in the system before attempting any of the following. Not doing so may result in an unexpected operation.
 - Changing the operating mode.
 - Using the button switches.
 - Changing bit status or parameter settings.
- Before touching a Unit, be sure to first touch a grounded metallic object in order to discharge any static build-up.
- Do not pull on the cables or bend the cables beyond their natural limit. Doing either of these may break the cables.
- Do not place objects on top of the cables or other wiring lines. Doing so may break the cables.
- Do not short the battery terminals or charge, disassemble, heat, or incinerate the battery. Do not subject the battery to strong shocks. Doing any of these may result in leakage, rupture, heat generation, or ignition of the battery. Dispose of any battery that has been dropped on the floor or otherwise subjected to excessive shock. Batteries that have been subjected to shock may leak if they are used.
- Abide by all local ordinances and regulations when disposing of the ZEN.

2-6 Maintenance

- When replacing parts, be sure to confirm that the rating of a new part is correct.
- When replacing a Unit, transfer to the new Unit and confirm all settings for clock data, internal holding bits, holding timers, and counter before starting operation again.

2-7 Transportation and Storage

- When transporting or storing the ZEN, wrap all circuit boards in conductive material and maintain the specified storage temperature to protect the LSIs and ICs from static electricity.
- Use special packaging boxes when transporting the ZEN and do not subject it to excessive shock or vibration or drop it during shipment.

- Store the ZEN in the following temperature and humidity ranges without condensation or icing.

Model	Ambient temperature	Humidity
LCD	-20 to 75°C	10% to 90%
LED	-40 to 75°C	

3 Operating Environment Precautions

Do not operate the control system in the following places.

- Where the ZEN is exposed to direct sunlight.
- Where the ambient temperature or humidity is beyond the specified ranges.
- Where the ZEN may be affected by condensation due to radical temperature changes.
- Where there is any corrosive or inflammable gas.
- Where there is excessive dust, saline air, or metal powder.
- Where the ZEN is affected by vibration or shock.
- Where any water, oil or chemical may splash on the ZEN.
- Any other place with conditions beyond those specified in the general specifications.

Take appropriate and sufficient countermeasures when installing systems in the following locations:

- Locations subject to static electricity or other forms of noise.
- Locations subject to strong electromagnetic fields.
- Locations subject to possible exposure to radioactivity.
- Locations close to power supplies.

4 Conformance to EC Directives

4-1 Applicable Directives

- EMC Directives
- Low Voltage Directive

4-2 Concepts

EMC Directives

OMRON devices that comply with EC Directives also conform to the related EMC standards so that they can be more easily

built into other devices or the overall machine. The actual products have been checked for conformity to EMC standards (see the following note). Whether the products conform to the standards in the system used by the customer, however, must be checked by the customer.

EMC-related performance of the OMRON devices that comply with EC Directives will vary depending on the configuration, wiring, and other conditions of the equipment or control panel on which the OMRON devices are installed. The customer must, therefore, perform the final check to confirm that devices and the overall machine conform to EMC standards.

Note Applicable EMC (Electromagnetic Compatibility) standards are as follows:

EMS (Electromagnetic Susceptibility): EN61000-6-2

EMI (Electromagnetic Interference): EN50081-2

(Radiated emission: 10-m regulations)

Low Voltage Directive

Always ensure that devices operating at voltages of 50 to 1,000 VAC and 75 to 1,500 VDC meet the required safety standards for the ZEN (EN61131-2).

4-3 Conformance to EC Directives

The ZEN complies with EC Directives. To ensure that the machine or device in which the ZEN is used complies with EC Directives, the ZEN must be installed as follows:

1,2,3...

1. The ZEN must be installed within a control panel.
2. You must use reinforced insulation or double insulation for the DC power supplies used for the communications power supply and I/O power supplies.
3. ZEN complying with EC Directives also conform to the Common Emission Standard (EN50081-2). Radiated emission characteristics (10-m regulations) may vary depending on the configuration of the control panel used, other devices connected to the control panel, wiring, and other conditions.

You must therefore confirm that the overall machine or equipment complies with EC Directives.

4-4 Relay Output Noise Reduction Methods

The ZEN conforms to the Common Emission Standards (EN50081-2) of the EMC Directives. However, noise generated by relay output switching may not satisfy these Standards. In such a case, a noise fil-

ter must be connected to the load side or other appropriate countermeasures must be provided external to the ZEN.

Countermeasures taken to satisfy the standards vary depending on the devices on the load side, wiring, configuration of machines, etc. Following are examples of countermeasures for reducing the generated noise.

Countermeasures

(Refer to EN50081-2 for more details.)

Countermeasures are not required if the frequency of load switching for the whole system with the ZEN included is less than 5 times per minute.

Countermeasures are required if the frequency of load switching for the whole system with the ZEN included is more than 5 times per minute.

Countermeasure Examples

When switching an inductive load, connect a surge protector, diodes, etc., in parallel with the load or contact as shown below.

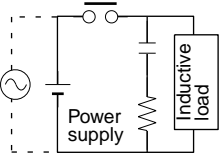
Circuit	Current		Characteristic	Required element
	AC	DC		
<p>CR method</p> 	Yes	Yes	<p>If the load is a relay or solenoid, there is a time lag between the moment the circuit is opened and the moment the load is reset.</p> <p>If the supply voltage is 24 or 48 V, insert the surge protector in parallel with the load. If the supply voltage is 100 to 200 V, insert the surge protector between the contacts.</p>	<p>The capacitance of the capacitor must be 1 to 0.5 μF per contact current of 1 A and resistance of the resistor must be 0.5 to 1 Ω per contact voltage of 1 V. These values, however, vary with the load and the characteristics of the relay. Decide these values from experiments, and take into consideration that the capacitance suppresses spark discharge when the contacts are separated and the resistance limits the current that flows into the load when the circuit is closed again.</p> <p>The dielectric strength of the capacitor must be 200 to 300 V. If the circuit is an AC circuit, use a capacitor with no polarity.</p>

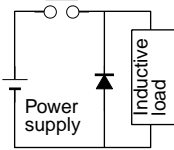
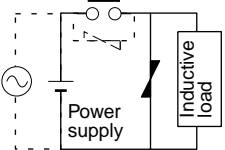
Circuit	Current		Characteristic	Required element
	AC	DC		
<p>Diode method</p> 	No	Yes	<p>The diode connected in parallel with the load changes energy accumulated by the coil into a current, which then flows into the coil so that the current will be converted into Joule heat by the resistance of the inductive load.</p> <p>This time lag, between the moment the circuit is opened and the moment the load is reset, caused by this method is longer than that caused by the CR method.</p>	<p>The reversed dielectric strength value of the diode must be at least 10 times as large as the circuit voltage value. The forward current of the diode must be the same as or larger than the load current.</p> <p>The reversed dielectric strength value of the diode may be two to three times larger than the supply voltage if the surge protector is applied to electronic circuits with low circuit voltages.</p>
<p>Varistor method</p> 	Yes	Yes	<p>The varistor method prevents the imposition of high voltage between the contacts by using the constant voltage characteristic of the varistor. There is time lag between the moment the circuit is opened and the moment the load is reset.</p> <p>If the supply voltage is 24 or 48 V, insert the varistor in parallel with the load. If the supply voltage is 100 to 200 V, insert the varistor between the contacts.</p>	---

5 Operating Mode at Startup

The operating mode at startup depends on the model and the presence of a user program as shown in the following table.

User program	In CPU	No	Yes	No	Yes
	In Memory Cassette	No	No	Yes	Yes
LCD model (with LCD and operation buttons)	STOP mode	RUN mode with program in CPU	RUN mode with program in Memory Cassette	RUN mode with program in CPU	RUN mode with program in CPU
LED model (with LED and no operation buttons)	STOP mode	RUN mode with program in CPU	RUN mode with program in Memory Cassette	RUN mode with program in CPU	RUN mode with program in CPU

6 Memory Backup

The ladder program and settings are stored in EEPROM and thus will not be lost even if the power supply is turned OFF for an extended period of time (e.g., 2 days at 25°C). The status of the following data, however, is backed up by an internal capacitor, and may be lost if power is turned OFF for an extended period of time: ON/OFF status of holding bits (H), holding timers (#), and counters (C) and the pre-vent value areas. For models equipped with a clock/calendar, the time and date may be reset. Always reconfirm system operation before restarting operation after the power has been turned OFF for an extended period of time. We recommend that a Battery Unit be (optional) connected in any system in which power may be interrupted for an extended period of time.

SECTION 1

Outline

This section gives an outline of the ZEN, including example applications, the system configurations and basic operations.

1-1	Outline	2
1-2	Features and Part Names	8
1-2-1	Features and System Configuration	8
1-2-2	Part Names	10
1-3	Display Screen and Basic Operations	13
1-3-1	Screens	15
1-3-2	Basic Operation	19
1-4	Memory Areas	24
1-5	Allocating I/O Bit Numbers	26
1-6	Preparations for Operation	27

1-1 Outline

The ZEN Programmable Relays is an extremely small programmable controller that provides 10 programmable I/O points (6 inputs and 4 outputs) to enable low-cost, small-scale automation. In this manual, the ZEN Programmable Relays is referred to as merely the "ZEN."

The ZEN comes in basically two types: LCD and LED.

- LCD Type: LCD screen and operation buttons
- LED Type: No LCD screen or operation buttons

The following pages provide a few examples of the way the ZEN meets a wide variety of application needs.

Low-cost, Small-scale Automatic Control

One CPU Unit provides 6 inputs and 4 outputs.

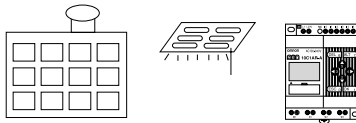

Water-supply facilities in apartments, lighting control in offices.

Easy Operation with an Inexpensive Controller

Ladder programming is possible directly from a LCD-type CPU Unit. Ladder programs can be easily copied to low-cost LED-type CPU Units by using Memory Cassettes (optional).

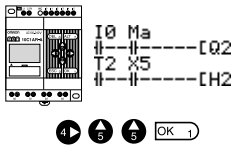

Smaller Control Panels

The ZEN is very small at 90 x 70 x 56 mm (H x W x D) and mounts essentially anywhere.

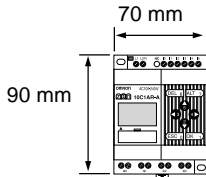

Less Assembly and Wiring Time Required for Control Panels

Simple one-touch DIN Track mounting. Built-in timers and counters so only power supply and I/O circuit wiring required.

Solid wires can be easily connected using only a screwdriver.

Refer to page 31.

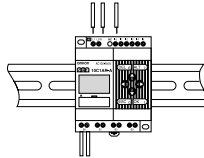

Future System Expandability

I/O capacity can be expanded to up to 18 inputs and 16 outputs by connecting 3 Expansion I/O Units.

Refer to page 31.

CPU Unit Expansion I/O Units (up to 3)

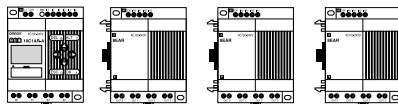

6 inputs/4outputs + (4 inputs/4outputs) × 3

Power Failure Countermeasures

EEPROM backs up the program and system settings data when no power is supplied to the ZEN.

Use a Battery Unit (optional) to back up work bits, holding timers, counters, and date/time data.

Refer to page 80.

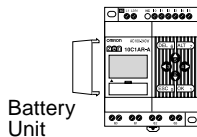

Easy Saving and Copying of Programs

Use an optional Memory Cassette to easily save and copy programs.

Refer to page 81.

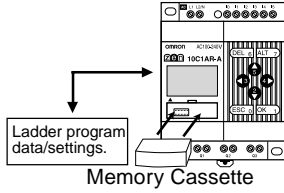

Programming and Monitoring from a Personal Computer

Windows-based ZEN Support Software is available.

Refer to page 83.

ZEN Support Software (CD-ROM)

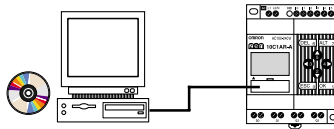

Greater Switching Capacity

The output contacts have 8-A switching capacity (250 VAC). All contacts are independent.

Refer to page 31.

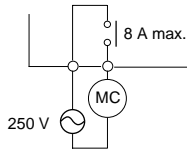

AC Inputs

For CPU Units with AC power supply inputs, 100 to 240 VAC can be directly connected.

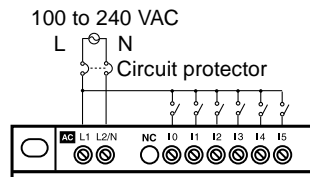

Easy Program Design

There are 4 different operations that can be set for bit outputs. Self-holding bits also can be easily programmed.

Refer to page 43.

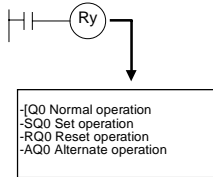

Complicated Timers without Additional Programming

Any of the 8 timers support 4 types of operation and 3 timing ranges.

There are also 4 built-in holding timers that hold data during power interruptions.

Refer to page 51.

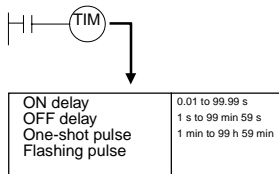

Incremental and Decremental Counters

There are 8 built-in counters that can be switched between incrementing and decrementing.

Use Comparators to enable programming multiple outputs from a counter.

Counters: Refer to page 54.

Comparators: Refer to page 63.

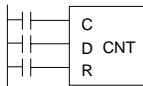

Control number of cars entering and leaving a car park.

Season- or Day-dependent Operating Times

CPU Units with built-in calendar and clock functions have 8 weekly timers and 8 calendar timers. Seasonal control is possible using calendar timers and day/time control is possible with weekly timers.

Weekly timers: Refer to page 56.

Calendar timers: Refer to page 58.

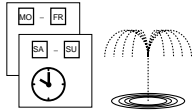

For gardens, parks, and recreational ponds.

Direct Analog Inputs

CPU Units with DC power supply inputs have 2 analog input points (0 to 10 V) and 4 analog comparators.

Refer to page 60.

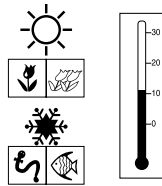

Temperature control for hot houses and tanks. Prevent freezing of swimming pools.

Easier Maintenance

Use the display function in LCD-type CPU Units to display user-set messages, the date, time, or other data. Button switches can also be used as input contacts. Applications include usage as a simple display operation panel.

Refer to page 66.

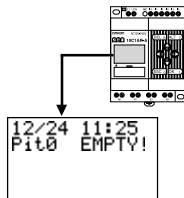

Longer Backlight for Dark Situations

The automatic cutout time for the backlight for LCD-type CPU Units can be set to 2, 10, or 30 minutes, or set to operate continuously. With the display function, the backlight can also be set to turn ON when a message is displayed.

Refer to page 76.

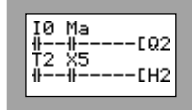

Prevent Chattering and Noise-related Malfunctions

Set the input filters to extend the filter timer and prevent malfunctions.

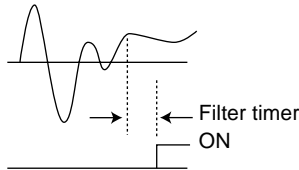

Exporting Systems Overseas

Display for LCD-type CPU Units is available in 6 languages. A Summertime function also supported.

Changing display language: Refer to page 36.

Summertime settings: Refer to page 77.

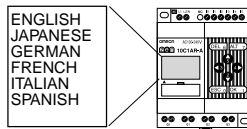

Programming Security

Programs can be protected by setting a password.

Refer to page 72.



1-2 Features and Part Names

1-2-1 Features and System Configuration

The ZEN is small but has a wide range of functions and is easy to use. The ZEN facilitates small-scale automatic control.

LCD-type CPU Unit Features

- Simple button-operated programming.
- Highly visible, backlit LCD.
- Adjustable automatic cutout time for the backlight.
- Adjustable contrast for the LCD screen.
- Six-language display.
- Display function for user-set messages (4 lines x 12 characters), time, or timer, counter, or analog-converted value displays.
- Button switches allowing operation buttons to be used as input contacts.
- Built-in weekly and calendar timers to allow simple seasonal or time-based operation.

LCD-type and LED-type CPU Unit Features

- Both 100 to 240-VAC and 24-VDC power supply models available.
- Built-in analog comparator for temperature control and other analog applications (provided on CPU Units with DC power supply inputs, two analog inputs IN4 and IN5, 0 to 10 V).
- Input filter settings to prevent noise-related malfunctions for both CPU Units and Expansion I/O Units.
- Program and settings data backed up on built-in EEPROM.
- Programming using ladder diagrams.
- Password function to protect programs.

Work bits, holding timer data, counter data, and date/time data will be backed up during long-term power supply interruptions if a Battery Unit (optional) is mounted.

ZEN-BAT01 Battery Unit

ZEN-ME01 Memory Cassette

Programs can be saved and copied by using a Memory Cassette (optional).

LCD/LED-type CPU Unit

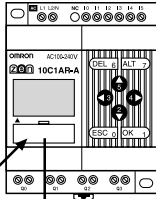

Up to 24 I/O points possible if Expansion I/O Units are connected.

Expansion I/O Units (up to 3 can be connected)

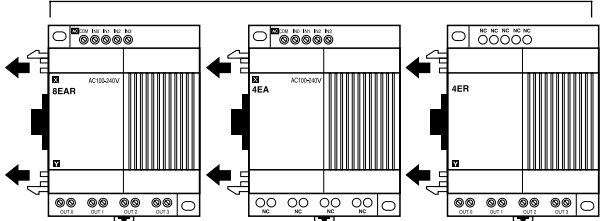

Personal computer connecting cable

Output relays have large a switching capacity (8A at 250 VAC). All 4 outputs have independent contacts.

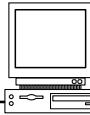

ZEN-SOFT01 ZEN Support Software



Programs can be created, edited, saved, and printed using the ZEN Support Software (optional).

1-2-2 Part Names

LCD-type CPU Units (with LCD and Operation Buttons)

Power supply	Inputs			Outputs	Input filter	Analog inputs	Calendar/time	Model number
100 to 240 VAC, 50/60 Hz	100 to 240 VAC	Not isolated	6	Relays	4	Yes	Yes	ZEN-10C1AR-A
24 VDC	24 VDC					Yes		ZEN-10C1DR-D

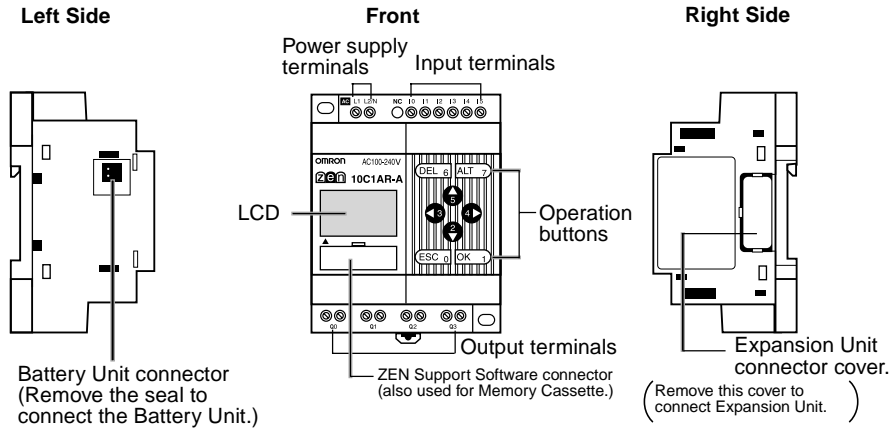

LED-type CPU Units (without LCD/Operation Buttons)

The ZEN is also available in an LED type that provide full operating functionality, but no direct programming input. The ZEN Support Software or a Memory Cassette containing a program is required.

Power supply	Inputs		Outputs	Input filters	Analog inputs	Calendar/time	Model number
100 to 240 VAC, 50/60 Hz	100 to 240 VAC	Not isolated	6 Relays	4	No		ZEN-10C2AR-A
24 VDC	24 VDC				Yes		ZEN-10C2DR-D

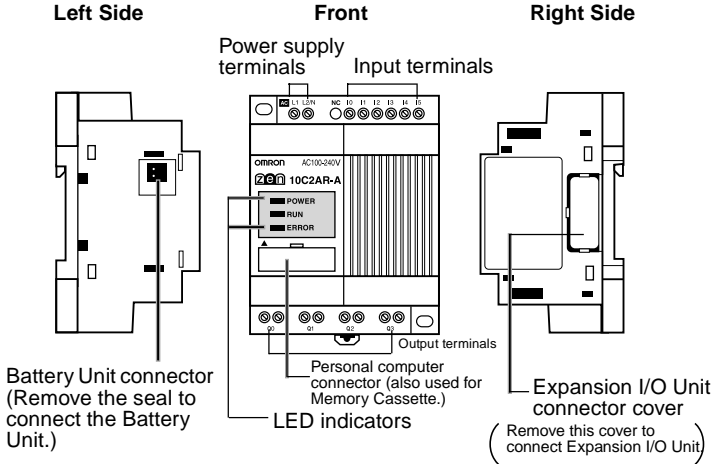

Indicators

Name	Color	Meaning	
POWER	Green	Lit	Power supplied
		Not lit	No power
RUN	Green	Lit	Operating (RUN)
		Not lit	Stopped (STOP)
ERROR	Red	Lit	Error
		Not lit	Normal

Differences between LCD- and LED-type CPU Units

Item		LCD type		LED type	
		AC power supply	DC power supply	AC power supply	DC power supply
Program editing, parameter settings, operation monitoring		Yes (Also possible with ZEN Support Software.)		Yes (ZEN Support Software required.)	
Operating mode switching		Yes (Also possible with ZEN Support Software)		Yes (ZEN Support Software required.)	
Calendar and clock function		Yes		No	
Bits	Input, output, work, holding bits	Yes		Yes	
	Timer, holding timer, counter	Yes		Yes	
	Weekly timer, calendar timer	Yes		No	
	Analog comparator	No	Yes	No	Yes
	Timer/counter comparator	Yes		Yes (ZEN Support Software required.)	
	Button switches	Yes		Yes	
	Display function	Yes		No	
Settings	Display language	Yes (Also possible with ZEN Support Software.)		-	
	Backlight cutout time	Yes (Also possible with ZEN Support Software.)		-	
	Input filters	Yes (Also possible with ZEN Support Software.)		Yes (ZEN Support Software required.)	
	Password	Yes (Also possible with ZEN Support Software.)		Yes (ZEN Support Software required.)	
Expansion I/O Unit connection		Yes		Yes	
Memory Cassette functions	ZEN to Memory Cassette transfer	Yes		No	
	Memory Cassette to ZEN transfer	Yes		Yes (Automatic transfer when power is turned ON.)	
	Memory Cassette initialization	Yes		No	
Battery Unit connection		Yes		Yes	
ZEN Support Software connection		Yes		Yes	

Expansion I/O Units

No. of I/O Points	Inputs			Outputs		Model
8 I/O	100 to 240 VAC, 50/60 Hz	Isolated	4	Relay	4	ZEN-8EAR
	24 VDC	Isolated	4	Relay	4	ZEN-8EDR
4 inputs	100 to 240 VAC, 50/60 Hz	Isolated	4	---	---	ZEN-4EA
	24 VDC	Isolated	4	---	---	ZEN-4ED
4 outputs	---	---	---	Relay	4	ZEN-4ER

Left Side

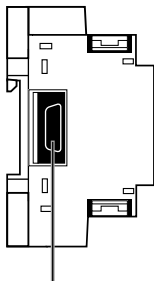

Expansion Unit connector

Front

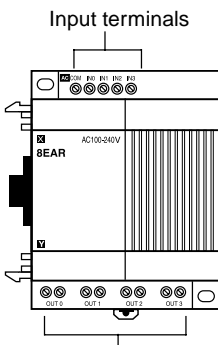

Output terminals

Right Side

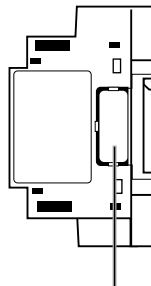

Expansion Unit connector cover.

(Remove this cover to connect Expansion I/O Unit.)

1-3 Display Screen and Basic Operations

The display screen for the LCD-type CPU Units and the operations of the buttons are shown below.

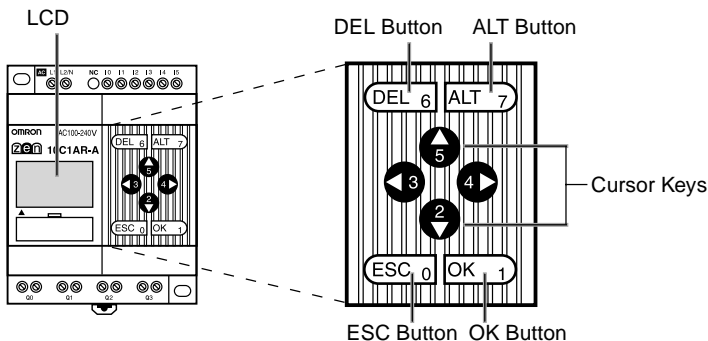

Icon Meanings



Icon	Meaning
RUN	Displayed while in RUN mode.
ERR	Indicates an error.
▲	Displayed when there is a higher-level menu or ladder program line than the one currently displayed.
▼	Displayed when there is a lower-level menu or ladder program line than the one currently displayed.
○	Displayed when a password has been set.

Operation Button Names and Operations

Button	Function			
	Menus	Writing ladder program	Setting parameters	Button switch (See68.)
DEL	---	Deletes inputs, outputs, connection lines, and blank lines.	---	B6 ON
ALT	---	Switches between normally open and normally closed conditions. Changes to connection line write mode. Inserts a line.	---	B7 ON
Up	Moves the cursor up and down.	Moves the cursor up and down. Selects bit types and functions.	Moves the cursor up and down.	B5 ON
Down			Changes numerals and parameters.	B2 ON
Left	---	Moves the cursor right and left.	Moves the cursor right and left.	B3 ON
Right				B4 ON
ESC	Returns to the previous screen.	Cancels the setting and returns to the previous operation.	Cancels the setting and returns to the previous operation.	B0 ON
OK	Selects the menu item at the cursor position.	Confirms the setting.	Confirms the setting.	B1 ON

1-3-1 Screens

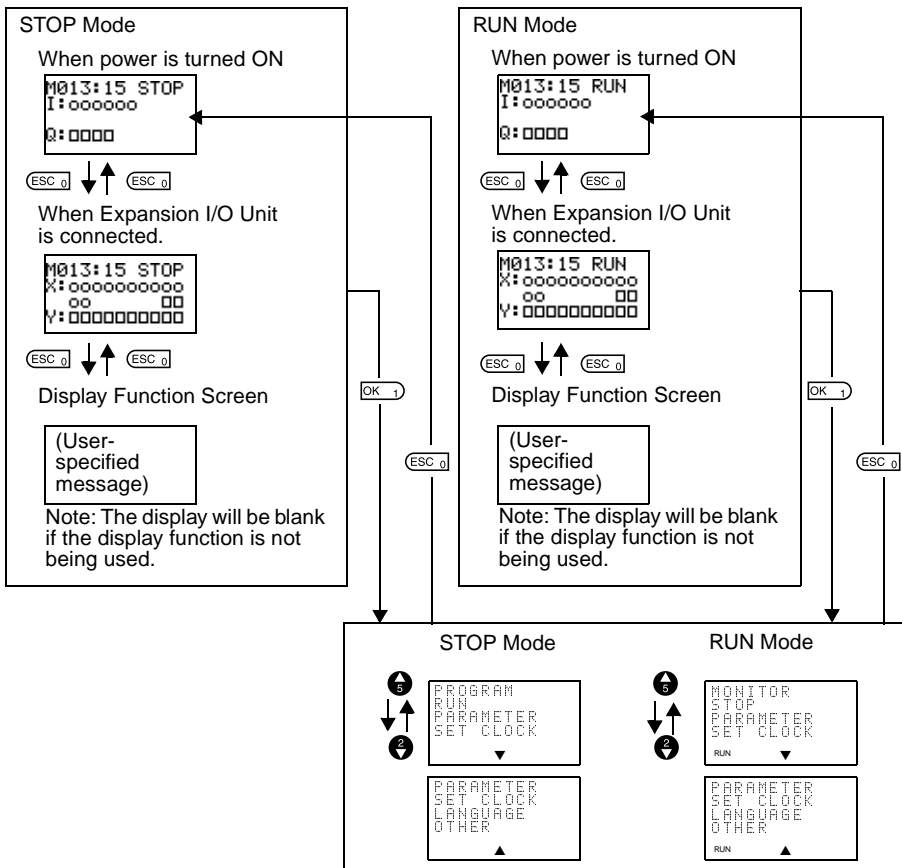

Display Screens

Main Screen

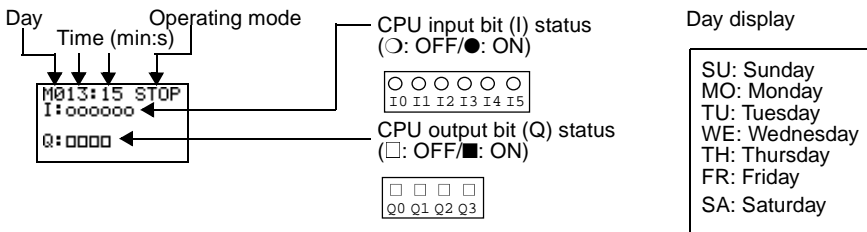

When One or More Expansion I/O Units Are Connected

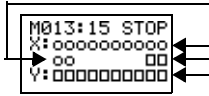

Expansion I/O Unit input bit (X) status
(○: OFF/●: ON)

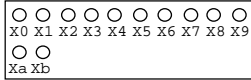

Note: The display depends on the number of input points on the connected Expansion I/O Units.

Expansion I/O Unit output bit (Y) status
(□: OFF/■: ON)

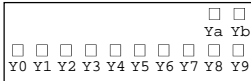

Note: The display depends on the number of output points on the connected Expansion I/O Units.

Menu Screen Configuration

RUN Mode

Ladder Monitor Screen

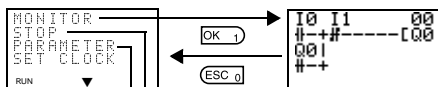

The ON/OFF status of input bits can be checked by monitoring the ladder program.

Switches to STOP mode.

The operation status of the timers, counters, and analog comparators can be monitored and the settings changed during operation. Refer to page 22.

STOP Mode

Ladder Program Edit Screen
(Refer to page 20.)

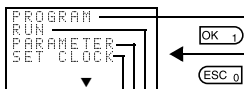

Creates and edits ladder program.

Deletes ladder program and parameters.

Memory Cassette Operation
(Refer to page 81.)

Transfers programs between ZEN and the Memory Cassette and initializes the Memory Cassette.

Note: Displayed only when a Memory Cassette is mounted.

Switches to RUN mode.

Changes the settings for timers, counters, and analog comparators.
(Refer to page 25.)

Date and Time Settings (Refer to page 37.)

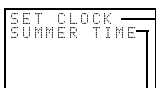
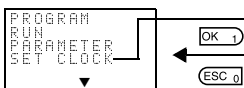

Sets the date and time.

Set when shipping to countries that use summer time. (Refer to page 77.)

Display Language Settings (Refer to page 36.)

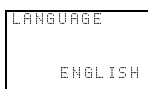
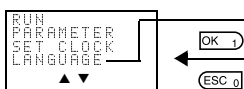

The display language can be changed. English, Japanese, German, French, Italian, and Spanish

Other Settings

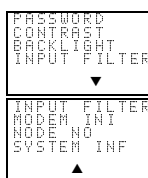
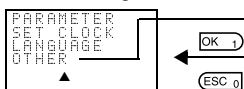

Other settings can be made. Refer to the following page for details.

Other Submenus

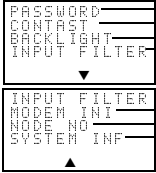

Setting Passwords (Refer to page 72.)



Set a password when you want to protect programs from being read. The password setting range is 0000 to 9999.

Adjusting Contrast (Refer to page 77.)



Adjust the contrast when the LCD screen is faint and difficult to read or when it is too dark to read. There are 5 contrast levels.

Changing Cutout Time for Backlight (Refer to page 76.)



Set the automatic cutout time for the backlight in the LCD screen.
2 min, 10 min, 30 min, Always ON

Setting Input Filters (Refer to page 74.)

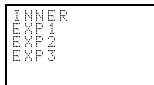

Set the input filters to ON or OFF for the CPU Unit or Expansion I/O Units. Set to ON when noise or chattering may affect operation.
"EXP1" to "EXP3" will be displayed depending on the number of Expansion I/O Units connected.

Do not use. For future system expansion.

Setting Node Number (Refer to page 83.)

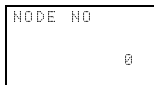

Set to the node number specified using the ZEN Support Software.

Reading System Information (Refer to page 78.)

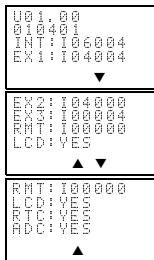

Read system information, such as the CPU Unit software version or the date it was created, the number of I/O points on the CPU Unit or the Expansion I/O Units, and whether or not LCD, RTC, or analog input functions are supported.

1-3-2 Basic Operation

Menu Selection Example

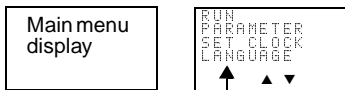

Flashing cursor

Use the **Up/Down** Buttons to move the cursor.



Highlighted cursor

Press the **OK** Button to select the flashing menu. The settings will flash on a reversed display.

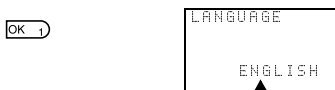

Flashing cursor

Press the **OK** Button to change from a highlighted cursor to a flashing cursor. Settings can now be changed.

Use the **Up/Down** Buttons to change the setting.



Use the **Up** Button to select **GERMAN**.



A confirmation message will be displayed asking if you want to change to German display.



Press the **OK** Button to change from English to German.



Press the **ESC** Button to cancel the change and return to the previous screen.

Example Operation in the Ladder Program Edit Screen

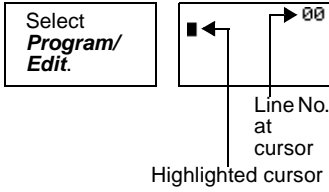

The highlighted cursor will appear in the initial write position. During highlighted cursor display, the cursor can be moved to the input or output write positions.

Up/Down Buttons: Move the highlighted cursor up and down.

Left/Right Buttons: Move the highlighted cursor Left/Right.

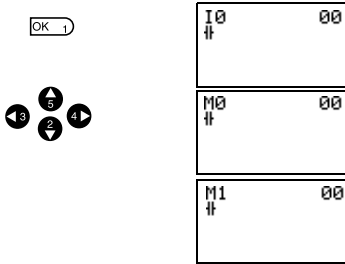

Press the **OK** Button at the input write position to display the input default setting IO and the normally open condition symbol. "I" will flash.

- **Flashing Cursor at the I Position**
 Up/Down Buttons: Change the bit type.
 Right Button: Moves the flashing cursor to the right.
 OK Button: Sets the bit type and moves the flashing cursor to the bit address position.
- **Flashing Cursor at the 0 Position**
 Up/Down Buttons: Change the bit address.
 OK Button: Completes the writing of the bit.
- **Switching between Normally Open and Normally Closed Conditions**
 You can use the ALT Button to switch between the N.O. and N.C. conditions, regardless of the position of the flashing cursor.

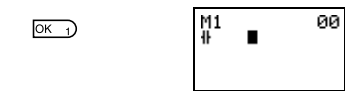

When the first input has been written, the highlighted cursor moves to the next input position.

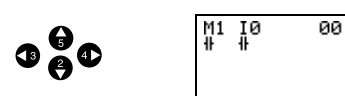

Use the above procedure to enter program input conditions in series.

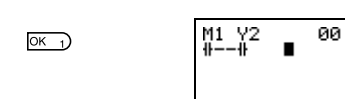

When writing serial inputs, the connecting line between inputs is drawn automatically.

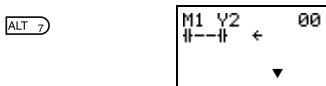

Press the **ALT** Button with the highlighted cursor in the input writing position to change the cursor to a flashing left arrow to enable connecting lines to be drawn.

Up/Down Buttons: Draw vertical connecting lines.

Left/Right Buttons: Draw horizontal connecting lines.

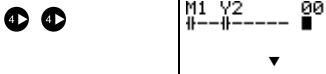

Press the **Right** Button twice to draw a line to the output bit. The cursor will change to a highlighted cursor at the output bit write position.

Press the **OK** Button at the output bit write position to display the default output Q0. Q will flash.

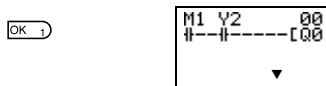

- Flashing Cursor at the Q (Bit Type) Position

Up/Down Buttons: Change the type of output

Right/Left Buttons: Move the flashing cursor.

OK Button: Sets the bit type and moves the flashing cursor to the bit address position.

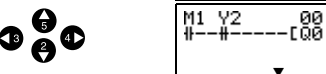

- Flashing Cursor at the [(Additional Output Function) Position

Up/Down Buttons: Selects the additional output function

OK Button: Sets the additional output function and moves the flashing cursor to the bit address position.

- Flashing Cursor at the 0 (Bit Address) Position

Up/Down Buttons: Select the bit address

OK Button: Completes the output write.

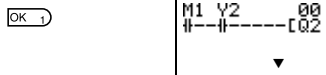

Press the **OK** Button to complete the bit write and to move the highlighted cursor to the first input position ON the next line.



Press the **ESC** Button to complete the writing of the ladder program and to return to the menu screen.



Example Parameter Settings Screen Operation

Select **Parameters** on menu screen.

T0	X	S	A
TRG			
RES			10.00

When *Parameter* is selected, the parameter settings are displayed.

(1) Selecting Parameters to Display

T0	X	S	A
TRG			
RES			00.01

Press the **OK** Button to change the highlighted cursor to a flashing cursor.

/

T1	X	S	A
TRG			
RES			00.01

Use the **Up/Down** Buttons to select another timer.

T1	X	S	A
TRG			
RES			00.01

When multiple parameters of the same type have been selected, use the **Up/Down** Buttons to scroll through the numbers.

/

C0			A
CNT			
RES			1500
DIR			

Press the **Left** Button to switch to another type, move the flashing cursor to the bit type position and use the **Up/Down** Buttons to select the bit type.

Move the flashing cursor to the bit type position and use the **Up/Down** Buttons to select another bit type.

(2) Setting and Changing Parameters

T0	X	S	A
TRG			
RES			10.00

T0	X	S	A
TRG			
RES			10.00

Use the **Left/Right** Buttons to move the highlighted cursor to the parameter to be set.

T0	X	S	A
TRG			
RES			10.00

Press the **OK** Button to confirm the set position. The cursor will change to a flashing cursor.

/

T0	X	M:S	A
TRG			
RES			10.00

Use the **Up/Down** Buttons to set the parameter.



```
T0 X M:S A
TRG
RES 10.00
```

Press the **OK** Button to confirm the setting.



```
T0 X M:S A
TRG
RES 10.00
```

Use the **Left/Right** or **Up/Down** Buttons to move the highlighted cursor to the parameter to be set.



```
T0 X M:S A
TRG
RES 10.00
```

Press the **OK** Button to confirm the set position. The cursor will change to a flashing cursor.



```
T0 X M:S A
TRG
RES 12.34
```

Use the **Left/Right** Buttons to select the digit to be set.

Use the **Up/Down** Buttons to change the value of each digit.



```
T0 X M:S A
TRG
RES 12.34
```

.Press the **OK** Button to confirm the setting.



Press the **ESC** Button to complete the settings.

Note If the ESC Button is pressed while ladder program or parameter settings are being input, the input to that point will be canceled and the settings will return to the original settings.

1-4 Memory Areas

I/O, Work, and Internal Holding Bits

Name	Sym- bol	Bit addresses	No. of bits	Function	Ladder programs	Page
CPU Unit input bits	I	I0 to I5	6	Reflect the ON/OFF status of the input devices connected to the CPU Unit input terminals.	N.O./N.C. inputs	26
Expan- sion I/O Unit input bits	X	X0 to Xb	12	Reflect the ON/OFF status of the input devices connected to the Expansion I/O Unit input terminals.		26
Button switches	B	B0 to B7	8	Turn ON when the operation buttons are pressed in RUN mode. Can only be used for LCD-type CPU Units.		68
Analog compara- tor bits	A	A0 to A3	4	Output the comparison result for analog inputs. Can only be used for models with a 24-VDC power supply.		60
Compara- tor bits	P	P0 to Pf	16	Compare the present value of timers (T), holding timers (#), and counters (C), and outputs the comparison result.		63
CPU Unit output bits	Q	Q0 to Q3	4	Output the ON/OFF status of the output bits to the outputs devices connected to the CPU Unit.	N.O./N.C. inputs Outputs (See note.)	26
Expan- sion I/O Unit out- put bits	Y	Y0 to Yf	12	Output the ON/OFF status of the output bits to the outputs devices connected to the Expansion I/O Unit.		26
Work bits	M	M0 to Mf	16	Can only be used within the program. Cannot output to an external device.		-
Holding bits	H	H0 to Hf	16	Same as for work bits however the holding bits maintain ON/OFF status when power is turned OFF.		-

Note The following additional functions can be selected for bit outputs.

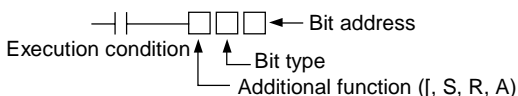

I	Normal output	Turns ON or OFF according to the ON/OFF status of the execution condition.
S	Set	Holds ON status after the execution condition turns ON once.

R	Reset	Holds OFF status after the execution condition turns ON once.
A	Alternate	Alternates between ON and OFF whenever the execution condition turns ON (input latch operation).

Timers and Counters

Name	Symbol	Bit addresses	No. of timers/counters	Function	Use in ladder programs	Page
Timer	T	T0 to T7	8	Can be switched between ON delay, OFF delay, one-shot, and flashing pulse operation. (See note.)	N.O./N.C. condition	51
Holding timer	#	#0 to #3	4	Holds the present value during counting even if the trigger input or power supply is turned OFF. Continues the timing when the trigger input or power supply is turned ON again.		51
Counter	C	C0 to C7	8	Reversible counters that can be incremented and decremented.		54
Weekly timer	@	@0 to @7	8	Can turn ON or OFF during a specified day or time period.		56
Calendar timer	*	*0 to *7	8	Can turn ON or OFF during a specified date period.		58

Note Timers can switch between operations. Refer to page 43.

X	ON delay	Times down while the trigger input is ON and turns ON the timer bit when the set time is reached.
■	OFF delay	Turns ON the timer bit while the trigger input is ON, starts timing down when the trigger input turns OFF, and turns OFF the timer bit when the set time is reached.
O	One-shot	Turns ON the timer bit for the set period when the trigger input changes from OFF to ON only.
F	Flashing pulse	Timer bit repeatedly turns ON/OFF at set intervals while the trigger input is ON.

Display Bits

Name	Symbol	Bit addresses	No. of bits	Function	Use in ladder programs	Page
Display	D	D0 to D7	8	Display user-set character strings, times, timer present values, counter present values, or analog-converted values.	Output	66

1-5 Allocating I/O Bit Numbers

The input bit addresses I0 to I5 and output bit addresses Q0 to Q3 are always allocated to the CPU Unit.

Up to 3 Expansion I/O Units can be added and input bit addresses X0 to Xb and output bit addresses Y0 to Yb are allocated in the order the Units are connected.

Connection Example for 4-point Expansion Input Unit, 4-point Expansion Output Unit, and 8-point Expansion I/O Unit

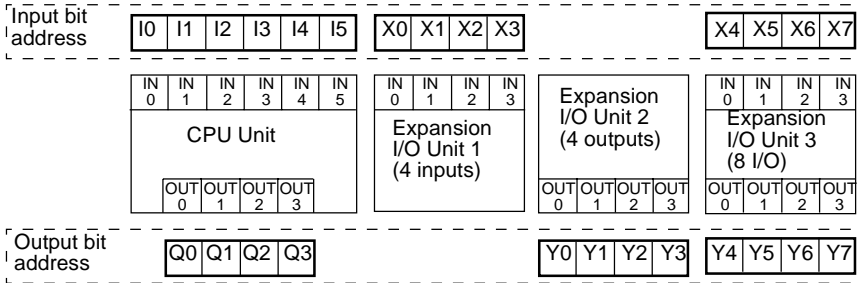

Note When an Expansion I/O Unit that does not have both inputs and outputs, such as the 4-point Input Unit and the 4-point Output Unit shown in the above diagram, the unused bit addresses are not allocated to that Unit and are used for the next Unit.

1-6 Preparations for Operation

Mount ZEN to Control Panels

The ZEN can be mounted to either a DIN Track or directly onto the surface of the control panel. Refer to page 30.

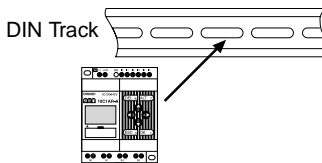

Connect Power Supply, Input, and Output Devices

Wire the ZEN to the power supply, input, and output devices. Refer to page 31.

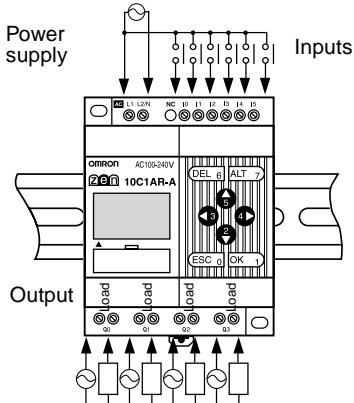

Make Initial Settings

Make the settings required before programming, such as date, time, and display language. Refer to pages 36 and 37.



Write Program

Input the ladder program, including timers, counters, and other parameters. Use the ZEN Support Software when using the LED-type CPU Units (without LCD or operation buttons.) Refer to page 38.

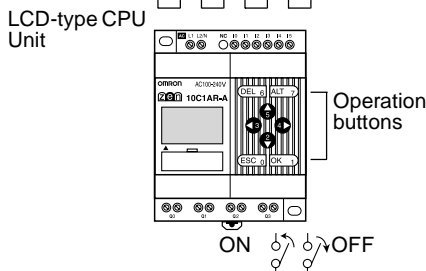

Check Program Execution

Perform trial operation before starting actual operation and check that the system is operating correctly. Refer to page 47.

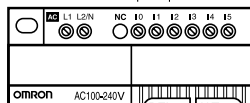

Save Program

Debugged programs and all parameters should be saved to a Memory Cassette or ZEN Support Software to prevent loss of the data. Refer to page 81.

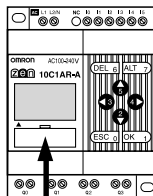

Actual Operation

ZEN-ME01 Memory Cassette

SECTION 2

Installation and Wiring

This section explains how to mount and wire the ZEN CPU Units and Expansion I/O Units.

2-1	Mounting	30
2-1-1	Installation Method	30
2-1-2	Connecting Expansion I/O Units	31
2-2	Wiring	31

2-1 Mounting

2-1-1 Installation Method

Always mount the ZEN inside a control panel.

The ZEN can either be mounted to the surface of the control panel or onto DIN Track.

Orientation

Do not mount the ZEN in any orientation other than shown in the diagram.

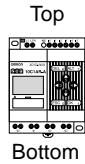

Mounting to DIN Track

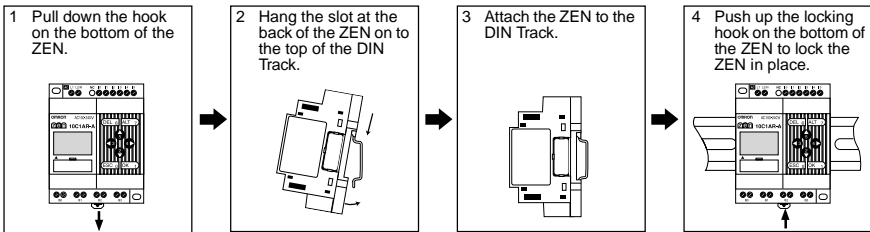

Mounting Inside a Control Panel

Use M4 screws to mount the ZEN.

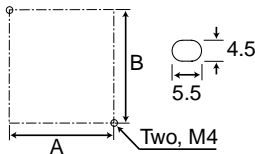

Mounting Dimensions (Unit: mm)

Unit	A	B
CPU Unit	60	80
4-point Expansion Input or 4-point Expansion Output Unit		
8-point Expansion I/O Unit		

2-1-2 Connecting Expansion I/O Units

Up to 3 Expansion I/O Units can be connected.

1 Remove the Expansion Unit connector cover on the side of the CPU Unit.

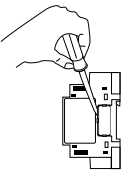

Insert a flat-blade screwdriver or similar tool and remove the cover.

2 Line up the connectors on the Expansion I/O Unit with the connectors on the CPU Unit and join.

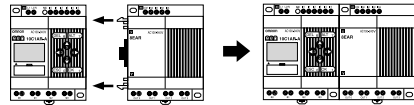

Make sure the connectors are lined up and push the Expansion I/O Unit and the CPU Unit together.

- Note**
1. Do not remove the Expansion Unit connector cover on the right edge of the connected Expansion Unit.
 2. Be careful when inserting the screwdriver that you do not insert it too far and damage the base or the elements.

2-2 Wiring

Connectable Wires

- A terminal block designed for solid wires is used. Use solid wires when wiring.

	Solid wires	Stranded wires	Straight terminals
One-line connection	0.2 to 2.5 mm ²	0.2 to 2.5 mm ² (Equivalent to AWG 24 to 14.)	0.25 to 2.5 mm ²
Two-line connection	0.2 to 0.75 mm ²	0.2 to 0.75 mm ² (Equivalent to AWG 24 to 19)	0.25 to 0.75 mm ²

- Strip the sheath back 6.5 mm.

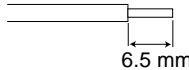

- Twisted wires can cause shorts so never directly connect twisted wires. Always connect a straight crimp terminal if using twisted wires.

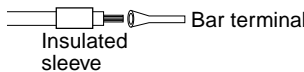

- Use a flat-blade screwdriver to tighten the terminal block.
- Tighten the terminal block to a torque of 0.5 to 0.6 N·m.

Wiring Power Supply and Input Lines

AC Power Supplies

Caution Do not connect the isolated side (L) and the grounded side (N) in reverse. Wire the L side to the AC input circuit.

100 to 240 VAC, 50/60 Hz, 30 VA

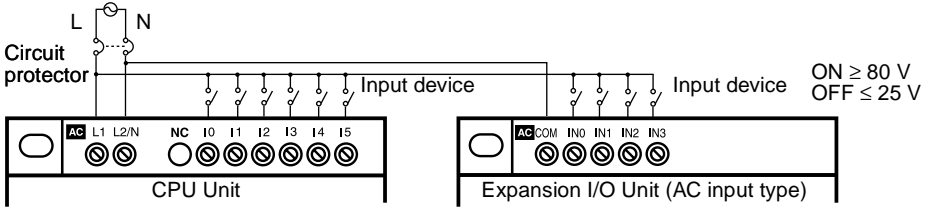

- Note**
1. A two-wire sensor cannot be connected directly to the AC input.
 2. Observe the power supply polarity when wiring the power supply and the input circuits. The input signals cannot be read if the polarity is incorrect.
 3. There are no restrictions on the polarity of the I/O on the Expansion I/O Units.
 4. Include a circuit protector or breaker for the ZEN in the power supply circuit.

DC Power Supplies

24 VDC, 6.5 W

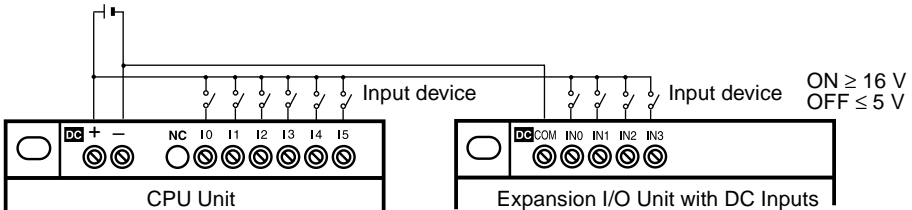

I4 and I5 can also be used for analog inputs. The input range is 0 to 10 V.

- Note**
1. Do not connect the + and - DC power supply in reverse for the DC power supply on the CPU Unit.
 2. Wire the positive side to the input circuit. The negative pole for the power supply circuit and the common for the input circuit are connected internally; the input circuit will not operate if the polarity is incorrect.

3. There are no restrictions on the polarity of the I/O on the Expansion I/O Unit.
4. Do not input a negative (-) signal to the analog inputs (I4, I5). The internal elements may be damaged if a negative signal is input.

Wiring Output Circuits

All 4 outputs in the output circuits have independent contacts. There are no particular restrictions on polarity.

Wiring CPU Units and Expansion I/O Units

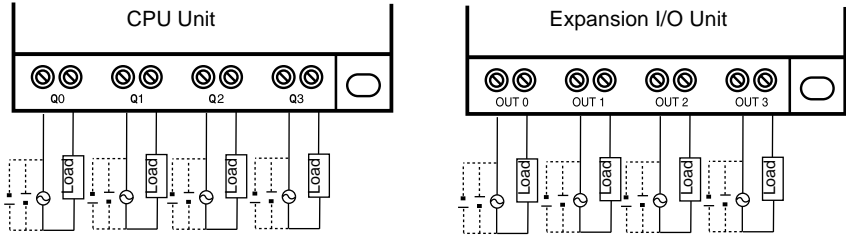

250 VAC, 8 A (cosφ = 1)
 24 VDC, 5 A

SECTION 3

Programming and Operating Methods

This section explains how to create and edit ladder programs and how to use the timers, counters, comparators, display function and buttons switches.

3-1	Selecting Display Language	36
3-2	Setting the Date and Time	37
3-3	Creating Ladder Programs	38
3-3-1	I/O Wiring and Internal Operation	38
3-3-2	Clearing Programs	39
3-3-3	Writing Ladder Programs	39
3-4	Confirming Ladder Program Operation	47
3-5	Correcting Ladder Programs	49
3-5-1	Changing Inputs	49
3-5-2	Changing Additional Bit Output Functions	49
3-5-3	Deleting Inputs, Outputs, and Connection Lines	50
3-5-4	Inserting Lines	50
3-5-5	Deleting Blank Lines	51
3-6	Using Timers (T) and Holding Timers (#)	51
3-6-1	Settings in the Ladder Program Edit Screen	53
3-6-2	Settings in the Parameter Settings Screen	53
3-6-3	Parameter Monitor Screen Display	54
3-7	Using Counters (C)	54
3-7-1	Settings in the Ladder Program Edit Screen	55
3-7-2	Settings in the Parameter Settings Screen	56
3-7-3	Parameter Monitor Screen Display	56
3-8	Using Weekly Timers (@)	56
3-8-1	Settings in the Ladder Program Edit Screen	57
3-8-2	Settings in the Parameter Settings Screen	57
3-8-3	Parameter Monitor Screen Display	58
3-9	Using Calendar Timers (*)	58
3-9-1	Settings in the Ladder Program Edit Screen	59
3-9-2	Settings in the Parameter Settings Screen	59
3-9-3	Parameter Monitor Screen Display	60
3-10	Analog Inputs (Analog Comparators (A))	60
3-10-1	Settings in the Ladder Program Edit Screen	61
3-10-2	Settings in the Parameter Settings Screen	62
3-10-3	Parameter Monitor Screen Display	62
3-11	Comparing Timer/Counter Present Values Using Comparators (P)	63
3-11-1	Settings in the Ladder Program Edit Screen	63
3-11-2	Settings in the Parameter Settings Screen	64
3-11-3	Parameter Monitor Screen Display	65
3-12	Displaying Messages (Display Bits (D))	66
3-12-1	Settings in the Ladder Program Edit Screen	66
3-12-2	Settings in the Parameter Settings Screen	67
3-13	Using Button Switches (B)	68

3-1 Selecting Display Language

There is a choice of 6 display languages for LCD-type CPU Units. The default language is English.

Operation to Select German

Turn ON the power.

```
M013:15 STOP
I:oooooo
Q:oooo
```

OK →

```
PROGRAM
RUN
PARAMETER
SET CLOCK
▼
```

Press the **OK** Button to change to the Menu Screen.

⬇ ⬇ ⬇ ⬇

```
RUN
PARAMETER
SET CLOCK
LANGUAGE
▲▼
```

Press the **Down** Button 4 times to move the cursor to "LANGUAGE".

OK →

```
LANGUAGE
ENGLISH
```

Press the **OK** Button to display the current language ("ENGLISH"). The final "H" will be highlighted and flashing.

OK →

```
LANGUAGE
ENGLISH
```

Press the **OK** Button to make the whole word "ENGLISH" flash. A different language can now be selected.

Use the **Up/Down** Buttons to select a language.

```

⬇
SPANISH
↓
ITALIAN
FRENCH
GERMAN
↑
JAPANESE
⬆
ENGLISH
```

⬆ ⬆

```
LANGUAGE
GERMAN
```

Press the **Up** Button to select **GERMAN**.

OK →

```
LANGUAGE
SET?
OK/ESC GERMAN
```

Press the **OK** Button to display a confirmation message.

Press **OK** to set the new language.

OK →

```
RUN
PARAMETER
KALENDER
SPRACHE
▲▼
```

The display language will change to German.

Press the **OK** Button to complete the setting.

3-2 Setting the Date and Time

The date and time are not set when the product is shipped. The date and time must be set for models with calendar and time functions before the ZEN can be used.

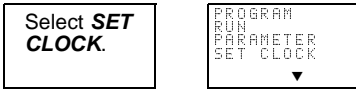

OK →



Press the **OK** Button to display the submenu for clock settings. Select **SET CLOCK** from the submenu.

OK →

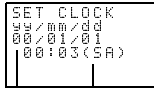

Press the **OK** Button to display the current date and time settings. The right digit of the date will be highlighted and flashing.

Current date: yy/mm/dd

Current time: hh:mm (day)

OK →



Set the date and time.

Use the **Up/Down** Buttons to change the setting.

Use the **Left/Right** Buttons to move the cursor.

The day will automatically change when the date is set.

Press the **OK** Button to display a confirmation message.

OK →



OK →

Press the **OK** Button to confirm and complete the setting.



Caution If the power supply is turned OFF for an extended period of time (2 days or more at 25°C), the date and time will return to the default setting (00/1/1; 00:00 (SA)).

- Note**
1. The year can be set between 2000 and 2099.
 2. If Summertime is set, "S" will appear at the top right of the time setting screen during the Summertime period.

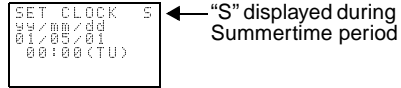

3-3 Creating Ladder Programs

Example Program

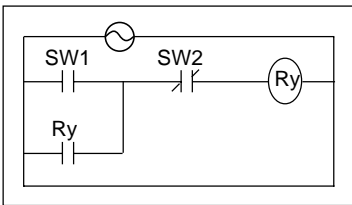

This section explains how to write ladder programs for LCD-type CPU Units, based on a simple circuit example.

Refer to the *ZEN-SOFT01 ZEN Support Software Operation Manual (W386)* for information on programming LED-type CPU Units.

3-3-1 I/O Wiring and Internal Operation

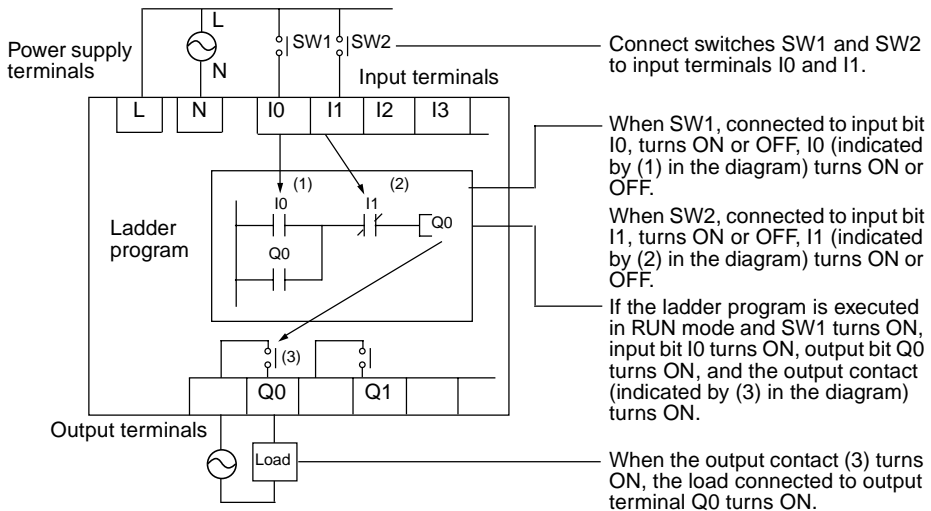

3-3-2 Clearing Programs

Clear the ladder program before starting to write a program. By performing the Delete Program operation, the ladder program will be completely cleared. The display language, date/time settings, and all other settings will not be initialized.

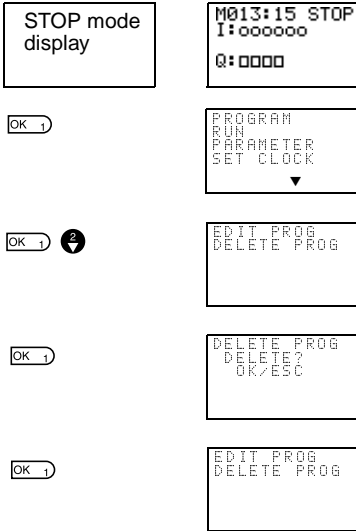

Press the **OK** Button to switch to the Menu Screen and select **PROGRAM**.

Select **DELETE PROG**.

Press the **OK** Button to display a confirmation message.

When the Delete Program operation has been completed, the display will return to the original screen.

3-3-3 Writing Ladder Programs

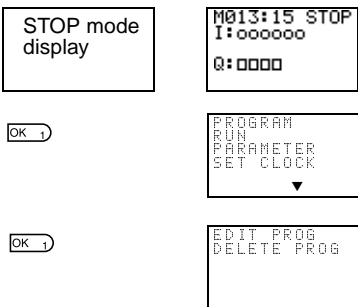

Press the **OK** Button to switch to the Menu Screen and select **PROGRAM**.

Select **EDIT PROGRAM**.

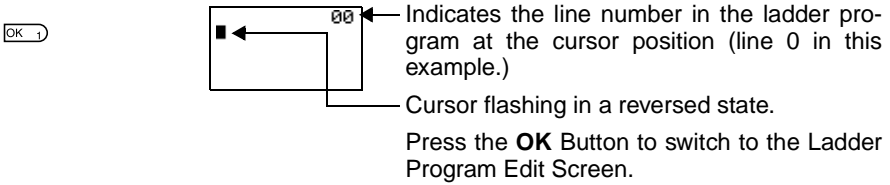

Operations in the Ladder Program Edit Screen

Two lines of circuits can be displayed at one time on the Ladder Program Edit Screen.

- Up to 96 lines can be written.
- Up to 3 inputs and 1 output can be written per line.

- Example ladder diagram

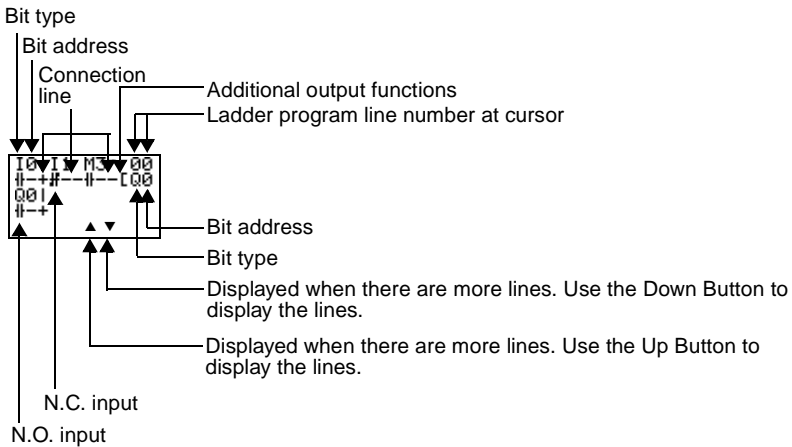

Positions for Writing Inputs, Outputs, and Connection Lines

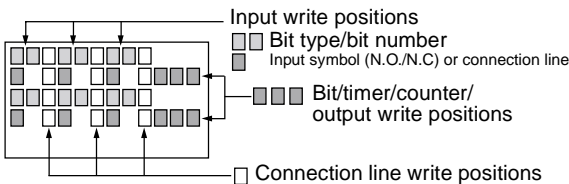

3-3-3-1 Writing an Input for I0



Press the **OK** Button to display the initial write setting (N.O input I0) and move the flashing cursor to the bit type I position. Use the **Up/Down** Buttons to select the bit type. Use the **Right** Button to move the flashing cursor to the 0 position and then use the **Up/Down** Buttons to select the bit address.

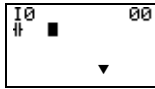
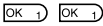

Press the **OK** Button twice to complete the write operation for input I0. The highlighted cursor will move the next input position.

3-3-3-2 Writing Serial Input I1

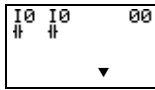

Press the **OK** Button to display the N.O. input and input I0 again.

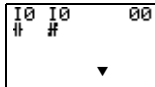

Press the **ALT** Button to switch to a N.C. input.

(Press the **ALT** Button again to switch back to a N.O. input.)

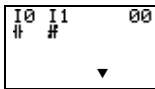

Use the **Right** Button to move the flashing cursor to the bit address position and use the **Up** Button to change the bit address to 1.

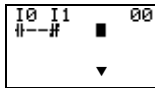

Press the **OK** Button to move the highlighted cursor to the next input position. A connection will automatically be created between input I0 and the next input.

Writing Inputs

Input Symbol Configuration

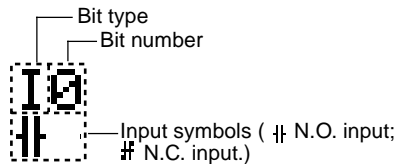

■ Memory Areas

Symbol	Name	Bit type and number
I	CPU Unit input bits	I0 to I5 (6 points)
Q	CPU Unit output bits	Q0 to Q3 (4 points)
X	Expansion I/O Unit input bits	X0 to Xb (12 points) (See note 1.)
Y	Expansion I/O Unit output bits	Y0 to Yb (12 points) (See note 1.)
M	Work bits	M0 to Mf (16 points)
H	Holding bits	H0 to Hf (16 points)
B	Button switches	B0 to B7 (8 points) (See note 2.)

- Note**
1. Can be used only when Expansion I/O Units are connected.
 2. Can be used only when LCD-type CPU Units are used.

■ Timers, Counters, and Analog Comparators

Symbol	Name	Bit type and number
T	Timers	T0 to T7 (8 timers)
#	Holding timers	#0 to #3 (4 timers)
@	Weekly timers	@0 to @7 (8 timers) (See note 1.)
*	Calendar timers	*0 to *7 (8 timers) (See note 1.)
C	Counters	C0 to C7 (8 counter)
A	Analog comparators	A0 to A3 (4 comparators) (See note 2.)
P	Comparators	P0 to Pf (16 comparators)

- Note**
1. Can be used only with CPU Units with calendar and clock functions.
 2. Can be used only with CPU Units with DC power supply.

ALT 7

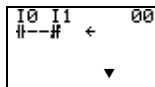

Press the **ALT** Button to switch to connection line write mode. The left arrow cursor will flash.

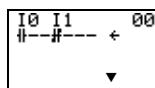

Press the **Right** Button to draw a connection line to the output.

Writing Outputs

Output Configuration

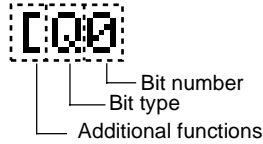

■ Memory Areas

Symbol	Name	Bit type and number
Q	CPU Unit output bits	Q0 to Q3 (4 outputs)
Y	Expansion I/O Unit output bits	Y0 to Yb (12 outputs) (See note 1.)
M	Work bits	M0 to Mf (16 bits)
H	Holding bits	H0 to Hf (16 bits)

Note Can be used only when Expansion I/O Units are connected.

■ Additional Functions for Output Bits

Symbol	Name
[Normal operation
S	Set operation
R	Reset operation
A	Alternate operation

Additional Functions for Bit Outputs

[: Normal output	S: Set	R: Reset	A: Alternate
I0 #-----[Q0	I1 #-----SQ1	I2 #-----RQ2	I3 #-----AQ3
Q0 turns ON and OFF when execution condition I0 turns ON and OFF.	Q1 turns ON and stays ON when execution condition I1 turns ON once.	Q2 is forced OFF when execution condition I2 turns ON.	Q3 alternates between On and OFF each time execution condition I3 turns ON.

Timers, Holding Timers, Counters, and Display Output Configurations

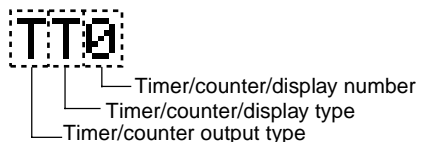

■ **Timers, Counters, and Display Bits**

Symbol	Name	Type and number	Output type
T	Timer	T0 to T7 (8 timers)	T: Trigger
#	Holding timer	#0 to #3 (4 timers)	R: Reset
C	Counter	C0 to C7 (8 counters)	C: Count D: Count direction R: Reset
D	Display bit	D0 to D7 (8 bits) (See note.)	D

Note For LCD-type CPU Units only.

3-3-3-3 Writing an Output to Q0

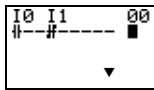

Press the **Right** Button again to draw a line to the output and move the highlighted cursor to the output write position.

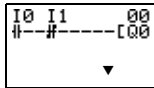

Press the **OK** Button to display the initial value for the output (normal output/Q0) and move the flashing cursor to the bit type Q position.

Use the **Up/Down** Buttons to select the bit type. Use the **Right/Left** Buttons to move the flashing cursor and use the **Up/Down** Buttons to select additional functions or select the bit address.

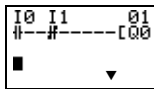

Press the **OK** Button twice to complete writing output Q0. The highlighted cursor will move to the input at the beginning of the next line.

3-3-3-4 Writing a Parallel Input for Q0

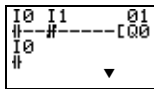

Press the **OK** Button to display input I0 and move the flashing cursor to the bit type I position.

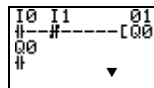

Press the **Up** Button to select **Q** (a CPU Unit output bit).

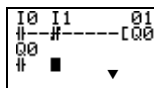
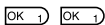

Press the **OK** Button twice to complete writing the parallel input for Q0. The highlighted cursor will move to the next input.

3-3-3-5 Drawing Connection Lines for OR Circuits

Drawing Connection Lines

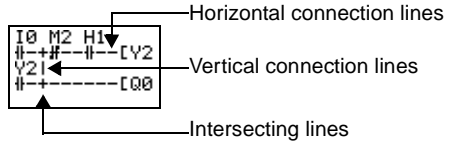

Press the **ALT** Button when the highlighted cursor is at the input write position to change the cursor to a left flashing arrow and enable connection lines to be drawn. Move the left arrow the position for drawing the connection line and press the **Up**, **Down**, **Left**, and **Right** Buttons to draw connection lines vertically and horizontally.

The connection line write mode will be left when the beginning or end of the line has been reached or if the OK and ESC Buttons are pressed.

Press the **ALT** Button to switch to connection line write mode.

ALT 7

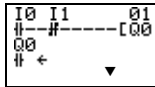

5

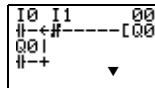

Press the **Up** Button to simultaneously draw a connection line both vertically and horizontally. The cross (+) indicates an intersection.

OK 1

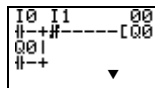

Press the **OK** Button to complete writing the connection line and change to a highlighted flashing cursor.

ESC 0

ESC 0

Press the **ESC** Button to complete the write operation.

Press the **ESC** Button again to return to the Menu Screen.

Note

1. Do not input a program where the connection lines double back on themselves. The program will not operate properly if such lines are drawn.
2. Always press the ESC Button and return to the Menu Screen after creating a program. If you do not press the ESC Button and return to the Menu Screen before

turning OFF the power, the program and settings will be deleted.

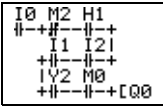

3-4 Confirming Ladder Program Operation

Always check the ladder program operation before using the ZEN.

- Note**
1. Before turning ON the power, check that the power supply, input circuits, and output circuits have been wired correctly.
 2. For systems with loads connected to the outputs that may cause serious injury or damage to equipment if operation is incorrect, remove the output wiring before performing trial operation.
 3. Always ensure safety in the vicinity before turning ON the power or switching operating modes.

Procedure for Checking Operation

Checks Before Turning ON the Power

1. Check that the ZEN is mounted and wired correctly.
2. Check that the operation of the ZEN will not have a negative impact on the system. Check for any dangers.
3. Turn ON the power supply to the ZEN.
Switch to RUN mode while the ZEN is stopped.

Operation Checks

4. Turn each input ON and OFF and check that the program is operating correctly.
5. Adjust any problems.

Method for Checking Operation

LCD-type CPU Units	Check the operation by the flashing input and output displays on the Main Screen.
LED-type CPU Units	Connect the ZEN Support Software and check operation using the monitor function. Refer to the operation manual for the ZEN Support Software.

Checking Operation

Changing Operating Mode

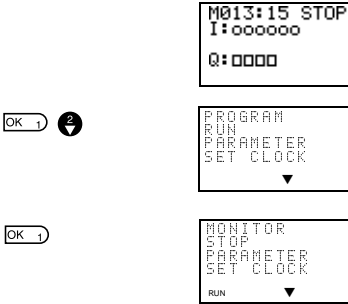

Press the **OK** Button to display the Menu Screen and press the **Down** Button to move the flashing cursor to RUN.

Press the **OK** Button to switch from STOP mode to RUN mode.

Checking Operations on Main Screen

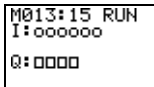

Press the **ESC** Button to switch to the Main Screen.

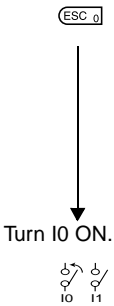

Turn I0 ON.

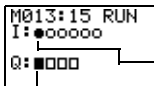

Q0 will turn ON when I0 turns ON. I0 ON. Q0 ON at the same time.

Turn I0 OFF.

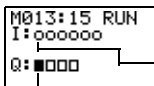

Q0 remains ON even if I0 turns OFF. I0 OFF. Q0 ON.

Turn I1 ON.

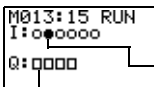

Q0 will turn OFF when I1 is turned ON. I1 ON. Q0 OFF.

Checking Operations Using Ladder Program Monitor



Select **Monitor** in RUN mode.

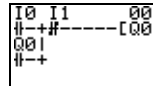

Press the **OK** Button to switch to the Ladder Program Monitoring Screen.

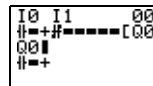

Q0 turns ON at the same time when I0 turns ON. When the bit is ON, the vertical and horizontal lines are thick.

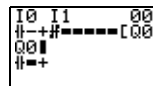

3-5 Correcting Ladder Programs

3-5-1 Changing Inputs

Move the highlighted cursor to the input to be changed.

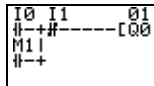
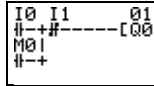
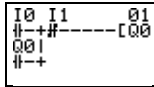

Press the **OK** Button to change the highlighted cursor to a flashing cursor and move the flashing cursor to the bit type position.

Use the **Up/Down** Buttons to select **M**.

Press the **Right** Button to move the flashing cursor to the bit address position. Use the **Up/Down** Buttons to change the bit address from 0 to 1.

Press the **OK** Button to complete the setting change.

3-5-2 Changing Additional Bit Output Functions

Move the highlighted cursor to the output to be changed.

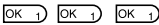
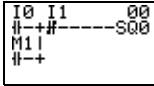
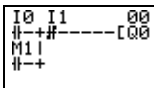
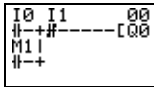

Change the additional function for the input for Q0 to S (Set).

Press the **OK** Button to change the highlighted cursor to a flashing cursor.

Press the **Left** Button to move the flashing cursor to the additional function position.

Press the **Up** Button twice to change the additional function from [to S.

Press the **OK** Button to complete the change.

3-5-3 Deleting Inputs, Outputs, and Connection Lines

Move the highlighted cursor to the position of the input, output, or connection line to be deleted and press the **DEL** Button.

Example: Deleting Serial Input M3

Move the highlighted cursor to the position of the input to be deleted.

```
I0 I1 M3 00
|--#--#--#--[Q1
Q0|X5
|--#-----[M0
```

DEL 6

```
I0 I1 00
|--#--#--#--[Q1
Q0|X5
|--#-----[M0
```

Press the **DEL** Button to delete the input and the related connecting lines at the same time.

Example: Deleting Vertical Connecting Lines

ALT 7

```
I0 I1 01
|--#-----[Q1
Q0|X5
|--←#-----[M0
```

Move the highlighted cursor to the input position to the right of the vertical line to be deleted. Press the **ALT** Button to switch to connection line write mode. The highlighted cursor will change to a left arrow cursor.

DEL 6

```
I0 I1 01
|--#-----[Q1
Q0|X5
|--←#-----[M0
```

Press the **DEL** Button to delete the vertical connection line.

3-5-4 Inserting Lines

- To insert a blank line, move the highlighted cursor to the beginning of the line where the blank line is to be inserted and press the **ALT** Button.

Move the highlighted cursor to the beginning of the next line (the line that will be after the inserted line.)

```
V2 I3 01
|--#-----[M2
T0 I2 Mf ←
|--#-----[M3
```

A circuit will be added here.

ALT 7

```
V2 I3 01
|--#-----[M2
Blank line █
T0 I2 Mf
|--#-----[M3
```

Press the **ALT** Button to insert one blank line.

- To add OR programming, inputs can be added between parallel inputs. Move the highlighted cursor to the beginning of the line where the input is to be inserted.

Move the highlighted cursor to the beginning of the next line (the line that will be after the inserted line.)

```
I0 I1 01
|--#-----[M0
M0| ←
|--#-----[M0
```

A input will be added here.

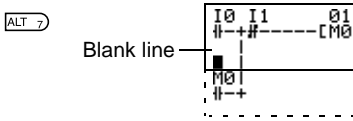

Press the **ALT** Button to reserve a 1-line space between the parallel inputs.

The vertical connection lines will be automatically extended.

Note A blank line cannot be inserted if an input or connection line is written in the last line (the 96th line).

3-5-5 Deleting Blank Lines

To delete a blank line, move the highlighted cursor to the beginning of the line to be deleted and press the **DEL** Button.

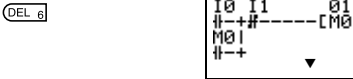
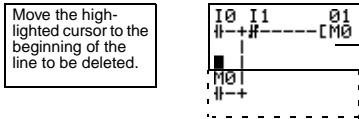

Press the **DEL** Button to delete one blank line. All following lines will move up one.

3-6 Using Timers (T) and Holding Timers (#)

The ZEN has 8 built-in timers and 4 built-in holding timers.

Timers	<p>The present value being timed will be reset when the timer switches from RUN mode to STOP mode or the power is turned OFF.</p> <p>There are four uses of the timer available, depending on the additional function selection.</p>
Holding timers	<p>The present value being timed is held even when the timer switches from RUN mode to STOP mode or the power is turned OFF. The time will continue when the trigger input turns ON again. The ON status of the timer bit is also held when the timer times out.</p> <p>Only ON-delay holding timers are supported.</p>

Timer Operation (T0 to T7)

Timer type		Operation		Main applications
X	ON delay timer	Turns ON after a set interval after the trigger input has turned ON.		Time lag operations
■	OFF delay timer	Stays ON while the trigger input is ON and turns OFF after a set interval after the trigger input has turned OFF.		Useful for timing for lighting and ventilating fans
O	One-shot pulse timer	Remains ON for a set interval when the trigger input turns ON.		Useful for quantitative operation where operation is always required for the same period.
F	Flashing pulse timer	Turns ON and OFF repeatedly at set intervals while the trigger input is ON.		Useful as an alarm circuit for flashing emergency lighting or buzzers.

Holding Timer Operation (#0 to #3)

Timer type		Operation		Main applications
X	ON delay timer only	Turns ON after a set interval after the trigger input has turned ON.		When operation is to be continued even during momentary power interruptions and longer power interruptions.

3-6-1 Settings in the Ladder Program Edit Screen

Timer triggers, reset outputs, and timer inputs are drawn on the Ladder Program Edit Screen. Settings are made on the Parameter Settings Screen.

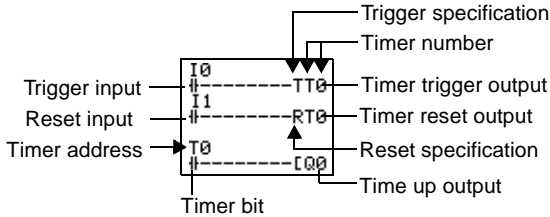

Timer address	Timers: T0 to T7 (8 timers)/ Holding Timers: #0 to #3 (4 timers)	
Trigger input	T (TRG)	Controls the timer trigger output. Triggers the timer when the trigger input turns ON.
Reset input	R (RES)	Controls the timer reset output. When the reset input turns ON, the present value is reset to 0 and the timer bit turns OFF. Trigger inputs are not accepted while the reset input is ON.
Timer bit	Turns ON according to the timer type.	

3-6-2 Settings in the Parameter Settings Screen

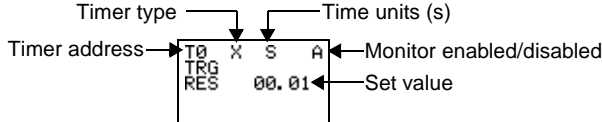

Timer Types

X	ON delay
■	OFF delay
O	One-shot pulse
F	Flashing pulse

Time Units and Settings

S	00.01 to 99.99 s (in 0.01-s units)	Error: 0 to -10 ms
M:S	00 min 01 s to 99 min 59 s (in minutes and seconds)	Error: 0 to -1 s
H:M	00 h 01 m to 99 h 59 m (in hours and minutes)	Error: 0 to -1 min

Monitor Enabled or Disabled

A	Operating parameters can be monitored and settings changed.
D	Operating parameters cannot be monitored nor settings changed.

3-6-3 Parameter Monitor Screen Display

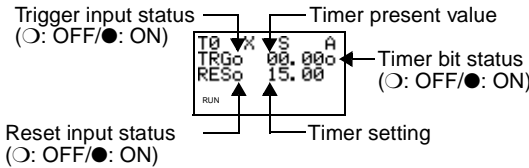

3-7 Using Counters (C)

Up to 8 counters can be used in incremental or decremental mode. The present value for counters and the status of counter bits (ON/OFF) are held even when the operating mode is changed or there is a power interruption.

Operation

Counter bits turn ON when the count value (present value) exceeds the setting (present value \geq set value). The count returns to 0 and the bits turns OFF when the reset input turns ON. Count inputs are not accepted while the reset input is ON.

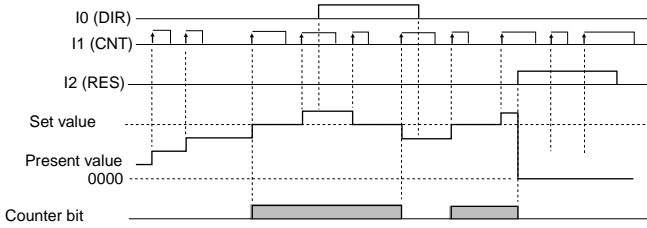

3-7-1 Settings in the Ladder Program Edit Screen

Outputs for the counter input, counter direction, and counter reset are written in the Ladder Program Edit Screen. Counter input conditions can also be written. Settings are made in the Parameter Settings Screen.

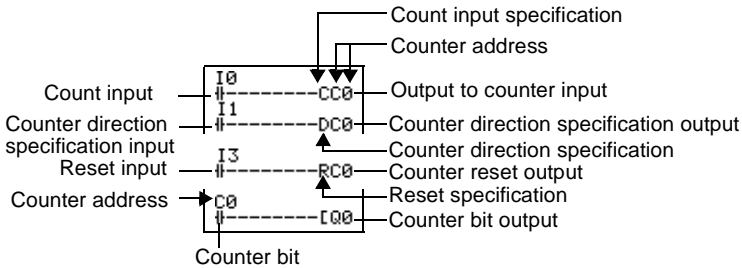

Counter address	C0 to C7 (8 points)	
Counter input	C (CNT)	Increments (or decrements) each time the count input turns ON.
Counter direction specification input	D (DIR)	Switches between incremental and decremental counting. OFF: Incremental ON: Decremental
Reset input	R (RES)	When the reset input turns ON, the present value returns to 0 and the counter bit turns OFF. Count inputs are not accepted while the reset input is ON.
Count input		Turns ON when the counter has counted out (PV ≥ SV)

3-7-2 Settings in the Parameter Settings Screen

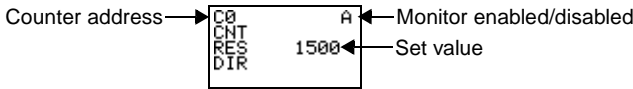

Set value	0001 to 9999 (4 decimal digits) times	
Monitor enabled/ disabled	A	Operating parameters can be monitored and settings changed.
	D	Operating parameters cannot be monitored or settings changed.

3-7-3 Parameter Monitor Screen Display

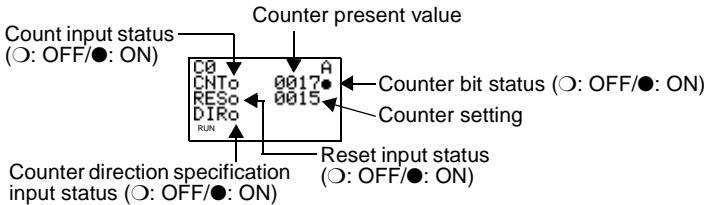

- Note**
- To reset the counter present value and counter bit status (ON/OFF) when at power interruptions or when the operating mode is changed, create a counter reset circuit when you first execute the program. An example is shown below.

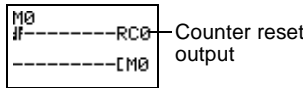

- If the counter input and counter direction are input simultaneously, place the output for the counter direction before the output for the counter input in the program.

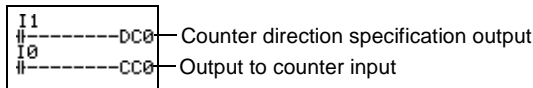

3-8 Using Weekly Timers (@)

Weekly timers turn ON between the specified start and stop times on the specified days. Weekly timers have 8 points (@0 to @7.)

Operation

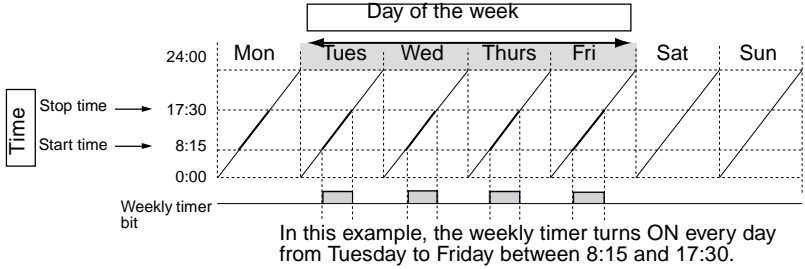

3-8-1 Settings in the Ladder Program Edit Screen

Weekly timer inputs are written in the Ladder Program Edit Screen. Settings are made in the Parameter Settings Screen.

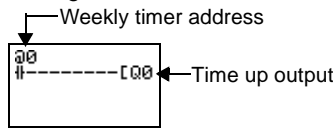

Weekly timer addresses	@0 to @7 (8 timers)
------------------------	---------------------

3-8-2 Settings in the Parameter Settings Screen

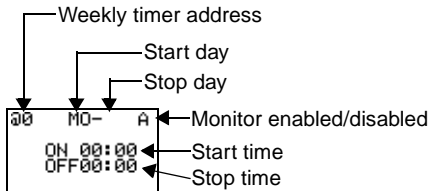

Note When the flashing cursor is on the start day, press the **Right** Button and then the **Up/Down** Buttons to set the stop day. If the stop day is not set, the timer will operate according to the set time only.

Day	Start day	Sun/Mon/Tues/Wed/Thurs/Fri/Sat
	Stop day	Sun/Mon/Tues/Wed/Thurs/Fri/Sat/None
Time	Start time	00:00 to 23:59
	Stop time	00:00 to 23:59
Monitor enabled/disabled	A	Operating parameters can be monitored and settings changed.
	D	Operating parameters cannot be monitored or settings changed.

Relationship between Start and Stop Days and Times

Setting and operation		Setting example	Operation
Start and stop day	When start day is before stop day	MO - FR	Operates Monday to Friday every week.
	When start day is after stop day	FR - MO	Operates every Friday through to the following Monday.
	When start and stop days are the same	SU - SU	Operates regardless of the day of the week.
	When stop day not set	SU -	Operates every Sunday only.
Start and stop time	When start time is before stop time	ON: 08:00 OFF: 17:00	Operates 8:00 to 17:00 every day.
	When start time is after stop time	ON: 21:00 OFF: 06:00	Operates 21:00 to 0:60 the next day.
	When start and stop times are the same	ON: 13:00 OFF: 13:00	Operates regardless of the time.

3-8-3 Parameter Monitor Screen Display

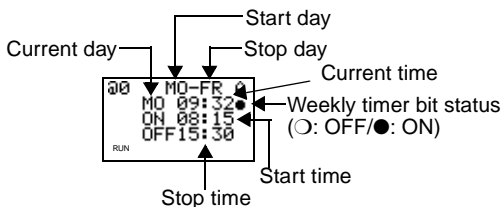

3-9 Using Calendar Timers (*)

Calendar timers turn ON between specified dates. There are 8 calendar timers (*0 to *7).

Operation

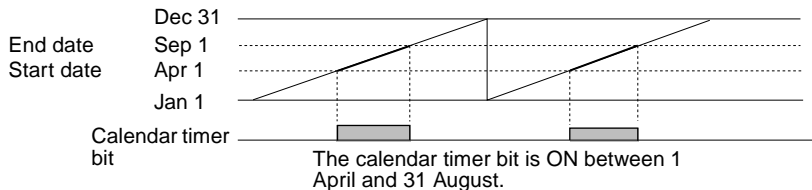

3-9-1 Settings in the Ladder Program Edit Screen

Calendar timer inputs are written in the Ladder Program Edit Screen. Settings are made in the Parameter Settings Screen.

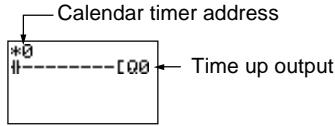

Calendar timer address	*0 to *7 (8 timers)
------------------------	---------------------

3-9-2 Settings in the Parameter Settings Screen

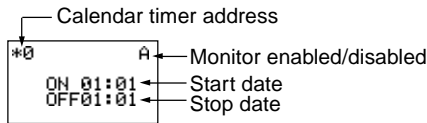

Start date	Jan 1 to Dec 31	
Stop date (See note.)	Jan 1 to Dec 31	
Monitor enabled/ disabled	A	Operating parameters can be monitored and settings changed.
	D	Operating parameters cannot be monitored or settings changed.

Relationship between Start and Stop Dates

Setting and operation		Setting example	Operation
Start and stop date settings and operation	When start date is before stop date	ON: 04/01 OFF: 09/01	Operates between 1 April and 31 August. (See note.)
	When start date is after stop date	ON: 12/26 OFF: 01/07	Operates between 26 December and 6 January the following year.
	When start and stop dates are the same.	ON: 07/26 OFF: 07/26	Operates regardless of the date.

Note To stop operation on August 31, set the stop date to the following day (September 1).

3-9-3 Parameter Monitor Screen Display

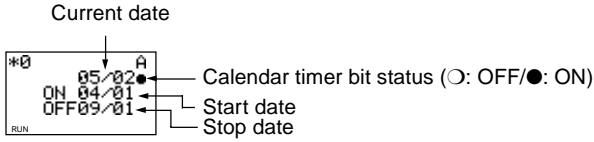

3-10 Analog Inputs (Analog Comparators (A))

Analog voltage inputs between 0 and 10 V can be incorporated into the CPU Units with a DC power supply (2 points, I4 and I5).

The analog input signal is converted to BCD (00.0 to 10.0). The results can be used with one of the comparators A0 to A3, and the 4 comparison outputs can be used as input conditions in the program.

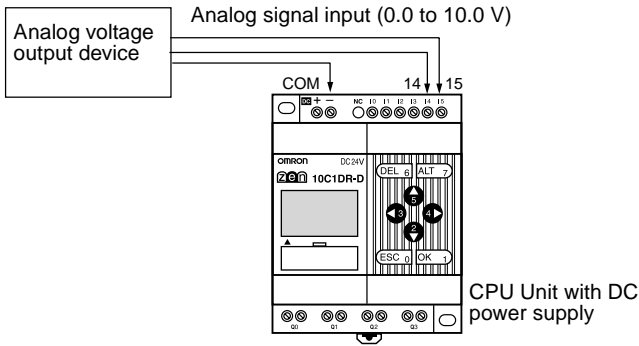

Operation

- Example 1
(When comparison shows analog input 1 (I4) \geq 5.2 V)

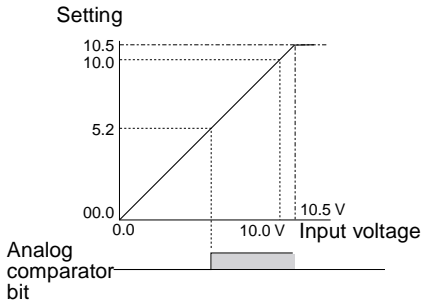

The analog comparator bit turns ON when the analog input voltage reaches is 5.2 V or higher.

- Example 2
(When comparison shows analog input 1 (IN4) is \leq analog input 2 (I5))

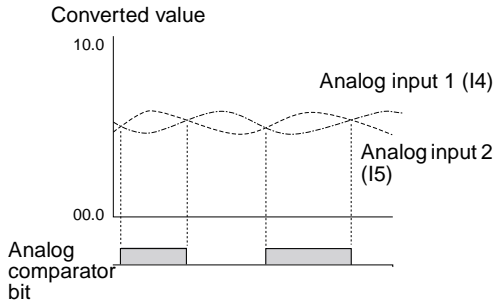

The analog comparator bit turns ON when the analog input 2 voltage is higher than the analog input 1 voltage.

Note Do not make negative signal inputs to analog inputs I4 or I5. If negative signals are made, the internal elements may be damaged.

3-10-1 Settings in the Ladder Program Edit Screen

The analog comparator input is written in the Ladder Program Edit Screen. Settings are made in the Parameter Settings Screen.

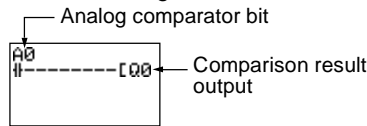

Analog comparator address	A0 to A3 (4 comparators)
---------------------------	--------------------------

3-10-2 Settings in the Parameter Settings Screen

- Comparing Analog Inputs and Constants
(When $I4 \geq \text{constant}$)

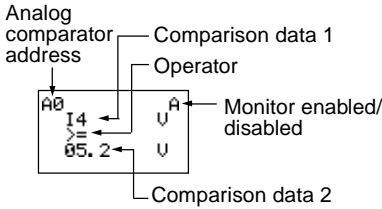

- Comparing Analog Inputs
(When $I4 \leq I5$)

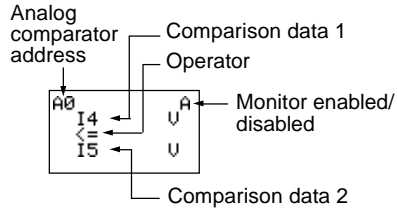

Analog comparator address	A0 to A3 (4 comparators)	
Comparison data	1	I4: Analog input 1 (I4) I5: Analog input 2 (I5) * Size comparison between I4 and I5. * Size comparison between I4 and constant.
	2	I5: Analog input 2 (I5) Constant: 00.0 to 10.5 * Size comparison between I5 and constant.
Operator	>=: Analog comparator bit turns ON when comparison data 1 \geq comparison data 2.	
	<=: Analog comparator bit turns ON when comparison data 1 \leq comparison data 2.	
Monitor enabled/disabled	A	Operating parameters can be monitored and settings changed.
	D	Operating parameters cannot be monitored or settings changed.

3-10-3 Parameter Monitor Screen Display

- Comparing Analog Inputs and Constants
(When $I4 \geq \text{constant}$)

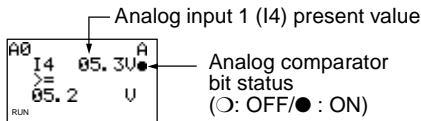

- Comparing Analog Inputs
(When $I4 \leq I5$)

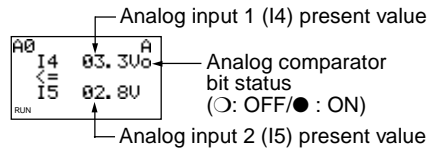

3-11 Comparing Timer/Counter Present Values Using Comparators (P)

Timer (T), holding timer (#), and counter (C) present values can be compared. The present values of the same type of timer or counter can be compared, or they can be compared to constants.

Operation

- Example 1
(When comparison setting is holding timer #0 \geq 12 min 34 s)

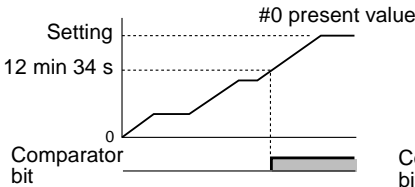

- Example 2
(When comparison setting is counter 1 (C1) \leq counter 2 (C2))

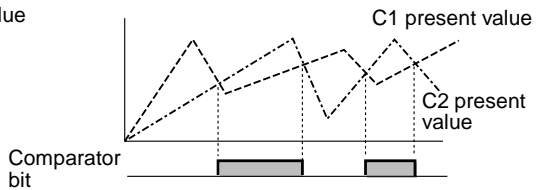

3-11-1 Settings in the Ladder Program Edit Screen

Comparator inputs are written in the Ladder Program Edit Screen. Settings are made in the Parameter Settings Screen.

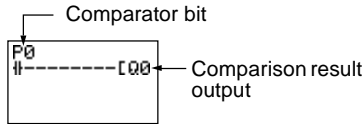

Comparator addresses	P0 to P5 (16 points)
----------------------	----------------------

3-11-2 Settings in the Parameter Settings Screen

- Comparing Holding Timers and Constants
(When Holding Timer #0 \geq 12 min 34 s)

- Comparing Counters
(When counter 1 (C1) \leq counter 2 (C2))

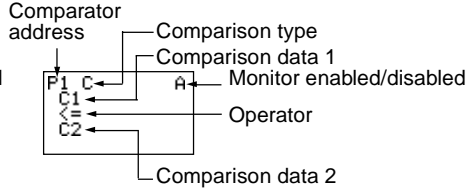
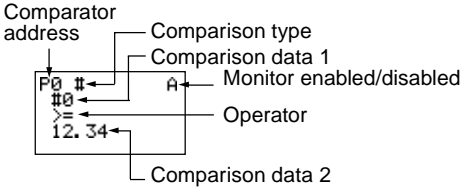

Comparison type		T: Timer #: Holding timer C: Counter	
Comparison data	1	T: T0 to T 7 Timers 0 to 7 #: #0 to #3 Holding timers 0 to 3 C: C0 to C7 Counters 0 to 7	* Size comparison between T and T or T and constant. * Size comparison between # and # or # and constant.
	2	T: T0 to T 7 Timers 0 to 7 #: #0 to #3 Holding timers 0 to 3 C: C0 to C7 Counters 0 to 7 Constant: 00.00 to 99.99 when comparison type is T/# 0000 to 9999 when comparison type is C	* Size comparison between C and C or C and constant.
Operator		\geq : Timer/counter comparator bit turns ON when comparison data 1 \geq comparison data 2.	
		\leq : Timer/counter comparator bit turns ON when comparison data 1 \leq comparison data 2.	
Monitor enabled/ disabled	A	Operating parameters can be monitored and settings changed.	
	D	Operating parameters cannot be monitored or settings changed.	

3-11-3 Parameter Monitor Screen Display

- Comparing Holding Timers and Constants
(When Holding Timer #0 \geq 12 min 34 s)
- Comparing Counters
(When counter 1 (C1) \leq counter 2 (C2))

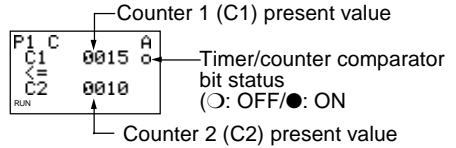
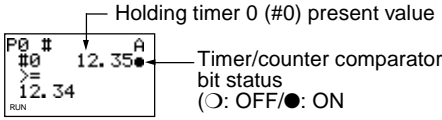

- Note**
1. Press the **ALT** Button to switch between comparison data 2 timer/counter address and constants.
 2. The time unit is determined as follows when timers or holding timers have been specified under comparison type:
 - a) When a constant has been set to as comparison data 2, the time unit is automatically aligned with the unit for comparison data 1 timers or holding timers.
 - b) The time units are automatically aligned when the units are different for comparison data 1 and 2 timers.

3-12 Displaying Messages (Display Bits (D))

A user-set message, the time, a timer/counter present value, or an analog conversion value can be displayed on the LCD screen. If multiple displays are used, multiple data can be displayed on the same screen.

- Operation Example 1

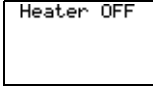

Monitors the system operation status.

Settings Details

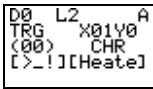

- Operation Example 2

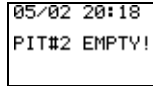

Displays the date and time that the system error occurred.

Settings Details

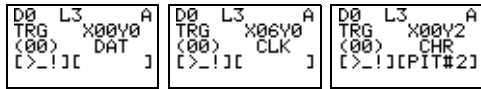

3-12-1 Settings in the Ladder Program Edit Screen

The display is written in the Ladder Program Edit Screen. Settings are made in the Parameter Settings Screen.

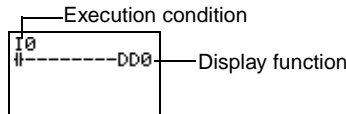

Display address	D0 to D7 (8 points)
-----------------	---------------------

3-12-2 Settings in the Parameter Settings Screen

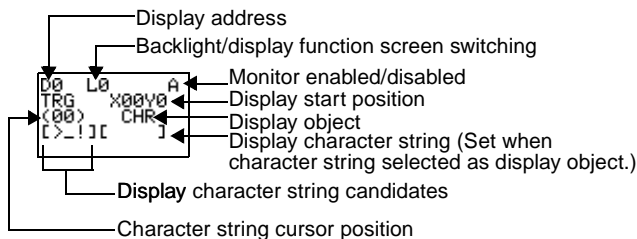

Backlight/display function screen switching	L0	No backlight; No switching to display function screen (See note 1.)
	L1	Backlight; No switching to display function screen (See note 1.)
	L2	No backlight; Switching to display function screen (See note 2.)
	L3	Backlight; Switching to display function screen (See note 2.)
Display start position	X (digit):	00 to 11
	Y (line):	0 to 3
Display object	CHR	Characters (12 max.: Alphanumeric characters and symbols)
	DAT	Month/day (5 digits: □□/□□)
	CLK	Hour/minutes (5 digits: □□:□□)
	I4 to I5	Analog conversion (4digits: □□.□)
	T0 to T7	Timer present value (5 digits: □□.□□)
	#0 to #3	Holding timer present value (5 digits: □□.□□)
	C0 to C7	Counter present value (4 digits: □□□□)
	Monitor enabled/disabled	A
D		Operating parameters cannot be monitored.

- Note**
- When L0 or L1 are selected to disable the display function screen, the display function screen will not be displayed automatically. Use operation buttons to move to the display function screen.
 - When L2 or L3 are selected (switching to display function screen), the ZEN switches to the display function screen if the display function is enabled and the specified data is displayed. The Main Screen will no longer be displayed. To display the Main Screen, change the CPU Unit to STOP mode.

Settings when Character (CHR) Selected

Move the highlighted cursor to the display character string column.

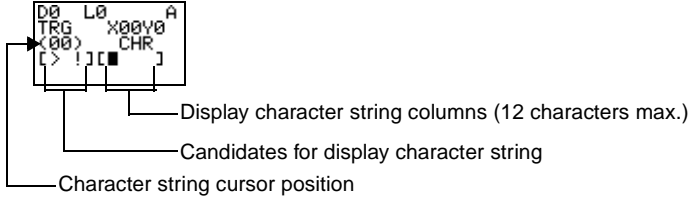

OK →

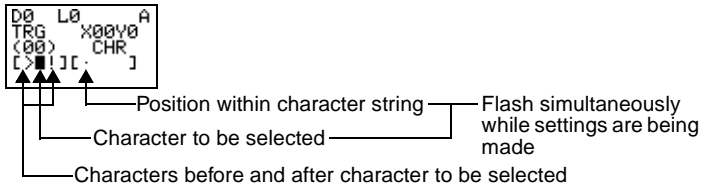

Use the **Up/Down** Buttons to scroll through the candidate characters.

Alternates display of the candidate character and the position mark. Candidate is highlighted and flashing.

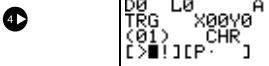

Use the **Right** Button to move the character string position to the right. Use the **Left** Button to move the character string to the left.



OK →

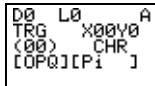

3-13 Using Button Switches (B)

For LCD-type CPU Units, the operation buttons are used to perform operations for input bits. They are useful when checking program operations or forcefully resetting holding timers or counters.

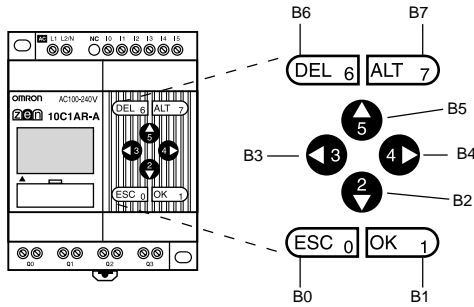

Button switch address	Operation button
B0	ESC
B1	OK
B2	Down
B3	Left
B4	Right
B5	Up
B6	DEL
B7	ALT

Using Button Switches

- The buttons can also be used as “hidden keys” for software resets of counters or holding bit present values.

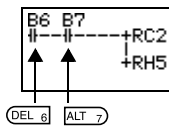

Press the **DEL+ALT** Buttons simultaneously during operation to reset the counter C2 present value to 0 and the holding bit H5 to OFF.

Note

- The buttons can be used as operation buttons for each screen. When using the buttons as buttons switches, make your selections based on the screen status.
- The operation buttons can be used for ZEN operations, such as menu selections, regardless of whether or not button switches (B) are being used. When a button is pressed for ZEN operations, the button switch (B) also turns ON. Make sure that the system will not

be affected by this before pressing buttons.

SECTION 4

Special Functions

This section describes how to protect ladder programs, stabilize inputs, make LCD screen adjustments, and make summer time settings.

4-1	Protecting Programs	72
4-1-1	Setting a Password	73
4-1-2	Deleting Registered Passwords	73
4-2	Stabilizing Input Operations	74
4-3	Changing Backlight Automatic Cutout Time	76
4-4	Adjusting LCD Screen Contrast	77
4-5	Setting Summertime	77
4-6	Reading System Information	78

4-1 Protecting Programs

The ZEN has a password function to prevent incorrect manipulation of ladder programs or settings data by other operators.

Note Always record your password for future reference when using the password function. You will no longer be able to operate the ZEN if you forget your password.

- The password setting range is 0000 to 9999 (4 decimal digits).
- You will no longer be able to perform the following operations if the password is not input correctly.

Edit ladder programs

Monitor ladder programs

Change or delete the password

Set the input filter

Set the node address

- When any of these functions is selected from the menu, the Password Input Screen will be displayed. If the password is input correctly, the display will move to the next screen for the selected function. However, if the password is input incorrectly, the next screen will not be displayed.

4-1-1 Setting a Password

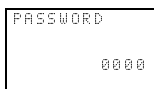
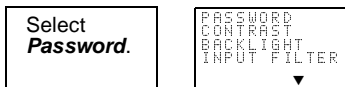
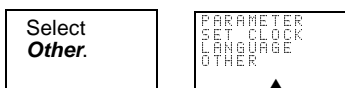

Press the **OK** Button to change to a flashing cursor and enable a password to be set.



Set the password.

Use the **Left** and **Right** Buttons to move to the digit to be changed.

Use the **Up/Down** Buttons to input a numeral between 0 and 9.

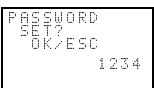

Press the **OK** Button. A confirmation message will be displayed.



The -mark will appear at the bottom right of the screen when a password has been registered.

Note The display will automatically change to the Waiting for Password Input Screen when making settings that require a password to be input. Use the same method as outlined above to input the registered password.

4-1-2 Deleting Registered Passwords

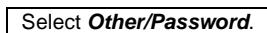

Press the **OK** Button to change to a flashing cursor and to enable password setting.

Input the registered password.



Use the **Left** and **Right** Buttons to move to the digit to be changed.

Use the **Up/Down** Buttons to input a numeral between 0 and 9.

OK ↵

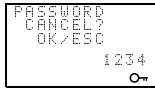

Press the **OK** Button to display a message asking whether or not to delete the set password.

If the input password does not match the registered password, the display will return to the original screen.

If the password was correct, press the **OK** Button to delete the password.

OK ↵

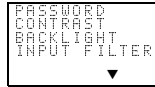

← The $\circ\rightarrow$ mark will disappear when the password is deleted.

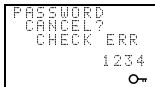

If the input password does not match the registered password, a CHECK ERR message will be displayed. Re-enter the password correctly.

4-2 Stabilizing Input Operations

If external input contacts chatter, ZEN operation may become unstable. Set an input filter to stabilize operation. Input filters can be set separately for the CPU Unit and each Expansion I/O Unit.

Operation (Example: DC Input Circuits)

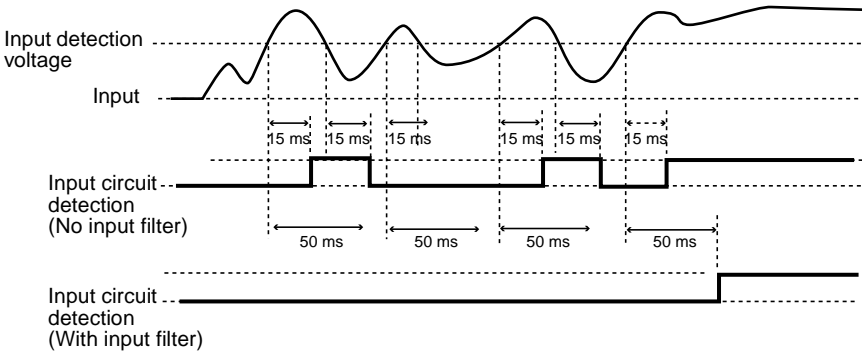

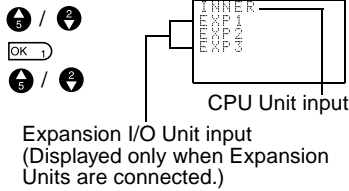
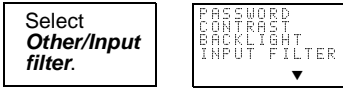

Press the **OK** Button to display the Input Filter Settings Menu.

Use the **Up** and **Down** Buttons to select from the menu the Unit for which the input filter is to be set.

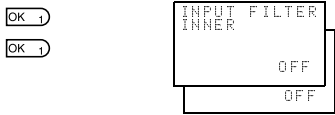

Press the **OK** Button twice to change to a flashing cursor and enable input filter settings to be made.

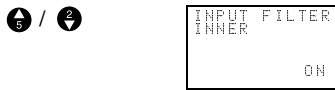

Use the **Up/Down** Buttons to switch between ON and OFF.



Press the **OK** Button to confirm the setting.
Press the **OK** Button again to complete the setting.

Note



1. The filter timers outlined in the following table are set for each input type when the input filter function is set.

Input specifications		Input filter not used	Input filter used
AC input	100 VAC	50 ms	70 ms
	240 VAC	100 ms	120 ms
DC input		15 ms	50 ms

2. The input filter settings are read when the ZEN starts operation.

4-3 Changing Backlight Automatic Cutout Time

The LCD backlight automatically turns ON when button operations are performed. It then turns OFF automatically 2 minutes after button operations stop. The default backlight cutout setting of 2 minutes can be changed to 10 or 30 minutes or the backlight can be set to remain ON continuously.

Button operation	Operation starts	Operation stops	
Display function (when L1 or L3 is set)	OFF → ON — — DDO	ON → OFF — — DDO	Cutout time ←————→
Backlight status	Lit.	Remains lit.		Remains lit.
				

Select
**Other/
Backlight.**

```
PASSWORD
CONTRAST
BACKLIGHT
INPUT FILTER
▼
```

OK →

```
BACKLIGHT
2 min
```

Press the **OK** Button to display the current backlight cutout setting.

OK →

Press the **OK** Button again to change to a flashing cursor and enable backlight cutout time settings to be made.

5 / 2

```
BACKLIGHT
10 min
```

Use the **Up** and **Down** Buttons to set the cutout time.

- 2 ON (Continuously ON)
- ↓ 30 min
- ↑ 10 min
- 5 2 min

OK →

Press the **OK** Button to confirm the setting.

OK →

Press the **OK** Button again to complete the setting.

Note The backlight cutout time is used not only to determine if and when the backlight turns OFF after button operations have stopped. If backlight has been specified to turn ON with the display function, the same setting is used to determine if and when the backlight turns OFF once the execution of the display function has been completed.

4-4 Adjusting LCD Screen Contrast

Use the following procedure to adjust the contrast of the LCD (liquid crystal display) screen if the screen is too dark or too light and difficult to read.

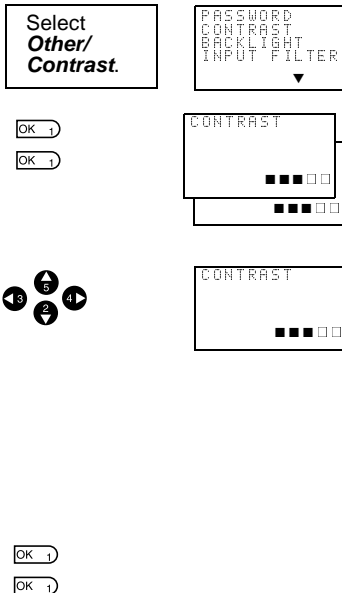

Press the **OK** Button to display the current setting in a 5-level bar graph.

Press the **OK** Button again to change to a flashing cursor and enable the contrast to be adjusted.

Use the **Up/Down** and **Left/Right** Buttons to adjust the contrast.

▲ / ◀ Increase the contrast.
▼ / ▶ Decrease the contrast.

Lighter ■ □ □ □ □
 ↑ to Four setting levels
 are available.
 ↓
 Darker ■ ■ ■ ■ ■

Press the **OK** Button to confirm the setting.

Press the **OK** Button again to complete the setting.

4-5 Setting Summertime

Set the Summertime function when using the ZEN in countries that use Summertime.

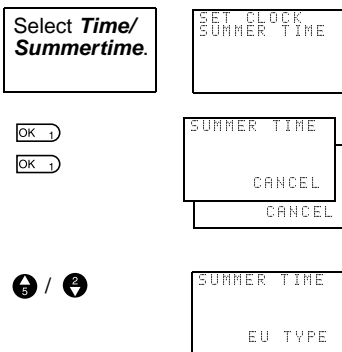

Press the **OK** Button to display the current settings.

Press the **OK** Button again to change to a flashing cursor and enable Summertime settings to be made.

Use the **Up** and **Down** Buttons to make the setting.

- 2 US Type (for Summertime in American countries)
- ↓ EU Type (for Summertime in European countries)
- ↑ Manual (for manual settings)
- 5 Cancel (for no Summertime)



Press the **OK** Button to confirm the setting.
Press the **OK** Button again to complete the setting.

Cancel	Summertime settings are not made. Any Summertime settings that have been made will be deleted.	
Manual	Moves the clock forward 1 hour.	
EU Type	Summertime period: 2:00 a.m last Sunday in March to 2:00 a.m. last Sunday in August	Once the start time (2:00 a.m.) has been reached, the clock is moved forward 1 hour to 3:00 a.m. When the stop time (2:00 a.m.) has been reached, the clock is moved backwards 1 hour to 1:00 a.m.
US Type	Summertime period: 2:00 a.m first Sunday in April to 2:00 a.m. last Sunday in August	

Note When Summertime has been set, an "S" will appear at the top right of the Time Settings Screen during the Summertime period.



"S" displayed during the Summertime period.

4-6 Reading System Information

The software version of the CPU Unit, the number of CPU Unit and Expansion I/O Unit I/O points, and other information can be read.

Select **Other/ System information.**

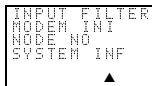

U	Ver 1.00	Software version (e.g., Ver 1.00)
D	2001 APR 1	Date software created (e.g., 2001 April 1)
C	6/4	No. of CPU Unit I/O points (e.g., 6 inputs, 4 outputs)
E	4/0	No. of Expansion Unit 1 I/O points (e.g., 4 inputs, 0 outputs)
E	4/0	No. of Expansion Unit 2 I/O points (e.g., 4 inputs, 0 outputs)
E	0/4	No. of Expansion Unit 3 I/O points (e.g., 0 inputs, 4 outputs)
F	0	(For function expansion)
L	0	LCD screen selection (e.g., Yes)
C	0	Calendar and time function selection (e.g., Yes)
A	0	Analog input selection (e.g., No)

SECTION 5

Optional Products

This section describes how to mount Battery Units, use Memory Cassettes, and how to connect the ZEN Support Software.

5-1	Mounting Battery Units	80
5-2	Using Memory Cassettes	81
5-3	Connecting the ZEN Support Software	83

5-1 Mounting Battery Units

Ladder programs and all settings are saved to the CPU Unit EEPROM but calendar, clock, and holding timer bits and holding timer/counter present values are held by the capacitor. Therefore, if the power supply is interrupted for an extended time (2 days or more at 25°C), that data is reset. Mount a Battery Set (optional) for systems where the power supply may be interrupted for long periods.

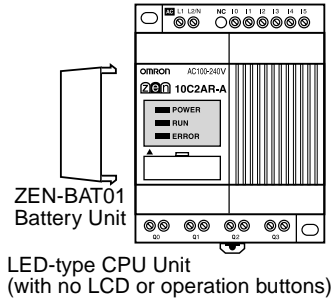
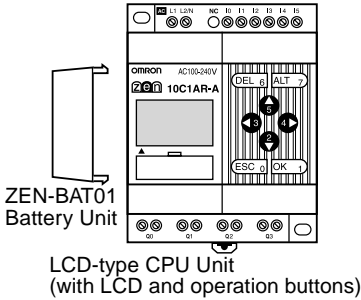

Mounting Method

- 1,2,3...**
1. Tilt the Battery Unit to the side and insert the claw at the bottom of the Battery Unit into the mounting hole on the left side of the CPU Unit.

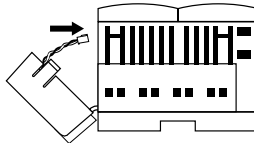

2. Connect the Battery Unit cord to the CPU Unit connector.

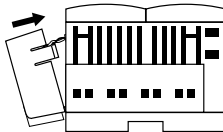

3. Push the claw at the top of the Battery Unit into the CPU Unit.

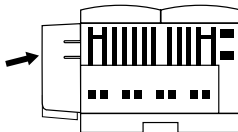

- Note**
1. Turn OFF the power supply to the CPU Unit before mounting the Battery Unit.
 2. Do not short the positive and negative terminals or recharge, dismantle, overheat, or incinerate the Battery Unit.
 3. Do not drop the Battery Unit. The battery may leak or other damage occur if the Battery Unit is dropped.
 4. The Battery Unit has a life of 10 years min.

5-2 Using Memory Cassettes

Optional Memory Cassettes can be used to save the ladder program and settings and to copy programs and settings to other CPU Units.

Mounting Memory Cassettes

- 1,2,3...**
1. Remove the connector cover on the front of the ZEN.

LCD-type CPU UNIT
(with LCD and operation buttons)

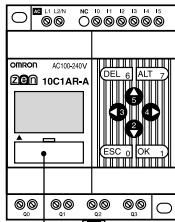

LED-type CPU Unit
(no LCD/operation buttons)

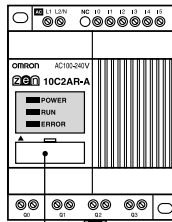

Connector cover

(Use a flat-blade screwdriver if the cover is difficult to remove.)

2. Mount the Memory Cassette.

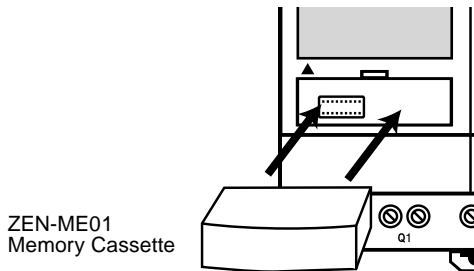

- Note** Always turn OFF the power supply to the CPU Unit before removing or mounting Memory Cassettes.

Transferring Programs

Select **Program** in STOP mode.



OK



Select **Memory Cassette**.

OK



The Operation Menu for Memory Cassettes will be displayed.

Use the **Up/Down** Buttons to move the flashing cursor and press the **OK** Button to select an operation.

Menu	Operation
Save	Saves CPU Unit programs to the Memory Cassette. Existing program on the Memory Cassette will be overwritten.
Load	Transfers programs from the Memory Cassette to the CPU Unit. Existing programs on the CPU Unit will be overwritten.
Erase	Deletes Memory Cassette programs.

Note

1. The transferable program includes the ladder programs, parameters, and all settings data. The present values for the timers, holding timers, counters, and holding bits cannot be transferred.
2. Only error-free programs can be transferred. The program will not be transferred if there is any illegal data in the program.
3. The Memory Cassette can be written to up to 100,000 times.

Mounting Memory Cassettes to LED-type CPU Units

When a Memory Cassette with an error-free program is mounted to an LED-type CPU Unit, the program on the Memory Cassette is automatically transferred to the CPU Unit. An existing program in the CPU Unit will be overwritten.

5-3 Connecting the ZEN Support Software

The ZEN Support Software can be used for programming and monitoring. Refer to the *ZEN-SOFT01 ZEN Support Software Operation Manual (W386)* for information on the functions and operation of the ZEN Support Software.

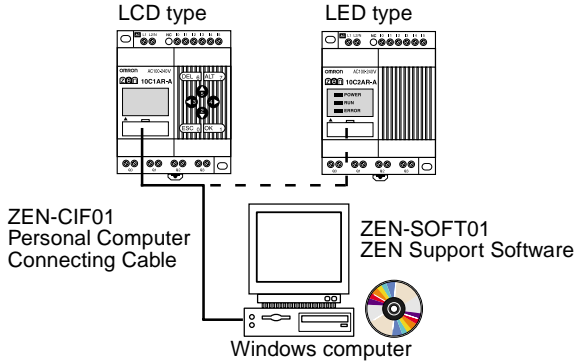

Computer Specifications

Item	Conditions
Operating system	Windows 95, 98, ME, 2000, NT4.0 Service Pack 3
CPU	Pentium 133 MHz or greater (Pentium 200 MHz or greater recommended)
Memory	64 Mbytes min.
HD capacity	40 Mbytes free disk space min.
CD-ROM drive	Required.
Communications	1 serial (COM) port
Keyboard and mouse	Required
Monitor	800 x 600 dots (SVGA) min.; 256 colors min.

Setting Node Addresses

When a ZEN Support Software is connected, the node address set on the ZEN Support Software must match the node address set on the CPU Unit. Communications cannot be performed if the node addresses do not match. Use the following procedure to set the node addresses.

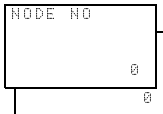
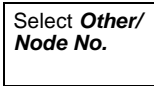

Press the **OK** Button to display the current settings.

Press the **OK** Button again to enable the node address to be set.

Use the **Up/Down** and **Right/Left** Buttons to set the node address between 0 and 9.

Press the **OK** Button to confirm the setting.

Press the **OK** Button again to complete the setting.



SECTION 6

Troubleshooting

This section lists the error messages and provides probable causes and countermeasures for troubleshooting.

6-1	Troubleshooting	86
6-2	Error Messages	86
6-3	Deleting Error Messages	88

6-1 Troubleshooting

Search for the cause of the error and take immediate countermeasures if ERR or any other error message appears on the LCD screen (for LCD-type CPU Units) or the ERROR indicator is lit (on LED-type CPU Units).

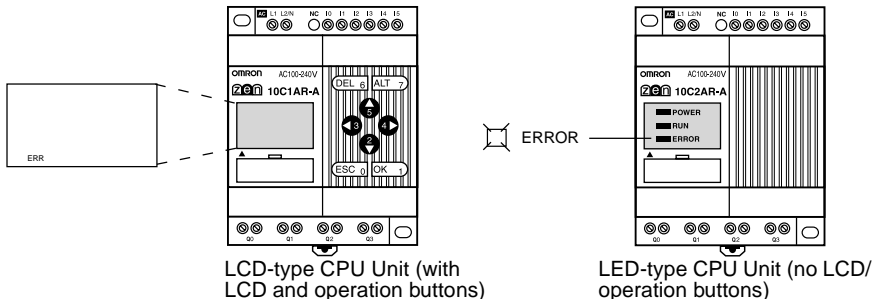

6-2 Error Messages

The following tables list the error messages that are displayed when an error occurs.

Power ON but No Operation

Error message	Probable cause	Possible solution
MEMORY ERR	Program error.	The ladder program and parameter settings have been cleared. Write a program to the ZEN again.
I/O BUS ERR	Expansion I/O Unit connection error.	Turn OFF the power supply and check that the Expansion I/O Units are connected properly.
UNIT OVER	More than 3 Expansion I/O Units connected.	Turn OFF the power supply and reduce the number of Expansion I/O Units to 3 or less.
I/O VRFY ERR	Bit type that cannot be used with system configuration included in ladder program. (See note.)	Remove the illegal bit type from the program.

Note I/O Verification Error

Expansion I/O Unit I/O bits (X/Y): Bit not allocated in system configuration has been used.

Analog comparators (A): Used with AC power supply type.

Weekly timers (@)/Calendar timers (*): Used with ZEN without calendar/clock function.

Display function (D):

- For AC power supply types, analog-converted values (I4/I5) are specified as the displayed items.
- For types without calendar/clock function, the date (DAT) and time (CLK) are specified as the displayed items.

Error at Power ON or During Operation

Error message	Probable cause	Possible solution
I/O BUS ERR	Expansion I/O Unit connection error.	Turn OFF the power supply and check that the Expansion I/O Unit is connected properly.
MEMORY ERR	Program error.	Execute the All Clear operation and then re-write the program.
I2C ERR	Communications error between Memory and RTC.	Press any operation button and clear the error. Replace the CPU Unit if the error occurs frequently.

Error During Program Transfer from Memory Cassette

Error message	Probable cause	Possible solution
M/C ERR	Memory cassette program error.	Save the error-free program to the Memory Cassette again.

Note Use the ZEN Support Software to read error messages for LED-type CPU Units.

6-3 Deleting Error Messages

A flashing error message is displayed when an error occurs. Turn OFF the power supply and remove the cause of the error.

Press any operation button to delete the error message. Once the error has been removed the display will return to normal.

Error Message
Display
Screen

```
I/O BUS ERR
```

Press either the **ESC**, **OK**, **DEL**, **ALT**, **Left/Right**, or **Up/Down** Buttons. Any button can be pressed to delete the error message.

```
M013:15 STOP  
I:000000  
Q:0000
```

Press any button to return to normal display.

Note The error display will remain for internal errors that cannot be fixed, such as I/O Bus errors and I/O Unit Over errors.



```
M013:15 STOP  
I:000000  
Q:0000  
ERR
```

↑ ERR will remain on the display.

Appendix A

Product Configurations



CPU Units

Shape	Power supply	Inputs		Outputs		Calendar and clock function	Model number
LCD type With LCD and operation buttons 	100 to 240 VAC, 50/60 Hz	100 to 240 VAC	6 inputs	Relays	4 outputs	Yes	ZEN-10C1AR-A
	(Not isolated)						ZEN-10C1DR-D
	24 VDC	24 VDC					
LED type No LCD nor operation buttons 	100 to 240 VAC, 50/60 Hz	100 to 240 VAC				No	ZEN-10C2AR-A
	(Not isolated)				ZEN-10C2DR-D		
	24 VDC	24 VDC					

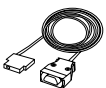

Programming Device

Name and appearance	Functions	Model number
ZEN Support Software 	Runs on Windows 95, 98, ME, 2000, or NT4.0 Service Pack 3 (CD-ROM) Used for offline programming, all parameter settings, program transfers, and printing.	ZEN-SOFT01
Personal Computer Connecting Cable 	Connects the computer and ZEN when the ZEN Support Software is used.	ZEN-CIF01

Expansion I/O Units

No. of I/O points	Inputs		Outputs		Model number
8 I/O 	100 to 240 VAC (isolated)	4 inputs	Relays	4 out-puts	ZEN-8EAR
	24 VDC (isolated)				ZEN-8EDR
4 inputs 	100 to 240 VAC (isolated)	---	---	---	ZEN-4EA
	24 VDC (isolated)				ZEN-4ED
4 outputs 	---	---	Relays	4 out-puts	ZEN-4ER

Optional Products

Name and appearance	Functions	Model number
Memory Cassette 	EEP-ROM Used to save and copy programs.	ZEN-ME01
Battery Unit 	Uses a battery to back up programs and data. Mount a Battery Unit if the loss of calendar, clock, holding bit, holding timer, and counter present values will cause problems in systems with long power interruptions.	ZEN-BAT01
Training Kit	An education kit for the ZEN. Contains the following products and manuals. ZEN-10C1AR-A CPU Unit ZEN-SOFT01 ZEN Support Software ZEN-CIF01 Personal Computer Connecting Cable ZEN Operation Manual (W385) Support Software Operation Manual (W386)	ZEN-KIT01

Appendix B

Specifications

General Specifications

Item	Specifications	
Model numbers	LCD type: ZEN-10C1AR-A LED type: ZEN-10C2AR-A	LCD type: ZEN-10C1DR-D LED type: ZEN-10C2DR-D
Power supply voltage	100 to 240 VAC, 50/60 Hz	24 VDC
Allowable power supply voltage	85 to 264 VAC, 47/63 Hz	20.4 to 26.4 VDC
Power consumption	30 VA max.	6.5 W max.
Inrush current	40 A max.	20 A max.
Insulation resistance	20 M Ω (at 500 VDC) min. between power supply AC external terminals and all input terminals, and relay outputs	
Dielectric strength	2300 VAC, 50/60 Hz for 1 min (leakage current 1 mA max.) between power supply AC external terminals and all input terminals, and relay outputs	
Noise immunity	Conforms to IEC61000-4-4, 2 kV (power supply line)	
Vibration resistance	Conforms to JISC0040, 10 to 57 Hz, amplitude 0.075 mm 57 to 150 Hz, acceleration 9.8 m/s ² 80 min in X, Y, and Z directions (Sweep time 8 min x 10 sweeps = 80 mins total.)	
Shock resistance	Conforms to JIS C004, 147 m/s ² 3 times in X, Y, and Z directions	
Ambient temperature	LCD type (with LCD and operation buttons): 0 to 55°C LED type (no LCD/operation buttons): -25 to 55°C	
Ambient humidity	10% to 90% (with no condensation)	
Environmental conditions	No corrosive gases.	
Storage temperature	LCD type (with LCD and operation buttons): -20 to 75°C LED type (no LCD/operation buttons): -40 to 75°C	
Terminal block	Solid-wire terminal block	
Power supply holding time	10 ms min.	2 ms min.
Weight	300 g max.	
Enclosure rating	IP20 (Mounted inside a control panel)	

Characteristics

Item	Specifications	
Control	Stored program	
I/O control	Cyclic scan	
Programming language	Ladder	
Program capacity	96 lines (up to 3 inputs and 1 output per line)	
Maximum control I/O points	34 CPU Unit: 6 input and 4 output points. Expansion I/O Units: 4 input and 4 output points each for up to 3 Units.	
Memory areas	CPU Unit input bits (I)	I0 to I5, 6 bits
	CPU Unit output bits (Q)	Q0 to Q3, 4 bits
	Expansion I/O Unit input bits (X)	X0 to Xb, 12 bits (See note.)
	Expansion I/O Unit output bits (Y)	Y0 to Yb, 12 bits (See note.)
	Work bits (M)	M0 to Mf, 16 bits
	Holding bits (H)	H0 to Hf, 16 bits
	Button switches (B)	B0 to B7, 8 bits (LCD-type CPU Unit only)
	Timers (T)	T0 to T7, 8 timers
	Holding timers (#)	#0 to #3, 4 timers
	Weekly timers (@)	@0 to @7, 8 timers (CPU Units with built-in calendar and clock only)
	Calendar timers (*)	*0 to *7, 8 timers (CPU Units with built-in calendar and clock only)
	Counters (C)	C0 to C7, 8 counters
	Display bits (D)	D0 to D7, 8 bits (LCD-type CPU Unit only)
	Analog comparator (A)	A0 to A3, 4 comparators (CPU Units with DC power supply only)
Comparator (P)	P0 to Pf, 16 comparators	
LCD	12 columns x 4 lines, with backlight (LCD-type CPU Unit only)	
Operation buttons	8 (4 Cursor Keys, 4 operation keys) (LCD-type CPU Unit only)	
User program backup	Internal EEPROM, Memory Cassette (optional)	

Item	Specifications
Power interruption hold	Internal RAM: Super capacitor (or optional battery) for holding bits and timer/counter present values. Calendar and clock: Super capacitor (or optional battery) for date, day, and time. Holding time for super capacitor: 2 days max. (25°C)
Calendar and clock function	Available for ZEN-10C1□□-□ only. Precision: 1 to -2 min/month (25°C)

Note Available when an Expansion I/O Unit is connected.

Input Specifications

CPU Unit

AC Inputs (Not Isolated)

Item	Specifications	Circuit drawing
Input voltage	100 to 240 VAC +10%, -15%, 50/60 Hz	
Input impedance	680 kΩ	
Input current	0.15 mA/100 VAC, 0.35 mA/240 VAC	
ON voltage	80 VAC min.	
OFF voltage	25 VAC max.	
ON response time	50 ms or 70 ms at 100 VAC (See note.)	
OFF response time	100 ms or 120 ms at 240 VAC (See note.)	

Note Can be selected using the input filter settings.

DC Inputs IN0 to IN3 (Not Isolated)

Item	Specifications	Circuit drawing
Input voltage	24 VDC +10%, -15%	
Input impedance	4.8 kΩ	
Input current	5 mA, Typical	
ON voltage	16.0 VDC min.	
OFF voltage	5.0 VDC max.	
ON response time	15 ms or 50 ms (See note.)	
OFF response time		

Note Can be selected using the input filter settings.

DC Inputs IN 4 and IN5 (Not Isolated)

Item		Specifications	Circuit drawing
DC inputs	Input voltage	24 VDC +10%, -15%	
	Input impedance	5 kΩ	
	Input current	5 mA, Typical	
	ON voltage	16.0 VDC min.	
	OFF voltage	5.0 VDC max.	
	ON response time	15 ms or 50 ms (See note.)	
	OFF response time		
Analog inputs	Input range	0 to 10 V	
	External input impedance	150 kΩ min.	
	Resolution	0.1 V (1/100 FS)	
	Overall accuracy (-25°C to 55°C)	10% FS	
	AD conversion data	0 to 10.5 V	

Note Can be selected using the input filter settings.

Expansion I/O Units

AC Inputs (Photocoupler Isolated)

Item	Specifications	Circuit drawing
Input voltage	100 to 240 VAC +10%, -15%, 50/60 Hz	
Input impedance	83 kΩ	
Input current	1.2 mA/100 VAC, 2.9 mA/240 VAC	
ON voltage	80 VAC min.	
OFF voltage	25 VAC max.	
ON response time	50 ms or 70 ms at 100 VAC (See note.) 100 ms or 120 ms at 240 VAC (See note.)	
OFF response time		

Note Can be selected using the input filter settings.

DC Inputs (Photocoupler Isolated)

Item	Specifications	Circuit drawing
Input voltage	24 VDC +10%, -15%	
Input impedance	4.7 kΩ	
Input current	5 mA, Typical	
ON voltage	16.0 VDC min.	
OFF voltage	5.0 VDC max.	
ON response time	15 ms or 50 ms (See note.)	
OFF response time		

Note Can be selected using the input filter settings.

Output Specifications (CPU Unit/Expansion I/O Units)

Item	Specifications	Circuit drawing	
Max. switching capacity	250 VAC/8 A (cosΦ = 1) 24 VDC/5 A	<p>Each circuit is made up of an independent common circuit.</p>	
Min. switching capacity	5 VDC, 10 mA		
Relay life	Electrical		Resistive load: 50,000 times Inductive load: 50,000 times (cosΦ = 1)
	Mechanical		10 million times
ON response time	15 ms max.		
OFF response time	5 ms max.		

The life, under the worst conditions, of the output contacts used in ZEN relay outputs is given in the above table. Guidelines for the normal life of the relays is shown in the following diagram.

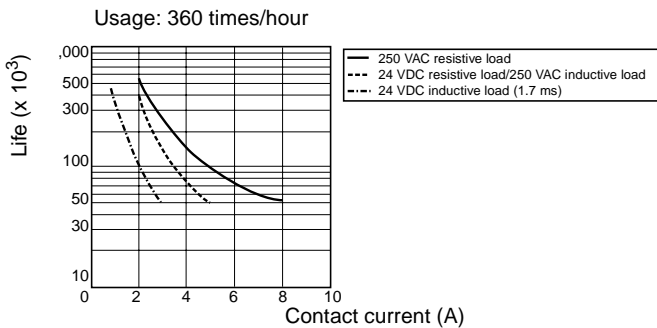

External Dimensions

- CPU Unit (LCD and LED Types)

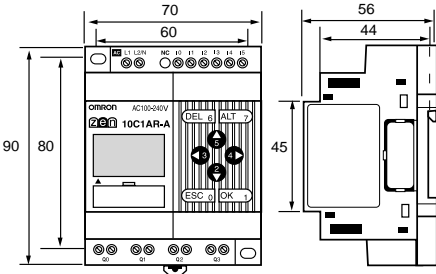

- Expansion I/O Units (4-input/4-output/8 I/O)

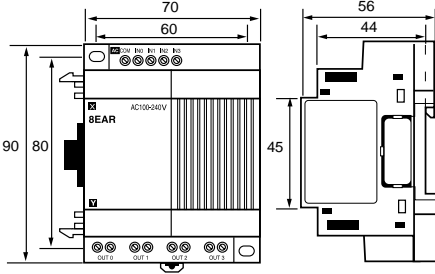

- Unit Mounting Hole Dimensions

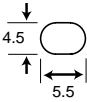

Units: mm

Appendix C

Ladder Program Execution

Executing Ladder Programs

ZEN executes up to 96 lines of a ladder program in one cycle from first to last line. Starting from the first line of the bus bar, the ZEN repeatedly executes each line from left to right.

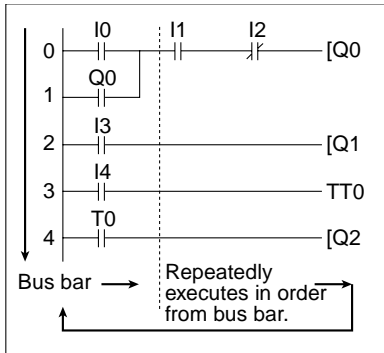

- Note**
1. The time from when processing starts at the bus bar until the bus bar is returned to at the first line again to execute the entire ladder program is called cycle time.
 2. The output ON/OFF results cannot be used for inputs within the same cycle. The result scan be used from the next cycle onwards

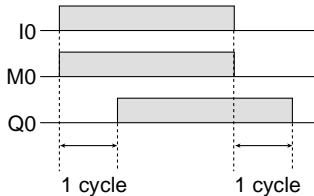
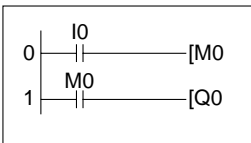

The Q0 ON/OFF result is reflected one cycle after M0 turns ON or OFF.

Ladder Program Execution Time

Refer to the following table for ZEN execution times. The execution times are provided as a guide. External factors, button operations, execution of ZEN Support Software operations, and timing of the processing affects the actual processing times. The cycle time is the sum of the common processing time, the processing time taken when Expansion I/O Units are connected, and the ladder program execution time.

Common Processing Time

Model	Common processing time
ZEN-10C1AR-A	0.85 ms
ZEN-10C1DR-D	
ZEN-10C2AR-A	0.2 ms
ZEN-10C2DR-D	

Expansion I/O Unit Processing Time

0.15 ms/per Expansion I/O Unit.

Ladder Program Execution Time

Per line		25 μ s	*1
Per output	CPU Unit output bits (Q)	4 μ s	*2
	Expansion I/O Unit output bits (Y)		
	Work bits (M)		
	Holding bits (H)		
	Timers (T)/Holding timers (#)		
	Counters (C)	10 μ s	
	Display bits (D)	25 μ s	
Weekly timers (@); per input		3 μ s	*4
Calendar timers (*); per input		2 μ s	
Analog comparators (A); per input		1 μ s	
Comparators (P); per input		15 μ s	*5

Example Calculation of Ladder Program Execution Time

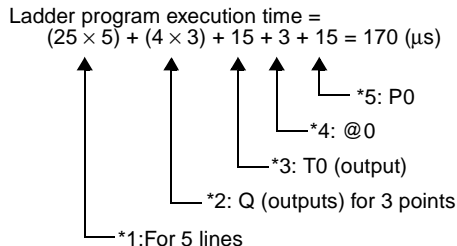
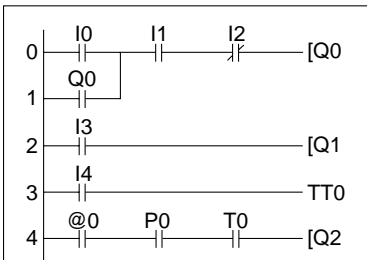

Appendix D

Application Examples

Lighting Pattern Control

Application

The ZEN can help conserve energy if the lighting patterns required for offices and similar environments are set to the ZEN.

Use the switch operation to switch between lighting patterns.

Operation	Switch	Lighting group			
		1 (Q0)	2 (Q1)	3 (Q2)	4 (Q3)
All lights ON	SW 1 (I0)	ON	ON	ON	ON
Pattern 1	SW 2 (I1)	ON	OFF	ON	OFF
Pattern 2	SW 3 (I2)	ON	ON	OFF	OFF
All lights OFF	SW 4 (I3)	OFF	OFF	OFF	OFF

System Configuration

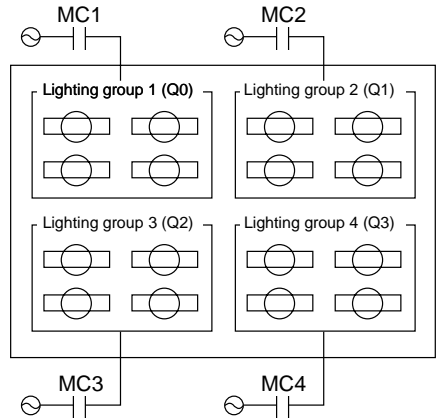
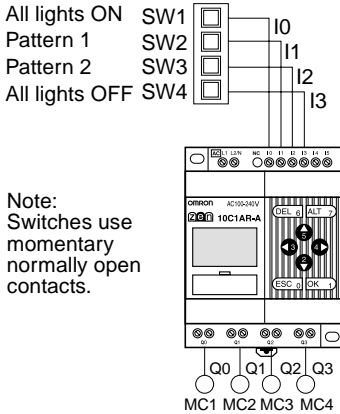

Program Example

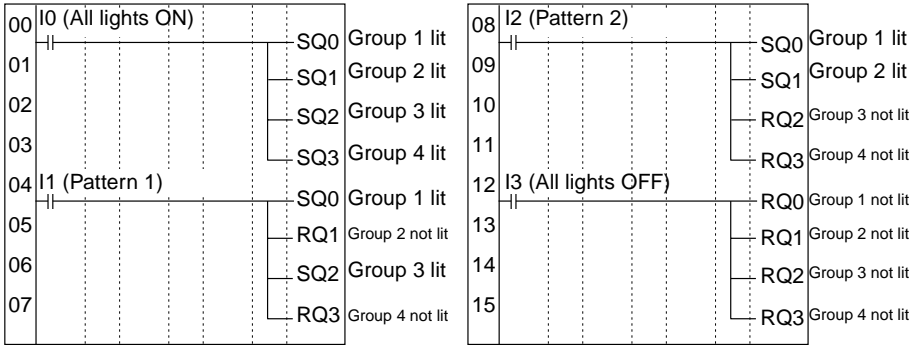

Escalator with Automatic Operation Function (Weekly Timer, OFF Delay Timer)

Application

The ZEN can be simply used to conserve energy for an escalator with an automatic operation function. The escalator can be set to operate continuously from 7:00 to 10:00 and 17:00 to 22:00 weekdays and then operate at other times and on weekends only when people step on the escalator.

System Configuration

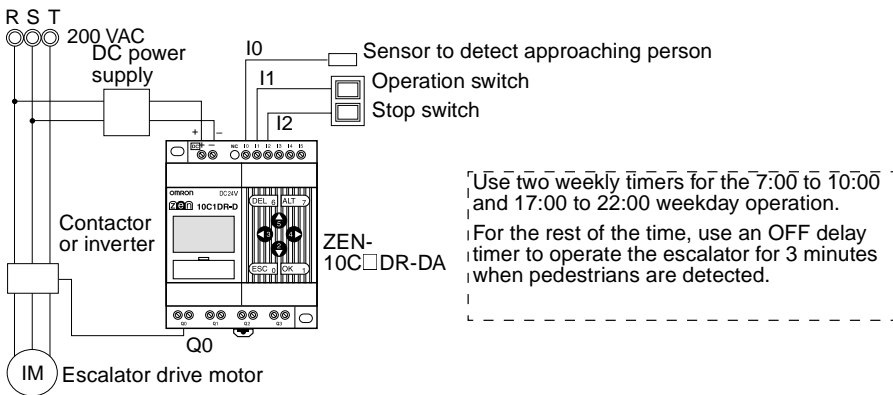

Program Example

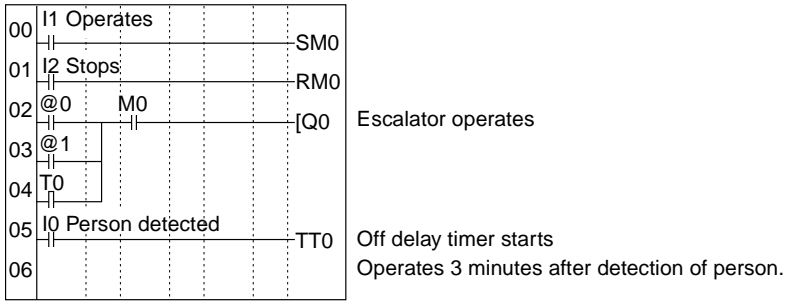

Parameter Settings

Weekly timer @0
(Mon to Fri: 7:00 to 10:00)

```

@0 MO-FR A
ON 07:00
OFF 10:00
    
```

Weekly timer @1
(Mon to Fri: 17:00 to 22:00)

```

@1 MO-FR A
ON 17:00
OFF 22:00
    
```

OFF delay timer T0

```

T0 M:S A
TRG
RES 03.00
    
```

Water Supply Tank Control

Application

Basic water supply control is possible with the 61F Switch (without float) alone, however relay logic is required for inverter control of high-speed operation (when empty) and slow-speed operation (when half-full).

System Configuration

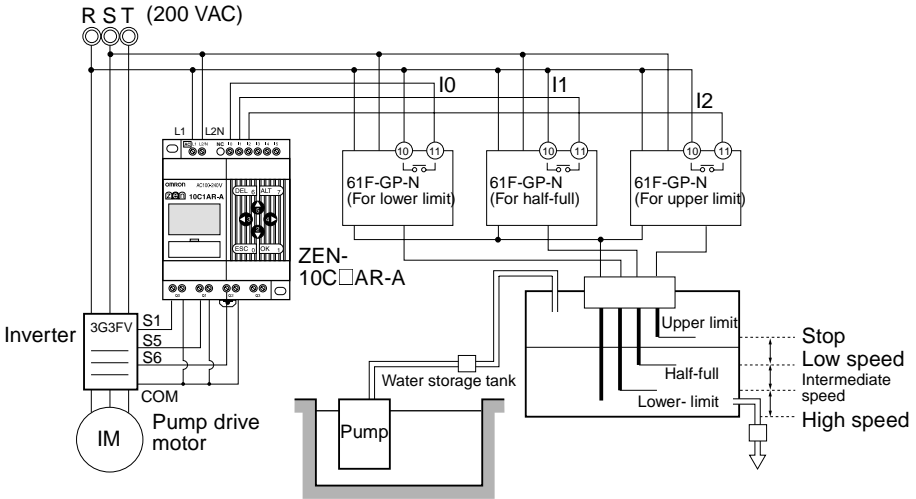

Program Example

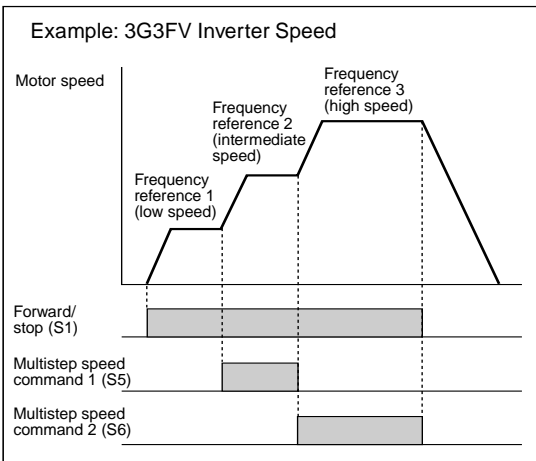
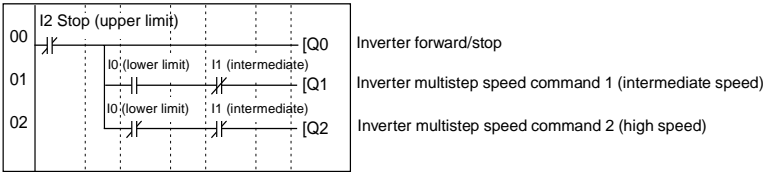

Parameter SettingsOffset Start Timer
Setting T0

T0	X	S	A
TRG			
RES		30.00	

Set to 30 seconds.

Operation timer setting T1

T1	X	H:S	A
TRG			
RES		01.00	

Set to 1 hour.

Operation timer setting T2

T2	X	H:S	A
TRG			
RES		01.30	

Set to 1 hour 30 seconds.

Greenhouse Air Circulation Control (2/3) (Calendar Timer and Weekly Timer)

Application

The ZEN can be used to operate circulation fans during winter nights only.

In this example, the circulation fans operate only at night (19:00 to 6:00) during winter (November 15 to March 20).

During the operation period, the fans operate intermittently, 60 minutes ON, 30 minutes OFF. The low startup current results in a 30 second difference in the fan startup times.

The start and stop operation days during winter (November 15 and March 20) are set using the calendar timer (*0).

The start and stop operation times during the night (19:00 and 6:00) are set using the weekly timer (@0).

The startup time difference and operate/stop cycles are set using the timer (T0 to T2).

System Configuration

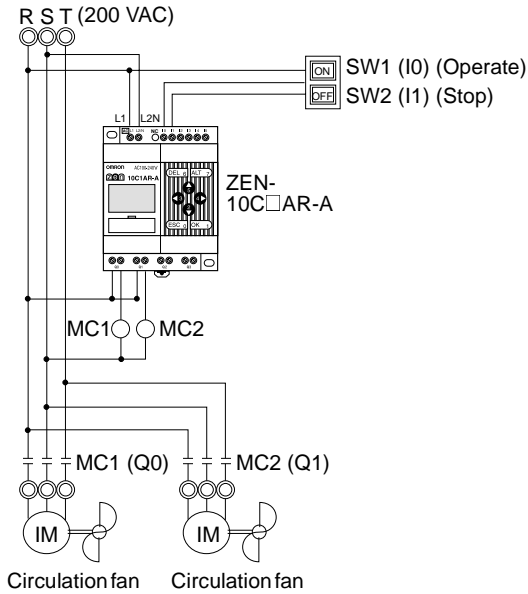

Program Example

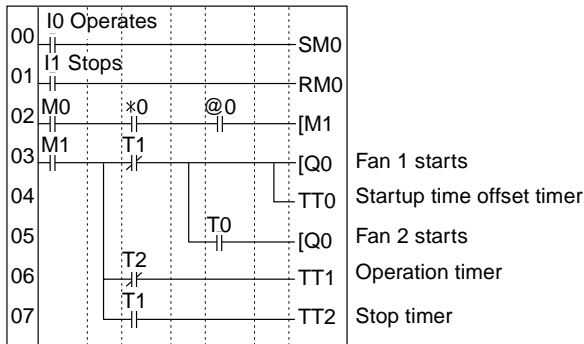

Parameter Settings

Calendar Timer Setting *0

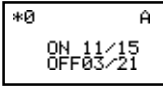

Start Nov 15 and stop Mar 20

Weekly timer setting @0

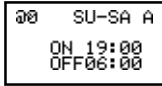

Start at 19:00 and stop at 6:00

Offset startup time setting T0

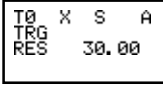

Set to 30 seconds.

Operation time setting T1

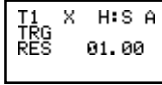

Set to 1 hour.

Stop time setting T2

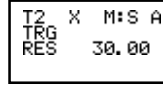

Set to 30 minutes.

Greenhouse Air Circulation Control (3/3) (Analog Comparator)

Application

The ZEN can be used to start the circulation fans once the temperature has reached a set level. A low startup current would result from a difference in the fan startup times.

System Configuration

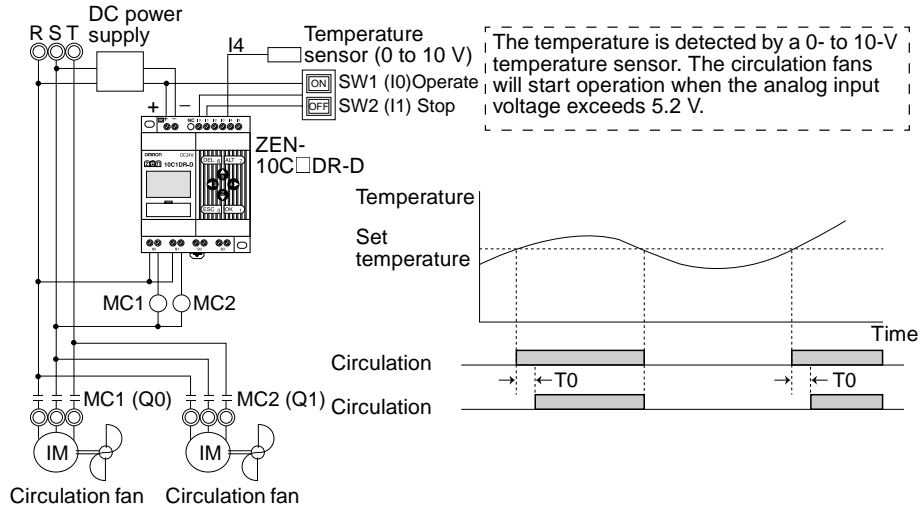

Program Example

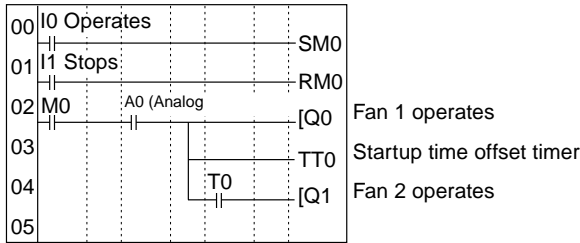

Parameter Settings

Analog Comparator

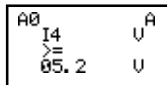

Set temperature ≥ 5.2V

Offset startup timer setting T0

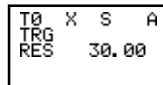

Set to 30 seconds.

Annunciator (Flashing Pulse Timer)

Application

The ZEN can be used to make an alarm light flash when errors occur.

In this example, a flashing pulse timer is used to make an alarm light flash when errors occur. Ladder programs can be created easily when a flashing pulse timer is used.

System Configuration

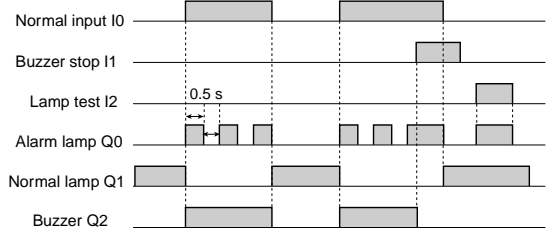
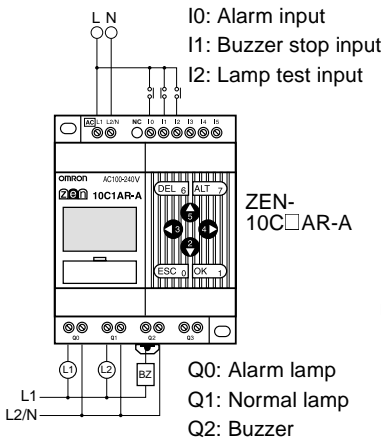

Program Example

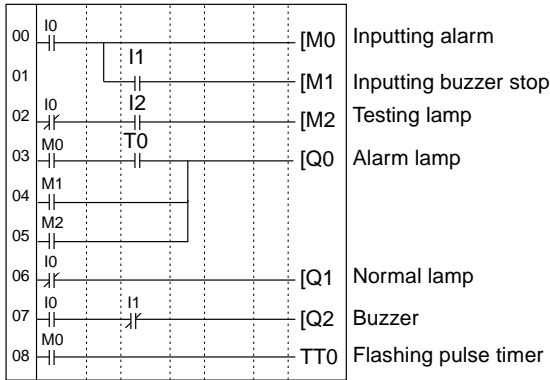

Parameter Settings

Flashing Pulse Timer

T0	F	S	A
TRG			
RES	00.	50	

Set to flash at 0.5 s intervals.

Coin-operated Carwash (Holding Bits and Holding Timer)

Application

The ZEN can be used to change the operating time of a machine, such as a coin-operated car wash, depending on the number of coins inserted.

If a holding timer is used and holding bits used for the self-holding bits, the remaining time will not be reset if there are unexpected power interruptions.

In this example, the carwash operates for 3 minutes if one coin is inserted, 6 minutes if two coins are inserted, and 9 minutes if 3 coins are inserted.

A holding timer is used as the timer.

System Configuration

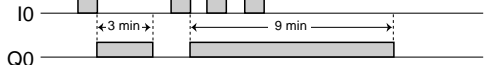
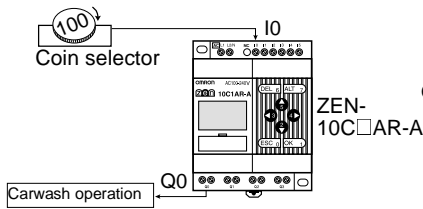

Program Example

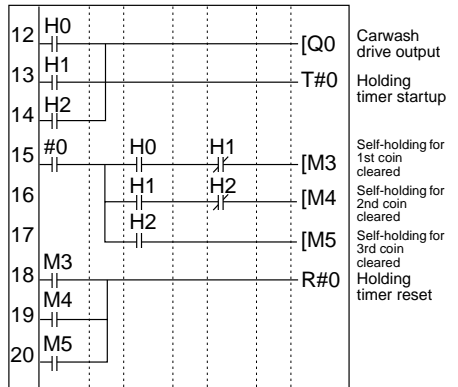
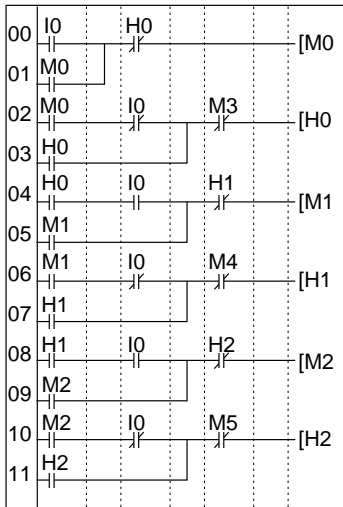

Parameter Settings

Holding Timer

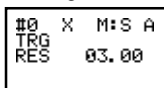

Set to 3 minutes.

Warming Moulding Machines (Weekly Timer and Bit Logic)

Application

The ZEN can be used to improve moulding efficiency by warming up the moulding machine before the work shift starts. This allows moulding work to begin immediately at the start of the work shift.

When work shifts vary, pre-set weekly timers can be selected using a switch.

System Configuration

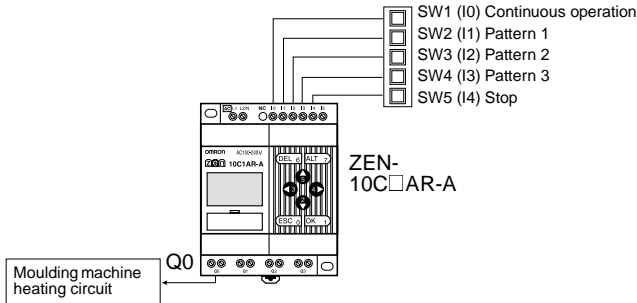

Program Example

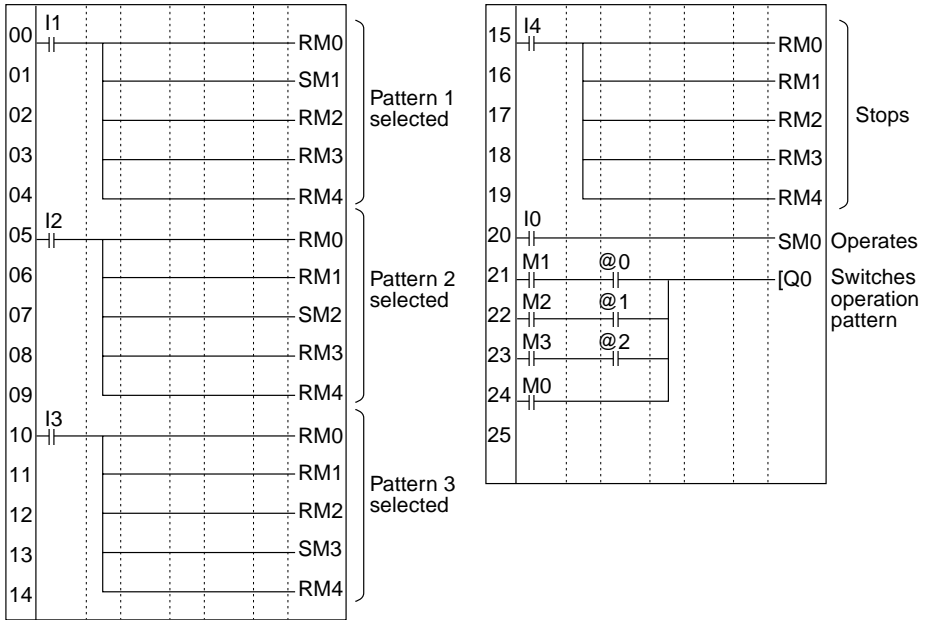

Parameter Settings

Weekly Timer Setting @0 to @2

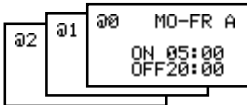

Appendix E

Allocations and Setting Sheets

I/O Allocations

I/O	Unit name	Bit	Input device	Input	IN filter
Input bits	CPU Unit	I0		AC DCV	Yes No
		I1			
		I2			
		I3			
		I4	Normal input Analog voltage input		
	Expansion I/O Unit	X0		AC DCV	Yes No
		X1			
		X2			
	Expansion I/O Unit	X3		AC DCV	Yes No
		X4			
		X5			
		X6			
	Expansion I/O Unit	X7		AC DCV	Yes No
		X8			
		X9			
Xa					
Xb					

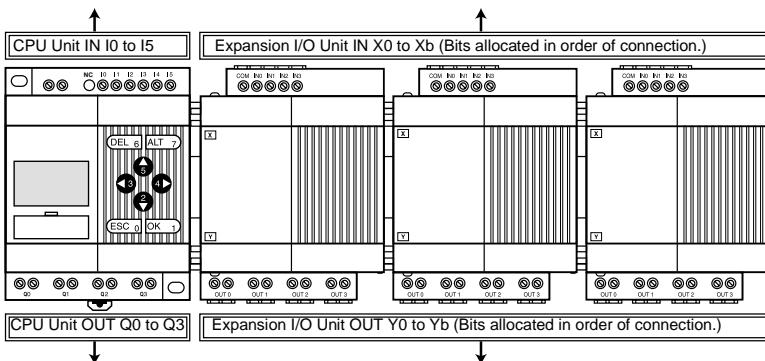

I/O	Unit name	Bit	Output device name and specifications
Output bits	CPU Unit	Q0	AC DC V A
		Q1	AC DC V A
		Q2	AC DC V A
		Q3	AC DC V A
	Expansion I/O Unit	Y0	AC DC V A
		Y1	AC DC V A
		Y2	AC DC V A
		Y3	AC DC V A
	Expansion I/O Unit	Y4	AC DC V A
		Y5	AC DC V A
		Y6	AC DC V A
		Y7	AC DC V A
Expansion I/O Unit	Y8	AC DC V A	
	Y9	AC DC V A	
	Ya	AC DC V A	
	Yb	AC DC V A	

Work and Holding Bit Allocations

Bit type	Address	Application	Bit type	Address	Application
Work bits	M0		Holding bits	H0	
	M1			H1	
	M2			H2	
	M3			H3	
	M4			H4	
	M5			H5	
	M6			H6	
	M7			H7	
	M8			H8	
	M9			H9	
	Ma			Ha	
	Mb			Hb	
	Mc			Hc	
	Md			Hd	
	Me			He	
Mf		Hf			

Timer and Holding Timer Settings

Timer	Address	Operation setting(See note.)	Setting time units	Set time	Application
Timer	T0	X ■ O F	H:M M:S S		
	T1	X ■ O F	H:M M:S S		
	T2	X ■ O F	H:M M:S S		
	T3	X ■ O F	H:M M:S S		
	T4	X ■ O F	H:M M:S S		
	T5	X ■ O F	H:M M:S S		
	T6	X ■ O F	H:M M:S S		
	T7	X ■ O F	H:M M:S S		
Holding timer	#0	X	H:M M:S S		
	#1	X	H:M M:S S		
	#2	X	H:M M:S S		
	#3	X	H:M M:S S		

Note X: ON delay; ■: OFF delay; O: One-shot pulse; F: Flashing pulse

Counter Settings

Counter address	Setting (No. of times)	Application	
C0			Incrementing: Decrementing: Reset:
C1			Incrementing: Decrementing: Reset:
C2			Incrementing: Decrementing: Reset:
C3			Incrementing: Decrementing: Reset:
C4			Incrementing: Decrementing: Reset:
C5			Incrementing: Decrementing: Reset:
C6			Incrementing: Decrementing: Reset:
C7			Incrementing: Decrementing: Reset:

Weekly Timer Settings

Weekly timer address	Start day	Stop day	Start time	Stop time	Application
@0	SU MO TU WE TH FR SA	SU MO TU WE TH FR SA None	:	:	
@1	SU MO TU WE TH FR SA	SU MO TU WE TH FR SA None	:	:	
@2	SU MO TU WE TH FR SA	SU MO TU WE TH FR SA None	:	:	
@3	SU MO TU WE TH FR SA	SU MO TU WE TH FR SA None	:	:	
@4	SU MO TU WE TH FR SA	SU MO TU WE TH FR SA None	:	:	
@5	SU MO TU WE TH FR SA	SU MO TU WE TH FR SA None	:	:	
@6	SU MO TU WE TH FR SA	SU MO TU WE TH FR SA None	:	:	
@7	SU MO TU WE TH FR SA	SU MO TU WE TH FR SA None	:	:	

Calendar Timer Settings

Calendar timer address	Start date	Stop date	Application
*0			
*1			
*2			
*3			
*4			
*5			
*6			
*7			

Analog Comparator Settings

Analog comparator address	Comparison data 1		Operator	Comparison data 2	
	Inputs	Input device and specifications		Input/ No. of points	Input device and specifications
A0	14 I5		≤ ≥	I5 Constant (. V)	
A1	14 I5		≤ ≥	I5 Constant (. V)	
A2	14 I5		≤ ≥	I5 Constant (. V)	
A3	14 I5		≤ ≥	I5 Constant (. V)	

Comparator Settings

Comparator address	Comparison data 1		Operator	Comparison data 2		
	Type	Content		Type	Content	Constant
P0	T□ #□ C□		≤ ≥	T□ #□ C□		
P1	T□ #□ C□		≤ ≥	T□ #□ C□		
P2	T□ #□ C□		≤ ≥	T□ #□ C□		
P3	T□ #□ C□		≤ ≥	T□ #□ C□		
P4	T□ #□ C□		≤ ≥	T□ #□ C□		
P5	T□ #□ C□		≤ ≥	T□ #□ C□		
P6	T□ #□ C□		≤ ≥	T□ #□ C□		
P7	T□ #□ C□		≤ ≥	T□ #□ C□		
P8	T□ #□ C□		≤ ≥	T□ #□ C□		
P9	T□ #□ C□		≤ ≥	T□ #□ C□		
Pa	T□ #□ C□		≤ ≥	T□ #□ C□		
Pb	T□ #□ C□		≤ ≥	T□ #□ C□		
Pc	T□ #□ C□		≤ ≥	T□ #□ C□		
Pd	T□ #□ C□		≤ ≥	T□ #□ C□		
Pe	T□ #□ C□		≤ ≥	T□ #□ C□		
Pf	T□ #□ C□		≤ ≥	T□ #□ C□		

Display Function Settings

Display bit address	Backlight/Display function display screen switching	Display start position	Display message	Application
D0	L0 L1 L2 L3	X: Y:		
D1	L0 L1 L2 L3	X: Y:		
D2	L0 L1 L2 L3	X: Y:		
D3	L0 L1 L2 L3	X: Y:		
D4	L0 L1 L2 L3	X: Y:		
D5	L0 L1 L2 L3	X: Y:		
D6	L0 L1 L2 L3	X: Y:		
D7	L0 L1 L2 L3	X: Y:		

	Backlight	Display function display screen switching
L0	No	No
L1	Yes	No
L2	No	Yes
L3	Yes	Yes

Index

A

- additional functions for bit outputs 24
- allocations
 - allocation sheets 113
 - I/O allocations 26
- alternate operation 25, 43
- analog I/O 60
- application
 - examples 99
- available models 89

B

- backlight
 - changing automatic cutout time 76
- Battery Unit 12
 - mounting 80
- blank lines
 - deleting 51
- button switches 14
 - using 68

C

- calendar timers 58
- characteristics 92
- CLOCK 37
- comparators
 - addresses 42
 - analog 60
 - comparing present values 63
- connection lines 45
 - deleting 50
- contrast
 - adjusting 77
- control panel
 - mounting 30

- counters
 - addresses 25, 42, 44
 - comparing values 63
 - using 54
- CPU Units
 - available models 89
 - overview 2
 - specifications 93, 95

D

- date
 - setting 37
- dimensions 30, 96
- DIN track 27
 - mounting 30
- display bits
 - addresses 25, 44
 - displaying messages 66
- display language 36
- display screen 13

E

- EC Directives xvi
- error messages
 - deleting 88
 - meaning 86
- Expansion I/O Units 13
 - available models 90
 - connecting 31
 - overview 2
 - specifications 94, 95

F

- features 8
- flashing pulse timer 52

H

holding timers 51

I

I/O bits

allocation 26

inputs

analog 60

changing 49

deleting 50

input bits 24

input filter 74

stabilizing input operations 74

wiring input lines 32

writing 41

installation 30

internal holding bits 24

L

Ladder Program Edit Screen settings

analog inputs 61

calendar timers 59

comparing present values 63

counters 55

display bits 66

timers and holding timers 53

weekly timers 57

ladder programs

See programs

language

selecting display language 36

lines

inserting 50

M

memory

backup xx

memory areas 24, 42, 43

Memory Cassettes 9

mounting 81, 82

transferring programs 82

MONITOR 48

mounting 30

Battery Units 80

N

node addresses

setting 84

O

OFF delay timer 52

ON delay timer 52

one-shot pulse timer 52

operating mode 48

at startup xix

RUN mode 15, 17

STOP mode 15, 17

operation

confirming 47

preparation 27

operation buttons 10, 14

optional products 90

outputs

changing additional bit output functions 49

deleting 50

output bits 24

wiring output circuits 33

writing 43

overview 2

P

PARAMETER 17

Parameter Monitor Screen Display

analog comparators 62

calendar timers 60

comparing present values 65

- counters 56
- timers and holding timers 54
- weekly timers 58
- Parameter Settings Screen settings
 - analog comparators 62
 - calendar timers 59
 - comparing present values 64
 - counters 56
 - display bits 67
 - timers and holding timers 53
 - weekly timers 57
- part names 10
- password
 - deleting 73
 - setting 73
- power supply
 - wiring 32
- precautions
 - applications xiii
 - operating environment xvi
 - safety xii
- Programming Device
 - available models 89
- programs
 - clearing 39
 - correcting 49
 - creating 38
 - examples 99
 - executing 97
 - execution time 98
 - protecting 72
 - writing 39

R

- reset input 53, 54
- reset operation 24, 43

S

- screen

- adjusting LCD screen contrast 77
- set operation 24, 43
- settings
 - setting sheets 113
- specifications
 - general 91
 - input 93
 - output 95
- summertime
 - setting 77
- Support Software 4
 - connecting 83
- switching capacity 95
- system configuration 8
- system information
 - reading 78

T

- time
 - setting 37
- timers 51
 - addresses 25, 42, 44
 - calendar timers 58
 - comparing values 63
 - flashing pulse timer 52
 - OFF delay timer 52
 - ON delay timer 52
 - one-shot pulse timer 52
 - weekly timers 56
- trigger input 51
- troubleshooting 86

W

- weekly timers 56
- wiring 31
 - I/O 38
- work bits 24

Revision History

A manual revision code appears as a suffix to the catalog number on the front cover of the manual.

Cat. No. W385-E1-1



Revision code

The following table outlines the changes made to the manual during each revision. Page numbers refer to the previous version.

Revision code	Date	Revised content
1	March 2001	Original production

