



Address:  
Telephone:  
Fax:  
Email:  
Website:

Midas Displays, Electra House, 32 Southtown Road, Great Yarmouth, Norfolk, NR31 0DU  
+44 (0)1493 602602  
+44 (0)1493 665111  
sales@midasdisplays.com  
www.midasdisplays.com

## Specification

# MCT035M6S320480PMLC

---



## Table of Contents

1.0	General Description	3
2.0	Electrical Characteristics	3
3.0	Mechanical Parameters	3
4.0	Pin Definition	3
5.0	Interface Design	4
6.0	Control Command	4
7.0	Outline Drawing	7
8.0	User's Guide	8
9.0	Reliability Test Items	10
10.0	Package Specification	10



## 1.0 General Description

1. The bottle neck of MCU speed is solved: compared with the black and white module, the data volume of color screen is much larger and require rapid data refresh while updating interface, which cannot be satisfied by traditional MCU, otherwise the responding speed of whole system will be very slow.
2. The data storage space of common MCU is within 64K, which is not enough to store one picture for TFT displays; our module adopts an 2Mbyte-8Mbyte FLASH to store picture data and this is quite enough for common interface design.
3. The technology of TFT displays change quickly and the driver IC updating fast, the product life time can't be guaranteed. The software and hardware is required to change often in order to adopt the new displays, which brings a lot of extra work. Our solution can help customer to solve the problem, when there is screen change, we can adopt it on our mainboard, the consumer don't need to changing their software and hardware.
4. The adoption of alphabetic string command for module control is simple and clear; only need MCU output "Hello World" from the UART
5. The RAM on the module is virtualized as a USB flash disk, the user copy pictures from computer to the module, saving a lot of work like general modeling and compiling etc. and development time is shortened.



## 2.0 Electrical Parameters:

Name	spec	note
Input voltage	5V±5%	
Current	<200mA	Backlight on
Color Depth	6 K colors	
Operating Temperature	0----50°C	
Storage Temperature	-30----80°C	
Luminance	300cd/m <sup>2</sup> (type)	
Display Mode	Transmissive	

## 3.0 Mechanical Parameters (mm)

ITEM	spec	note
Size of panel	82.94*54.66	320*480 Dots
Size of module	93.50*69.00*13max	
Size (VA)	74.80*50.50	

## 4.0 Pin Definition

J1 on module is communication port and K1 is reset key.

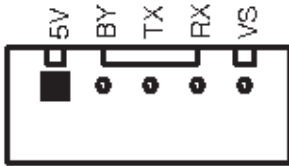

## 5.0 Interface Design:

1. Firstly, put all pictures needed into the folder of BMP\_FILE, convert them into BMP format and change picture names in proper sequence from 000.BMP. The operation can be completed with software of ACDSEE; see [Appendix I](#) for details in operation.

The picture files with names in proper sequence are shown in figure below:

000. bmp	83 KB	Windows Bitmap	240x117x24b
001. bmp	83 KB	Windows Bitmap	240x117x24b
002. bmp	83 KB	Windows Bitmap	240x117x24b
003. bmp	83 KB	Windows Bitmap	240x117x24b
004. bmp	83 KB	Windows Bitmap	240x117x24b
005. bmp	83 KB	Windows Bitmap	240x117x24b
006. bmp	282 KB	Windows Bitmap	240x400x24b

2. Execute batch processing command MakeDAT.bat and three files will be generated in the folder of BMP\_DATA after execution, among which BMPDATA.BIN is the data file where all picture data are put successively and TABLE.BIN is the table file equivalent to index file; copy these two files into the folder virtualized by the module and then they are available for use. There are picture serial numbers and corresponding information of picture size in the file of BmpDataBin.h, which is a reference provided to user without the necessity of being copied to USB flash disk.

3. If special character display is required by user, like Chinese or Japanese etc. The software attached in this module can be used for extracting font library; see [Appendix IV](#) for details. (Only for Chinese version) Revise the name of extracted font library file and copy it in to USB flash disk for application; the file name should be changed as HZK.BIN.

4. Note: this USB flash disk is a virtualized one; the file system is regulated for the convenience of application of this module and improvement of picture refreshing speed; please use FAT12 to format the USB flash disk (this is the default format in WinXP); the limit number of files in root directory is 16 and generally there are only font library file, table file and data file; if other files need to be stored by user, it had better to make a new folder for storage of these files.

5. Press K1 key (reset key) on module after all files are copied into USB flash disk and then they are available for use.

## 6.0 Control Command

This module adopts alphabetic string to control all operations.

The command format begins with command word continued with parameter list in which parameters are separated by space and ends with a return character; pay attention that the return character is a must. *When the command is executing, the busy pin is low, and the module can't receive new command, until the busy pin is high.*

“CMD n1 n2.....Return”

The parameters n1, n2... in table below express a 16-bit unsigned integer data and s1, s2...expresses alphabetic string.

### Drawing commands

Function	Command Format	Example	Execution time
Browse Pictures	ALL	"ALL\n"	-
Draw a circle	CIRCLE Xa Ya R C	"CIRCLE 100 100 50 31\n"	4ms
Fill in color	CLR Xa Ya Xe Ye C	"CLR 0 0 100 100 31\n"	5ms
Clear screen	CLS C	"CLS 31\n"	28ms
Cut a picture	CUT Pn Xa Ya Xb Yb Xs Ys	"CUT 1 30 30 0 0 100 100\n"	20ms
Draw a dot	DOT Xa Ya C	"DOT 100 100 31\n"	0.12ms
Draw a frame with linetype and chamfer	FRAME Xa Ya Xe Ye Ds Do C	"FRAME 10 10 200 40 2 3 31\n"	4ms
Draw a line	LINE Xa Ya Xe Ye C	"LINE 10 10 50 50 31\n"	0.7ms
Backlight on	LEDON	"LEDON\n"	4us
Backlight off	LEDOFF	"LEDOFF\n"	4us
Animation	MOT Xa Ya Ps Pe Pt	"MOT 0 0 10 14 100\n"	0.15ms
Animation off	MOFF	"MOFF\n"	4us
Call on PIC	PIC Pn Xa Ya	"PIC 1 30 30\n"	125ms
Draw a rectangle	RECT Xa Ya Xe Ye C	"RECT 10 10 100 100 31\n"	5ms
Get screen size *	SIZE	"SIZE\n"	13ms
Display alphabetic string	STR Xa Ya C Str	"STR 0 0 31 ABCDEF\n"	0.8ms/Char
Display alphabetic string with background color	STB Xa Ya C Cb Str	"STB 0 20 65535 31 ABC\n"	30us/Char

**Note:**

Xa Ya :start x y coordinates

Xe Ye :End x y coordinates

C :color(16bits,RGB 565 )

Cb : Background color

Xb Yb : start end X Y coordinates in livelong PIC

Xs Ys : Need to intercept the size from livelong picture

Ds Do :Length of Solid line/Dotted line

Str :alphabetic string(8x16)

Pn : Pictures serial number(000-999)

R : Radius

Ps : Start animation picture number

Pe : End animation picture number

Pt : Spacing time(step :100ms)

\* Using the command ,there will be a return value format is a "SXY Xsize Ysize\n"

### Configure Commands

Function	Command Format	Example	Time
Set baud rate	BAUD b1 b2	"BAUD 9600 9600\n"	20ms
Demonstrate PIC	DEMO Dt Xa Ya	"DEMO 1000 0 0\n"	20ms
Off demonstrate	DMOFF	"DMOFF\n"	20ms
Change direction Display of panel	TURN Tn	"TURN 90\n"	140ms

**Note:**

b1 b2 denote baud rate

(range:2400,4800,9600,19200,38400,56000,57600,115200)

Dt denote DEMO interval(step 100ms)

Tn Rotation angle (0° 90°)



## 7.0 Outline Drawing

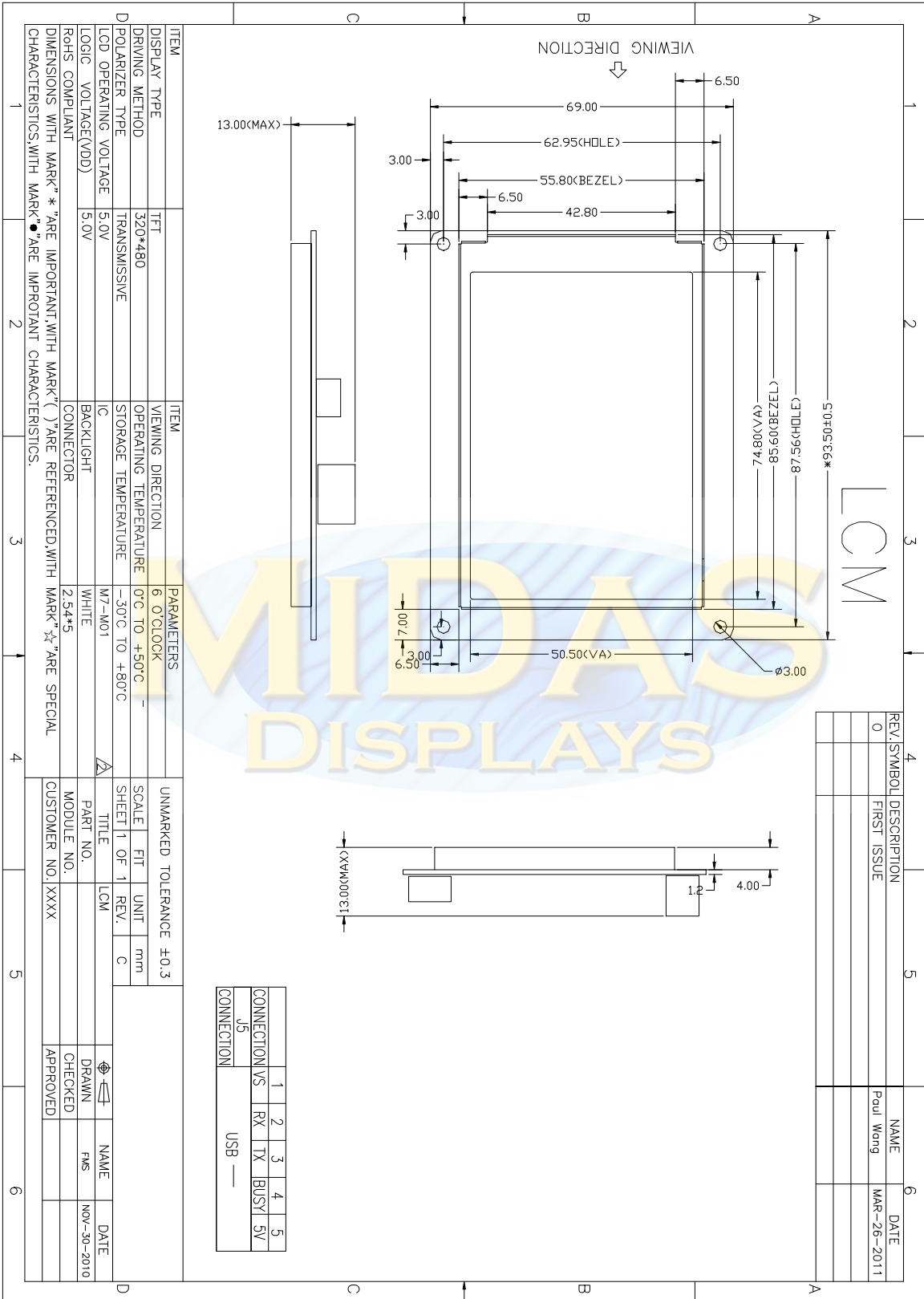

## 8.0 User's Guide

### Appendix I

#### Application of ACDSEE for classifying pictures

1. Collect materials for use into the folder of BMP\_FILE; at the beginning, the pictures may be disordered and the processing of following steps is needed to make them in proper order for operation.



3. Sort the pictures successively beginning with 000.



5. Execute the batch file of MakeDAT.bat



6. After execution, there are three files generated in BMP\_DATA, wherein BMPDATA.BIN is data file in which all picture data are put inside in order; TABLE.BIN is table file equivalent to index file. Copy these two files into the folder virtualized the module and then they are available for use. There are picture serial numbers in the file of BmpDataBin.h corresponding to picture size information as a reference provided to user which is unnecessary to be copied into USB flash disk.

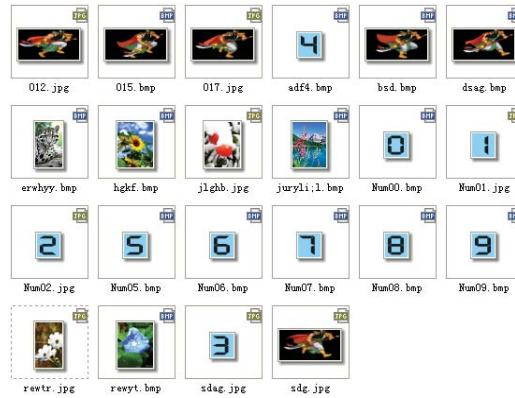

2. Convert all files into BMP format.



4. Reorder the special picture sequence, for instance, the animation part and special font part must be continuous.



**Appendix II**  
Application circuit

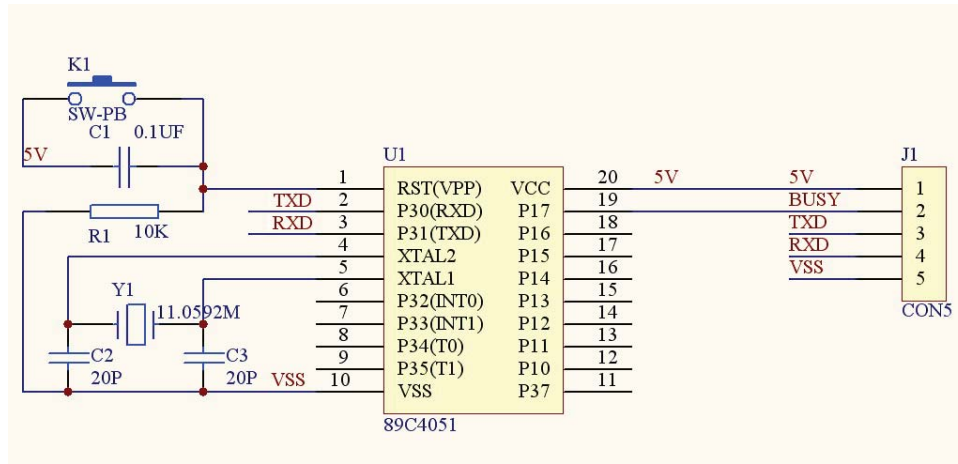

## 9.0 Reliability Test Items

No	Item	Condition	Quantity
1	High Temperature Operating	70°C, 96Hrs	5
2	Low Temperature Operating	-20°C, 96Hrs	5
3	High Humidity	60°C, 90%RH, 96Hrs	5
4	High Temperature Storage	80°C, 96Hrs	5
5	Low Temperature Storage	-40°C, 96Hrs	5
6	Thermal shock	-20°C, 30min~70°C, 30min, 20 cycles.	5

Note1. No defection cosmetic and operational function allowable.



## 10.0 Package Specification TBD

Specification Issue 1 28/8/2012

# SERIAL TFT MODULE APPLICATION NOTE 1

Compiling and transferring image files via the USB interface.



Date	Description of change
26/6/12	Initial creation
28/8/12	Updated Procedure section 7

## Overview

The Midas range of serial TFT modules offer the ability to store images which are then selected for display using serial commands. This overcomes the need to transfer large amounts of data over the serial interface. The following application note describes how to prepare image files and transfer them to the display module flash memory drive via the USB interface.

## Hardware/Software Required

Midas Serial TFT display module.

USB cable type A to mini B.

BmpToBin application software (see link below).

<http://bit.ly/11K8dal>

**Important Note:** (Please be aware that when using this link a warning page will appear, please ignore this and continue by clicking on the link below the 'continue at your own risk' notification).

## Procedure

- 1) Create two directories one called BMP\_DATA and the other BMP\_FILE .

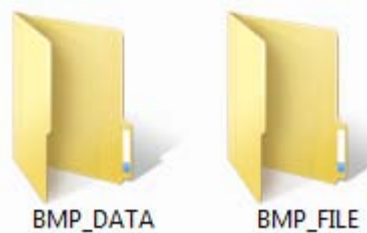

- 2) Place all the bitmap files you require for your project in the BMP\_FILE directory. Note that the files must be 24-bit bitmap type.

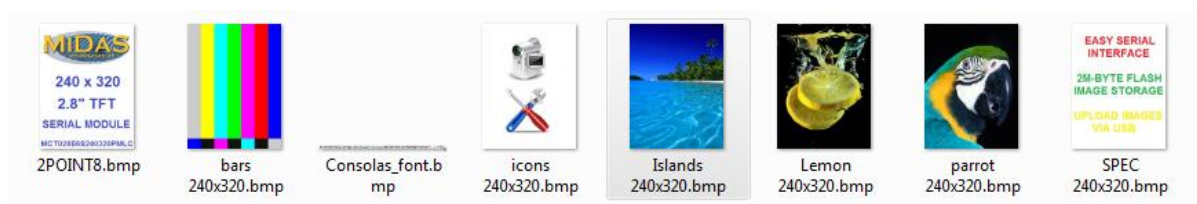

Note that the size of the combined images must not be greater than 2M bytes. This is the sum of  $x*y*2$  for each image. I.e. For the above

$$(240*320*2)+(240*320*2)+(240*320*2)+(240*320*2)+(240*320*2)+(240*320*2)+(240*320*2)+(1315*32*2)=1159360$$

- 3) Re-name each image numerically in the sequence required bearing in mind that any short animation sequences need to be in sequential order. i.e:



- 4) Exit this directory and place the BmpToBin application file in the parent directory i.e

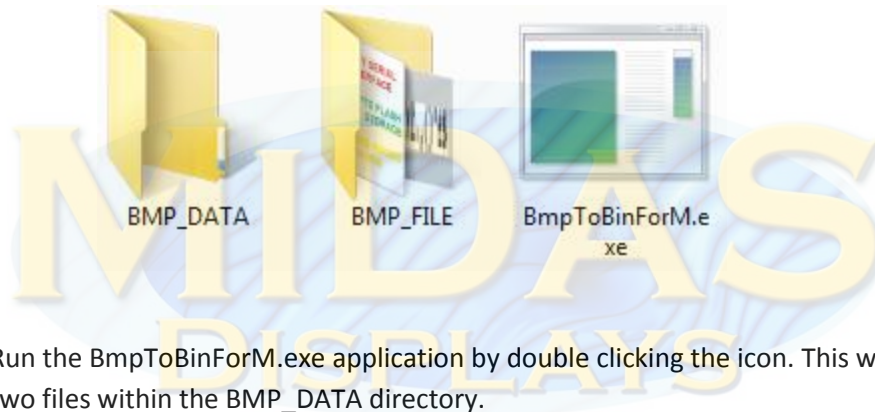

- 5) Run the BmpToBinForM.exe application by double clicking the icon. This will then create two files within the BMP\_DATA directory.

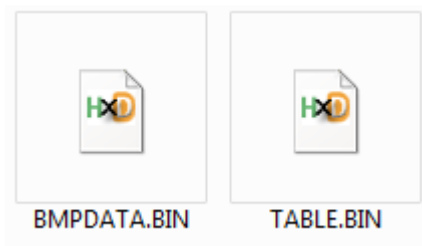

- 6) Plug the TFT module into your PC using a USB A to mini B cable. The module should then appear on your PC as a flash memory device.



7) Simply Copy the two files BMPDATA.BIN and TABLE.BIN created earlier to the module flash drive. These images are then available to be displayed via serial command. If there are already files on the module flash drive you may want to back them up to your PC. You can now via the serial interface view the images on the display module using commands such as: Browse Pictures, Cut a Picture, Animation, Call on PIC and Run Demo.

Notes:

- a) If a demo is already running, delete the files and power off and on before loading new files.
- b) After loading new files wait approximately 1 minute for the unit to program the flash memory before disconnecting power.

## Command Summary

Commands are sent to the board via the Serial UART (TTL levels) on J1. The default serial format is 9600,N,8,1. All commands are ASCII characters followed by CR LF (0D0A hex).

Function	Command Format	Example	Busy Low time
Browse Pictures	ALL	"ALL\n"	-
Draw a circle	CIRCLE Xa Ya R C	"CIRCLE 100 100 50 31\n"	4ms
Fill in colour	CLR Xa Ya Xe Ye C	"CLR 0 0 100 100 31\n"	5ms
Clear Screen	CLS C	"CLS 31\n"	28ms
Cut a picture	CUT Pn Xa Ya Xb Yb Xs Ys	"CUT 1 30 30 0 0 100 100 \n"	20ms
Draw a dot	DOT Xa Ya C	"DOT 100 100 31\n"	0.12ms
Draw a frame with line type and chamfer	FRAME Xa Ya Xe Ye Ds Do C	"FRAME 10 10 200 40 2 3 31\n"	4ms
Draw a line	LINE Xa Ya Xe Ye C	"LINE 10 10 50 50 31\n"	0.7ms
Backlight on	LEDON	"LEDON\n"	4us
Backlight off	LEDOFF	"LEDOFF\n"	4us
Animation	MOT Xa Ya Ps Pe Pt	"MOT 0 0 10 14 100\n"	0.15ms
Animation off	MOFF	"MOFF\n"	4us
Call on PIC	PIC Pn Xa Ya	"PIC 1 30 30\n"	125ms
Draw a rectangle	RECT Xa Ya Xe Ye C	"RECT 10 10 100 100 31\n"	5ms
Get screen size *	SIZE	"SIZE\n"	13ms
Display alphabetic string	STR Xa Ya C Str	"STR 0 0 31 Hello World\n"	0.8ms / char
Display alphabetic string with background colour	STR Xa Ya C Cb Str	"STR 0 20 65535 31 Hello World\n"	30us / char
Set baud rate	BAUD b1 b2	"BAUD 9600 9600\n"	20ms
Run demo	DEMO Dt Xa Ya	"DEMO 1000 0 0\n"	20ms
Stop demo	DMOFF	"DMOFF\n"	20ms
Change orientation	TURN Tn	"TURN 90\n"	140ms

Notes:

Xa Ya	:Start x y coordinates.	Xe Ye	:End x y coordinates.
C	:Colour (16 bits,RGB 565).		
Xb Yb	:Start x y coordinates in flash image.	Xs yS	:Size of flash image block.
Ds Do	:Length of solid line / dotted line.	Str	:ASCII String (8x16).
Pn	:Picture number in flash 000-999.	R	:Radius in pixels.
Ps	:Start Picture number.		
Pe	:End picture number.		
Pt	:Time between pictures (step:100ms).		
*	:Returned on RX "STY Xsize Ysize\n"		
b1 b2	:Baud rate (2400,4800,9600,19200,38400,56000,57600,115200)		
Dt	:Time between pictures (step:100ms).		
Tn	:Rotation angle (0,90)		

**Notes:**

Anti-static precautions should be observed whilst handling this product.

Information contained in this publication regarding device applications and the like is provided only for your convenience and may be superseded by updates. It is your responsibility to ensure that your application meets with your specifications.

MIDAS MAKES NO REPRESENTATIONS OR WARRANTIES OF ANY KIND WHETHER EXPRESS OR IMPLIED, WRITTEN OR ORAL, STATUTORY OR OTHERWISE, RELATED TO THE INFORMATION, INCLUDING BUT NOT LIMITED TO ITS CONDITION, QUALITY, PERFORMANCE, MERCHANTABILITY OR FITNESS FOR PURPOSE. Midas disclaims all liability arising from this information and its use. Use of Midas's products as critical components in life support systems is not authorized except with express written approval by Midas. No licenses are conveyed, implicitly or otherwise, under any Midas intellectual property rights.