

## INTRODUCTION

The T4 system is a Category 4 control solution which incorporates safety PLC functionality and a data link facility.

The T4 Series meets the very highest standards for safety – Third Party Approved for compliance to the latest European Standards including BS EN 61496-1 and BS IEC 61496-2. Rated as a Type 4 device the T4 Series is suitable for ALL machine applications including those categorised 'high risk'.

The T4 Series Light Curtain offers a wide range of models for finger, hand, leg and body protection.

It is compact in size and provides many sophisticated control features as standard, including 2 and 3 beam floating blanking for press and press brake applications, external test and auto or latched reset control options. A muting function is also provided.



## INTRODUCTION

**T4 – an innovative Light Curtain system for industrial machinery applications.**

**Typical machine safeguarding applications include:**

- Press brakes
  - Mechanical presses
  - Guillotines
  - Production lines
  - Robots
- 0.5-15 meters range achieved with no range switches
  - Muting inputs
  - Reset input (selectable manual/auto restart)
  - External device monitoring
  - Electronic safety outputs
  - 2 Auxiliary outputs (electronic)
  - Data link supports range of accessories

The T4 light curtain breaks new ground for safety systems. It contains a core technology which is transported to all the new generation of safety products. All T4 devices feature a programmable controller.

The T4 Light Curtain is in fact a programmable controller with inputs and outputs just like a safety programmable logic controller. The Light Curtain beams are a 'built in' sensing unit providing an internal input to the PLC.

The T4 Light curtain is supplied with a data link. This facility may be used to access additional configuration options such as changing timer values or selecting up to 16 additional modes of operation. It also may be used to connect the light curtain to SY4 safety relays or any other T4 compatible devices.

## FEATURES

The T4 light curtain looks like most other light curtains and can be connected up and used in the usual way. It ships with many features as standard as described in the features section. These allow the unit to be used in almost any application.

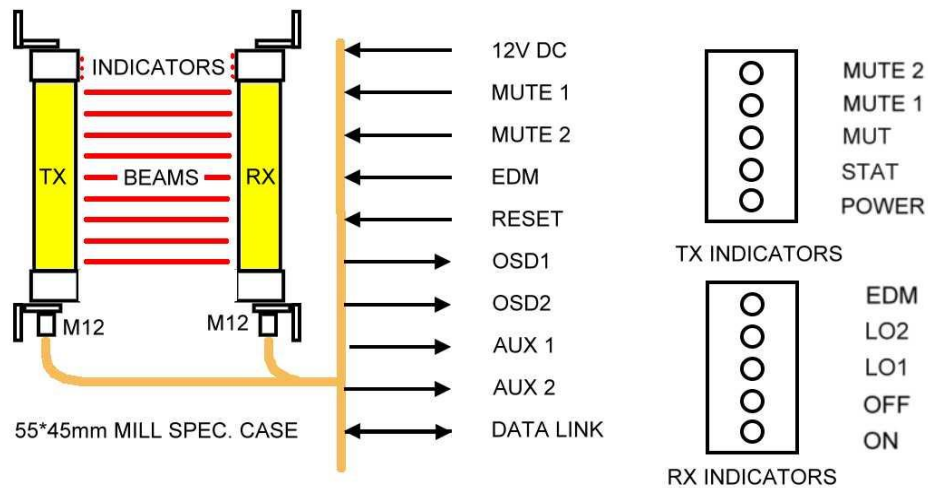

The aluminium extruded case is very robust with a closed cell design. This unique feature separates the sensitive circuits from the plant circuits giving the system outstanding electrical noise immunity while also imparting extremely high torsional strength.

The cables are connected via industry standard M12 connectors to the bottom of the guard.

The indicators are at the top of the guard providing greater visibility.

The robust mounting brackets are made of stainless steel giving many different ways of mounting and adjustment.

There are side slots which may be used in conjunction with a special mounting bracket which clips to a 30mm scaffold pole when a simple floor mount is required.

The unit also features a comprehensive array of LED display lights which give the operations personnel full information as to the state of the guard.

## FEATURES

The reset to start control function is shown in the illustration. The user connections are made via 8 pin M12 connectors to both transmitter and receiver.

The light curtain may be operated in one of 2 modes depending on the way the reset and EDM functions are connected. See Installation Sheet Box E.

The reset to start mode incorporates the reset and EDM function. In this mode the guard requires a reset to close the OSSD's. The guard has a muting feature built in, with timers to facilitate the function when used in packaging applications.

The EDM function monitors the user's safety relay for correct operation.

Additionally there are 2 outputs which allow the user to indicate or monitor the status of the safety outputs or the mute function.

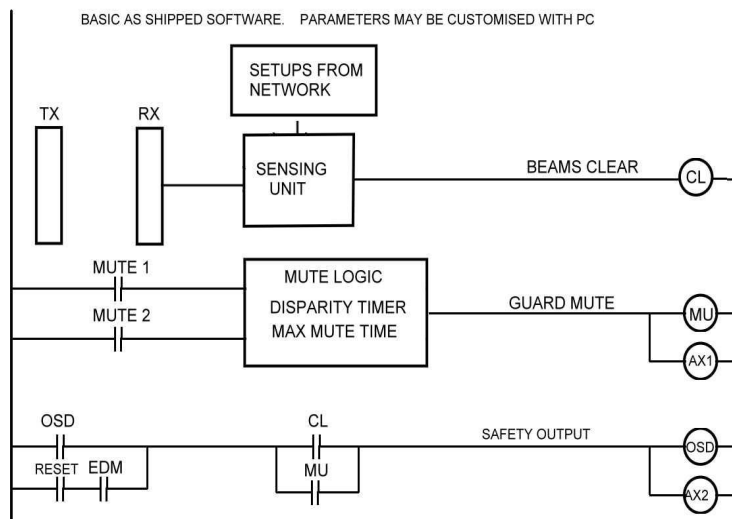

## EXTENDED FEATURES

The design also features an RS232 link as standard.

The link can be used in the following ways:

- 1) Setting basic parameters such as mute timers.
- 2) Selecting an alternative logic function.
- 3) Downloading a new application program.
- 4) Operating a network of up to 24 T4 devices.
- 5) Monitoring the working system with PC.
- 6) Height Measuring.
- 7) Muting Functions

A PC can be directly connected to the data link.

### T4 Components in a Network

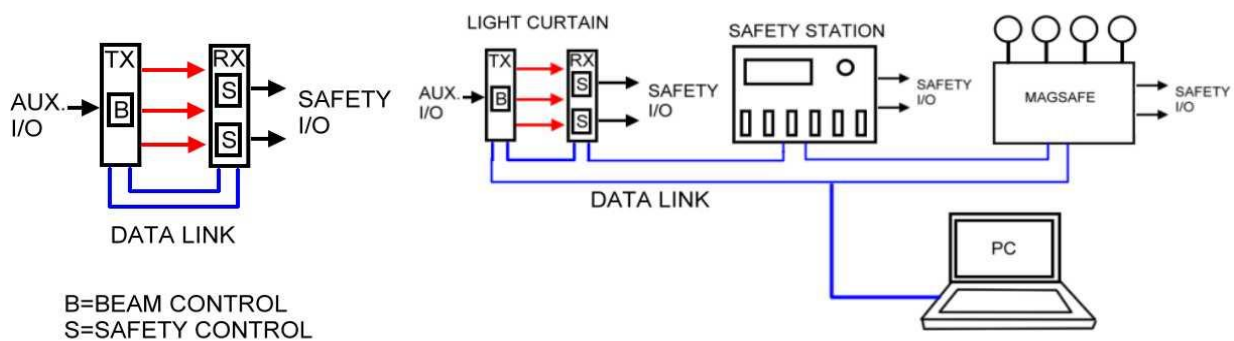

BASIC T4 LIGHT CURTAIN

T4 COMPONENTS IN NETWORK

The network illustration shows how T4 components may be connected together to produce a system. The devices occupy one of 24 nodes in the RS232 network. Any of the devices may be the master with the control program running in it. All devices have access to all the signals in the system.

A PC may form part of the system for problem solving or programming.

The functions shown comprises the default software which runs when the guard is powered up with RESET=0 and EDM=1.

The guard will work in auto-reset mode by powering up with RESET=1 and EDM=0. Mute is still operational and the guard may form a component of an external system which contains a reset function.

## SPECIFICATION

### T4 Series Light Curtains

Number of beams	1 - 128
Detection height	141 – 2391 mm
Range	Perimeter guard - 20 metres 14 mm guard - 5 metres 30 mm guard - 10 metres 40 mm guard - 15 metres
Light type	IR 880nm
Response time	20ms
Operating temperature	0°C to +50°C Heater Off -30°C to +40°C Heater On
Light curtain enclosure	IP65
Power supply	24V DC 2A ±10%
Current consumption	500mA maximum
Light curtain connection	M12 - 8 way pin - IP65
Finish	Aluminium chromate treated, yellow polyester powder coated
Classification	BS EN 61496-1 Type 4 BS IEC 61496-2 Type 4 BS EN 954-1 Category 4 BS EN 61508 SIL 3
Warranty	1 Year

#### OUTPUTS

Safety Outputs OSSD1 & OSSD2	Electronic 50 mA
Status Output	Electronic 50 mA
Mute Output	Electronic 50 mA
Status and Mute Indication	Status & condition LED's on Light Curtain

#### INPUTS

Safety Monitoring (EDM)	ON = +24V DC
Reset	ON = +24V DC 'Reset'
Mode select	Reset - Green = Reset (+) switch Yellow = EDM (+) Auto Reset - Green = L+ Yellow = L-
Muting	Dual Mute Inputs 24V DC = 'on'

## LIGHT CURTAIN MODEL LIST

### T4 Range of Light Curtains 30mm odc (10 metres range)

Model number	Number of beams	Detection height (mm)	Overall length (M) mm	Weight (TX + RX) Kg
050-301	6	141	317	1.15
050-302	12	291	467	1.72
050-303	18	441	617	2.32
050-304	24	591	767	2.88
050-305	30	741	917	3.50
050-306	36	891	1067	4.10
050-307	42	1041	1217	4.70
050-308	48	1191	1367	5.50
050-309	54	1341	1517	5.12
050-310	60	1491	1667	6.62
050-311	66	1641	1817	7.19
050-312	72	1791	1967	7.90
050-313	78	1941	2117	8.50
050-314	84	2091	2267	9.15
050-315	90	2241	2417	9.60
050-316	96	2391	2567	10.47

### T4 Range of Light Curtains 40mm odc (15 metres range)

Model number	Number of beams	Detection height (mm)	Overall length (M) mm	Weight (TX + RX) Kg
050-401	6	141	317	1.15
050-402	12	291	467	1.72
050-403	18	441	617	2.32
050-404	24	591	767	2.88
050-405	30	741	917	3.50
050-406	36	891	1067	4.10
050-407	42	1041	1217	4.70
050-408	48	1191	1367	5.50
050-409	54	1341	1517	5.12
050-410	60	1491	1667	6.62
050-411	66	1641	1817	7.19
050-412	72	1791	1967	7.90
050-413	78	1941	2117	8.50
050-414	84	2091	2267	9.15
050-415	90	2241	2417	9.60
050-416	96	2391	2567	10.47

## LIGHT CURTAIN MODEL LIST

### T4 Range of Light Curtains 14mm odc (5 metres range)

Model number	Number of beams	Detection height (mm)	Overall length (M) mm	Weight (TX + RX) Kg
050-101	16	141	317	1.25
050-102	32	291	467	1.87
050-103	48	441	617	2.57
050-104	64	591	767	3.147
050-105	80	741	917	4.03
050-106	96	891	1067	4.78
050-107	112	1041	1217	5.43
050-108	128	1191	1367	6.29

### T4 Range of Light Curtains for Perimeter Guarding (20 metres range)

Model number	Number of beams	Overall length (M) mm	Weight (TX + RX) Kg
050-602	2 @ 550	767	2.75
050-603	3 @ 450	1067	3.95
050-604	4 @ 400	1367	5.25

### Interconnect Cables

Model number	Length (m)
051-005	5
051-010	10
051-020	20

## CONNECTION INFORMATION

**Note:** Do not disconnect cables from the Transmitter (TX) or Receiver (RX) head with the power still connected to a T4 Series Light Curtain.

### Safety Outputs OSSD1 and OSSD2 (F1)

Two independent electronic switches provide the failsafe outputs for connection to the machine control system. Connections are

Connections are Grey (OSSD1) and Pink (OSSD2) wires on the Receiver (RX) head cable. Outputs 'on' = 24V. (Light curtain clear/protecting) Outputs 'off' = 0V (Light curtain blocked) maximum switching current = 50mA

LED indicators located at the top of the Receiver (RX) head labelled as ON and OFF show the status of the OSSDs.

Green LED's ON = OSSD1 and OSSD2 active ON  
Red LED's ON = OSSD1 and OSSD2 inactive OFF

### Manual / Auto Reset Mode

Manual Reset - The Green wire on the Receiver (RX) head cable to be connected to a 'Normally Open' Reset switch contact block and the other side of the switch contact block needs to be at 24V DC. The Yellow wire on the Receiver (RX) head is used for the EDM (External Device Monitoring) with a normally closed contact of the external device and the other side of the contact to 24V DC. Note: If EDM is not used the Yellow wire must be connected to 24V DC.

Auto Reset – The Green wire on the Receiver (RX) head cable to be connected to 24V DC but if the EDM is required the Green wire will need to be connected to normally closed contact of the external device and the other side of the contact to 24V DC. The Yellow wire needs to be permanently connected to 0V DC.

Note: Changing the condition of the light curtain from manual to auto reset and visa-versa must be done with the power supply in the off-state.

LED indicators located at the top of the Receiver (RX) head labelled as EDM shows EDM status.

Yellow LED ON = EDM ON      Yellow LED OFF = EDM OFF

Note: In auto reset mode the EDM LED is permanently off.

## CONNECTION INFORMATION

### Mute Function

There are 2 wires required to enable the mute function of the light curtain, Green wire (mute 1) and Yellow wire (mute 2) on the Transmitter (TX) head cable. The two mute inputs need to be at 24V DC switching to activate the light curtains mute function. Muting is the condition where the light curtain OSSD outputs will not respond to an interruption to the sensing field of the light curtain.

Both mute inputs are monitored with a disparity of 2 seconds therefore both signals must be supplied to the light curtain within 2 seconds of each other.

When the light curtain is in a mute condition it will activate an internal mute timer with a maximum time period of 15 minutes.

LED indicators located at the top of the Transmitter (TX) head labelled as MU1 (Mute 1), MU2 (Mute 2) and MUT (Light curtain Muted) show the status.

MU1 - Yellow LED ON = Mute 1 ON	Yellow LED OFF = Mute 1 OFF
MU2 - Yellow LED ON = Mute 2 ON	Yellow LED OFF = Mute 2 OFF
MUT - Yellow LED ON = Mute ON	Yellow LED OFF = Mute OFF *

\*An external electronic mute output signal is also available from the Grey wire on the Transmitter (TX) head cable, mute-on = 24 vdc (rated at 24V DC 50mA) and mute-off = 0 vdc. This can be used to drive an external relay for remote indication via a beacon and/or an input to a PLC.

### Status Output

The status output should only be used for non-safety critical application. E.g. connecting an indicator lamp or as feedback to a PLC to conform that the safety outputs have de-energised. The status output, Pink wire on the Transmitter (TX) head cable energises when the safety output OSSDs energise and de-energises when the safety outputs OSSDs de-energises. Status output ON = 24V DC 50mA and OFF = 0V DC

LED indicator located at the top of the Transmitter (TX) head labelled as STAT (Status) shows the condition.

STAT - Yellow LED ON = STATUS ON	Yellow LED OFF = STATUS OFF
----------------------------------	-----------------------------

## CONNECTION INFORMATION

### Power supply

Use a regulated supply +24V DC  $\pm 10\%$ , 0.5A. The White wire on both the Transmitter (TX) and Receiver (RX) head cables are to be connected to 24V DC (L+) and the Brown wire on both the Transmitter (TX) and Receiver (RX) head cables are to be connected to 0V DC (L-).

**Caution:** 0V (L-) of the power supply must be connected to ground.  
No signal should exceed +24V DC  $\pm 10\%$  (L+) or be less than 0V (L-)

**Note:** Any input or output signals not used must be terminated to an individual isolated terminal block.

### Communication Link

The Transmitter (TX) and Receiver (RX) heads communicate via RS232. The Blue wire from the Transmitter (TX) head cable must be connected to the Blue wire from the Receiver (RX) head cable.

The Red wire from the Transmitter (TX) head cable must be connected to the Red wire from the Receiver (RX) head cable.

**Caution:** The Data wires are RS232 levels ( $\pm 10V$ ) and must not be connected to any source that is not RS232 compatible.  
Do not apply 24V DC to the data wires or it will damage the light curtain.