

iglidur® J – The Fast and Slow Motion Specialist



Low wear against different shaft materials

Low coefficients of friction running dry

Vibration dampening

Good chemical resistance

Best material to use with soft shaft materials

Low moisture absorption

iglidur® J

Phone +44 (0) 16 04 - 67 72 40
Fax +44 (0) 16 04 - 67 72 45

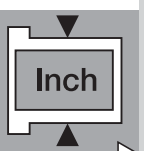
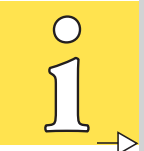



iglidur® J | The Fast and Slow Motion Specialist

The iglidur® J plain bearings are designed for the lowest coefficients of friction while running dry and low stick slip tendency. With a maximum permissible surface pressure of 35 MPa iglidur® J plain bearings are not suitable for extreme loads.

iglidur® J

3 styles
> 250 dimensions
Ø 2–100 mm



Phone +44 (0) 16 04 - 67 72 40
Fax +44 (0) 16 04 - 67 72 45

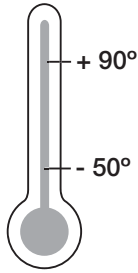

iglus® UK Ltd

Price index



The Fast and Slow Motion Specialist



When to use iglidur® J plain bearings:

- Low wear against different shafts up to 5 MPa
- Low coefficient of friction in dry run
- Vibration dampening
- Good chemical resistance
- Best performance with soft shaft materials
- Low moisture absorption
- For high speeds



When not to use iglidur® J plain bearings:

- When high pressures occur
 - ▶ iglidur® G (chapter 2), W300 (chapter 5)
- When short term temperatures occur that are greater than 120°C
 - ▶ iglidur® G (chapter 2), Z (chapter 22)

Internet www.igus.co.uk
E-mail sales_uk@igus.co.uk



Material Table

General Properties	Unit	iglidur® J	Testing Method
Density	g/cm ³	1,49	
Colour		Yellow	
Max. moisture absorption at 23°C/50% r.F.	% weight	0,3	DIN 53495
Max. moisture absorption	% weight	1,3	
Coefficient of sliding friction, dynamic against steel	μ	0,06 - 0,18	
p x v value, max. (dry)	MPa x m/s	0,34	

Mechanical Properties

Modulus of elasticity	MPa	2.400	DIN 53457
Tensile strength at 20°C	MPa	73	DIN 53452
Compressive strength	MPa	60	
Max. recommended surface pressure (20°C)	MPa	35	
Shore D hardness		74	DIN 53505

Physical and Thermal Properties

Max. long term application temperature	°C	90	
Max. application temperature, short term	°C	120	
Min. application temperature	°C	-50	
Thermal conductivity	W/m x K	0,25	ASTM C 177
Coefficient of thermal expansion (at 23°C)	K ⁻¹ x 10 ⁻⁵	10	DIN 53752

Electrical Properties

Specific volume resistance	Ωcm	> 10 ¹³	DIN IEC 93
Surface resistance	Ω	> 10 ¹²	DIN 53482

Table 3.1: Material Data

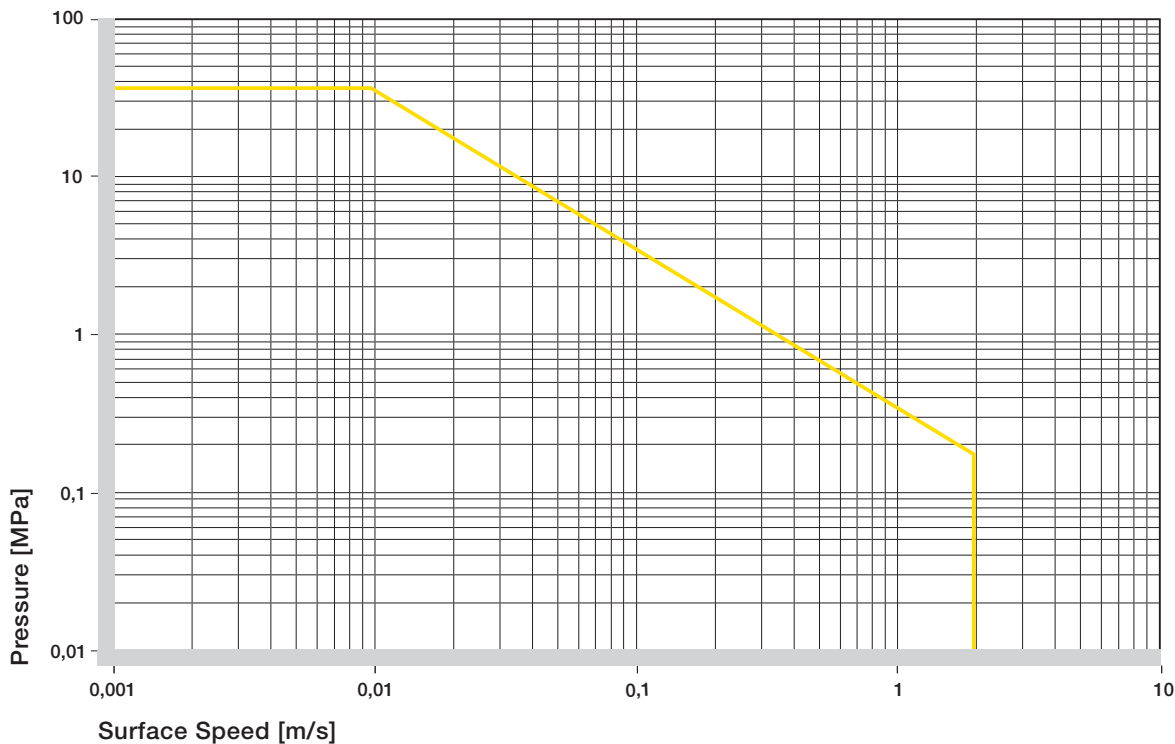

Graph 3.1: Permissible p x v value for iglidur® J running dry against steel shaft, at 20°C

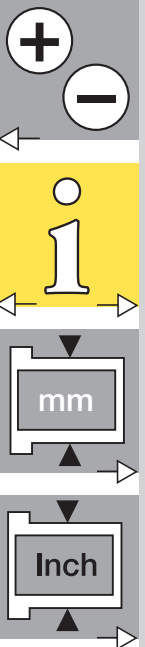

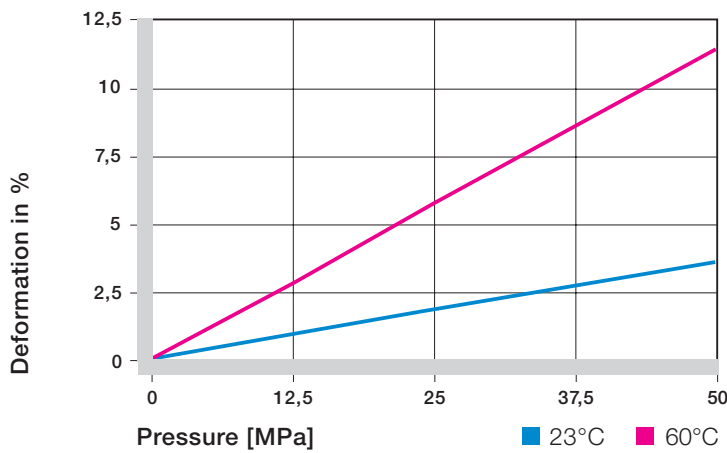

Graph 3.2: Deformation under pressure and temperature

m/s	Rotating	Oscillating	Linear
Continuous	1,5	1,1	8
Short term	3	1,1	10

Table 3.2: Maximum surface speeds

iglidur® J	Application Temperature
Minimum	- 50 °C
Max., long term	+ 90 °C
Max., short term	+ 120 °C

Table 3.3: Temperature limits for iglidur® J

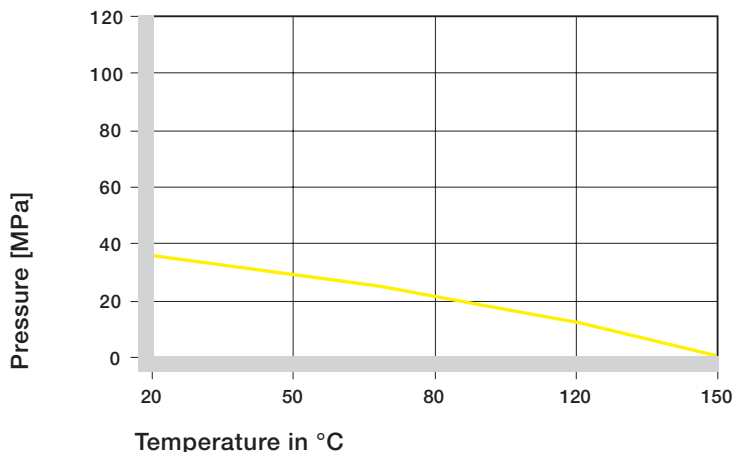

Graph 3.3: Recommended maximum surface pressure of iglidur® J as a function of temperature

iglidur® J	Dry	Grease	Oil	Water
C.o.f. [μ]	0,06 - 0,18	0,09	0,04	0,04

Table 3.4: Coefficients of friction for iglidur® J against steel (Ra = 1 μm, 50 HRC)

One main advantage of iglidur® J plain bearings is the combination of a low coefficient of friction when running dry, the low stick-slip tendency, and the excellent wear rate at low pressure.

Surface Pressure

With a recommended maximum surface pressure of 35 MPa, iglidur® J plain bearings are not suitable for extreme loads. Graph 3.2 shows the elastic deformation of iglidur® J for radial loads. At the recommended maximum surface pressure of 35 MPa the deformation is less than 2.5%.

- ☑ Graph 3.2
- ▶ Surface Pressure, page 1.18

Permissible Surface Speeds

The low coefficient of friction and the extremely low stick slip tendency of iglidur® J plain bearings are especially important at very low speeds. However, iglidur® J material can also be used for high speeds of over 1 m/s. In both cases the static friction is very low and stick slip does not occur.

The maximum values given in Table 3.2 can only be achieved at the lowest pressure loads. At the given speeds, friction can cause a temperature increase to maximum permissible levels. In practice, though, this temperature level is rarely reached, due to varying application conditions.

- ▶ Surface Speed, page 1.20
- ▶ p x v value, page 1.22

Temperatures

iglidur® J plain bearings can be used between -50°C and +90 °C; the short-term maximum permissible temperature is 120°C. Graph 3.3 shows that the compressive strength of iglidur® J plain bearings decreases with increasing temperatures. Also, the wear increases significantly above 80°C.

- ☑ Graph 3.3
- ▶ Application Temperatures, page 1.23



Friction and Wear

Graph 3.5 shows the coefficients of friction for different loads. The level of the coefficient of friction is very good for all loads with iglidur® J.

Friction and wear are also dependent, to a large extent, on the shaft material. With increasing shaft roughness, the coefficient of friction also increases.

The best case is a ground surface with an average roughness $R_a = 0.1 - 0.3 \mu\text{m}$.

- ☑ Graphs 3.4 to 3.6
- ▶ Coefficients of Friction and Surfaces, page 1.25
- ▶ Wear Resistance, page 1.26

Shaft Materials

Graphs 3.7 and 3.9 show results of testing different shaft materials with plain bearings made of iglidur® J.

If iglidur® J plain bearings are used in rotational applications with pressures under 2 MPa, several shaft materials are suitable. A Hard Chromed shaft provides the lowest wear in this range. When compared to most iglidur® materials, iglidur® J has very low wear results at low loads compared with all shaft materials tested.

Also, for increasing pressures up to 5 MPa, the wear resistance of iglidur® J is excellent. Especially suitable is the combination with 303 stainless steel.

In oscillating operation with Cf53 Steel and HR Carbon Steel, the wear of iglidur® J is slightly higher than for rotation. For oscillating movements with loads of 2 MPa, iglidur® J is best combined with Cf53 Steel shaft.

As Graph 3.9 shows, the difference in wear between rotation and oscillating movements is most significant for 303 stainless steel shafts.

If the shaft material you plan to use is not contained in this list, please contact us.

- ☑ Graphs 3.7 to 3.9
- ▶ Shaft Materials, pages 1.28

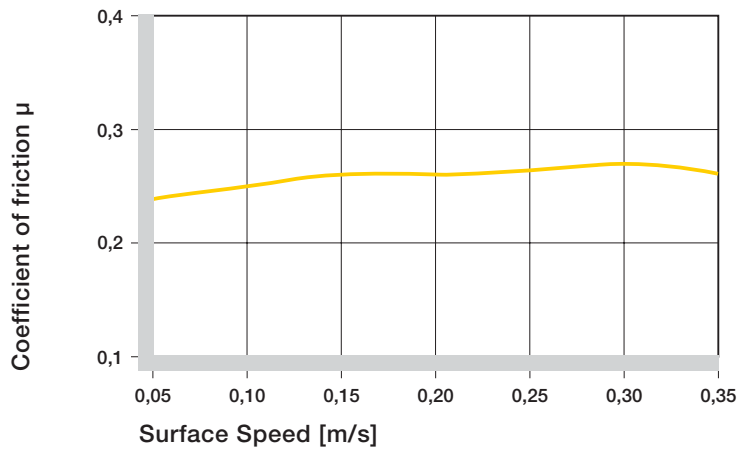

Graph 3.4: Coefficient of friction of iglidur® J as a function of the surface speed; $p = 0.75 \text{ MPa}$

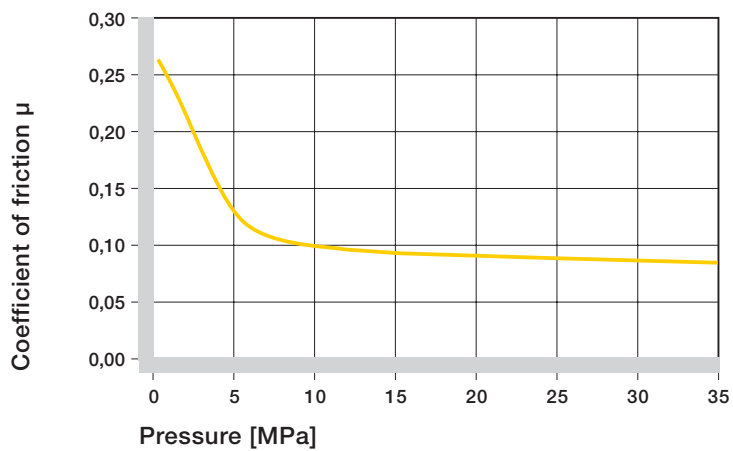

Graph 3.5: Coefficient of friction of iglidur® J as a function of the pressure, $v = 0.01 \text{ m/s}$

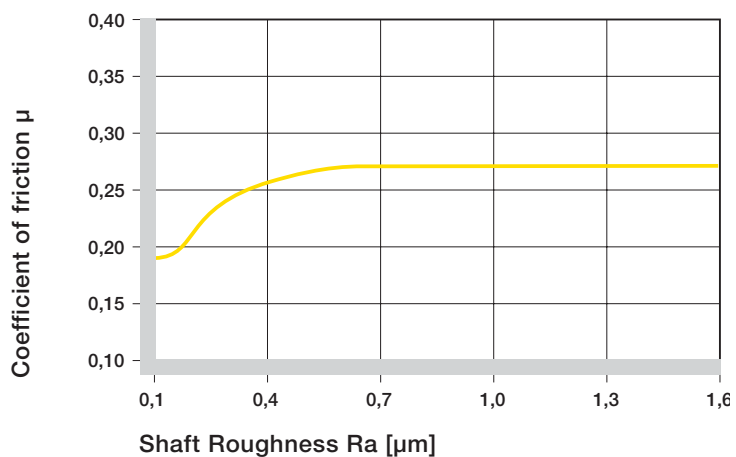

Graph 3.6: Coefficient of friction of iglidur® J as function of the shaft surface (Cf53 hardened and ground steel)

iglidur® J

Phone +44 (0) 1604 - 67 72 40
Fax +44 (0) 1604 - 67 72 45

Navigation icons: Home, Search, Information, Units (mm, Inch)



iglidur® J

Phone +44 (0) 16 04 - 67 72 40
Fax +44 (0) 16 04 - 67 72 45

igus® UK Ltd

Internet www.igus.co.uk
E-mail sales_uk@igus.co.uk

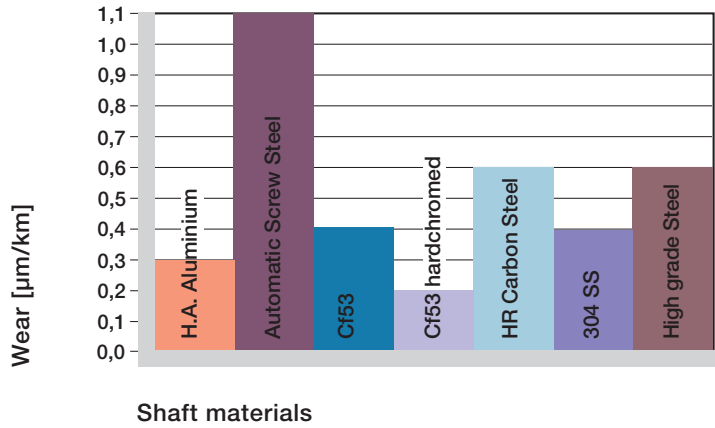

Graph 3.7: Wear of iglidur® J, rotating application with different shaft materials, p = 0.75 MPa, v = 0.5 m/s

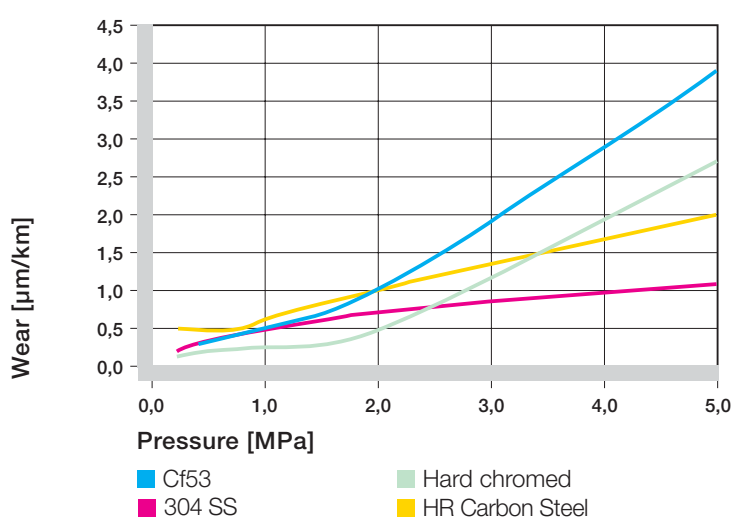

Graph 3.8: Wear of iglidur® J, rotating application with different shaft materials versus pressure

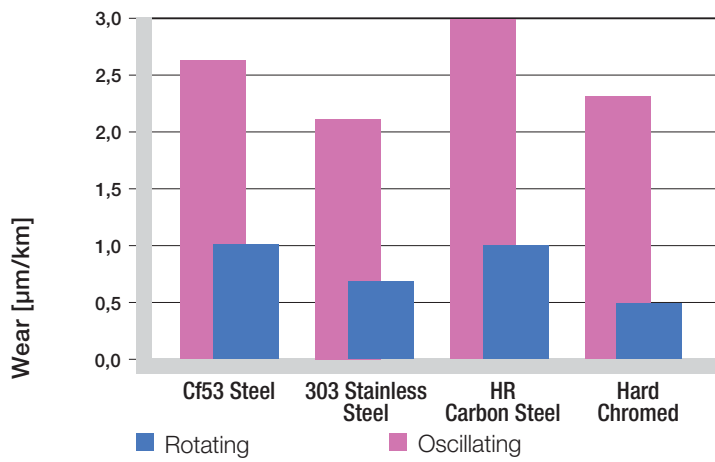

Graph 3.9: Wear for oscillating and rotating applications with different shaft materials under constant pressure, p = 2 MPa

Installation Tolerances

iglidur® J plain bearings are meant to be oversized before pressfit. The bearings are designed for pressfit into a housing machined to a H7 tolerance. After being assembled into a nominal size housing, the inner diameter adjusts to meet our specified tolerances. Please adhere to the catalogue specifications for housing bores and recommended shaft sizes. This will help to ensure optimal performance of iglidur® plain bearings.

► Testing Methods, page 1.32/1.33

Chemical Resistance

iglidur® J plain bearings are resistant to diluted alkaline and very weak acids, as well as fuels and all types of lubricants. The low moisture absorption also permits use in wet or damp environments. Plain bearings made of iglidur® J are resistant to common cleaning agents used in the food industry. The moisture absorption of iglidur® J plain bearings is 0.3% in standard atmosphere. The saturation limit in water is 1.3%. These values are so low that design changes due to absorption are only necessary in extreme cases.

☑ Graph 3.10
► Chemical Table, pages 70.1

iglidur® J | Technical data

Radiation Resistance

Plain bearings made from iglidur® J are resistant to radiation up to an intensity of 300 Gy.

UV Resistance

iglidur® J plain bearings become discoloured under UV radiation. However, hardness, compressive strength and the wear resistance of the material do not change.

Vacuum

When used in a vacuum environment, the iglidur® J plain bearings release moisture as a vapour. Therefore, only dehumidified bearings are suitable in a vacuum environment.

Electrical Properties

iglidur® J plain bearings are electrically insulating.

Diameter d1 [mm]	Shaft h9 [mm]	iglidur®J E10 [mm]
up to 3	0 - 0,025	+0,014 + 0,054
> 3 to 6	0 - 0,030	+0,020 + 0,068
> 6 to 10	0 - 0,036	+0,025 + 0,083
> 10 to 18	0 - 0,043	+0,032 + 0,102
> 18 to 30	0 - 0,052	+0,040 + 0,124
> 30 to 50	0 - 0,062	+0,050 + 0,150
> 50 to 80	0 - 0,074	+0,060 + 0,180

Table 3.5: Essential tolerances for iglidur® J plain bearings according to ISO 3547-1 after pressfit

Medium	Resistance
Alcohol	+
Hydrocarbons	+
Greases, oils without additives	+
Fuels	+
Diluted acids	0 to -
Strong acids	-
Diluted alkalines	+
Strong alkalines	+ to 0

Table 3.6: Chemical resistance of iglidur® J – detailed list, page 70.1

+ resistant 0 conditionally resistant - not resistant
All data given at room temperature [20°C]

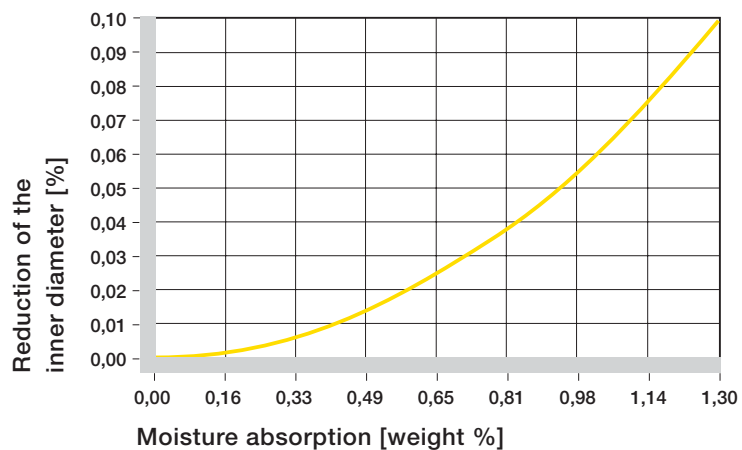

Graph 3.10: Effect of moisture absorption on iglidur® J plain bearings

iglidur® J	
Specific volume resistance	> 10 ¹³ Ωcm
Surface resistance	> 10 ¹² Ω

Table 3.7: Electrical properties of iglidur® J

iglidur® J

Phone +44 (0) 1604 - 67 72 40
Fax +44 (0) 1604 - 67 72 45



iglidur® J | Sleeve Bearing | mm

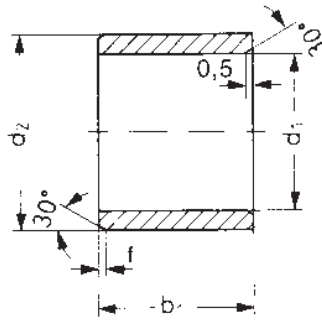

Data in mm

Structure – part no.
J S M-0203-07

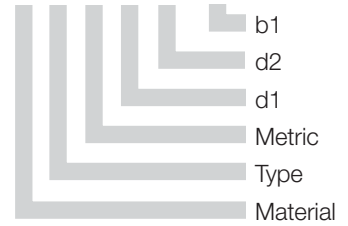

Chamfer in relation to the d1

d1 [mm]:	Ø 1-6	Ø 6-12	Ø 12-30	Ø > 30
f [mm]:	0,3	0,5	0,8	1,2

Dimensions according to ISO 3547-1
and special dimensions

Part Number	d1	d1 Tolerance*	d2	b1 h13	Part Number	d1	d1 Tolerance*	d2	b1 h13
JSM-0203-07	2,0	+0,020 +0,080	3,5	7,0	JSM-0810-16	8,0	+0,025 +0,083	10,0	16,0
JSM-0205-02	2,0	+0,020 +0,080	5,0	2,5	JSM-0812-10	8,0	+0,040 +0,130	12,0	10,0
JSM-0206-02	2,5	+0,020 +0,080	6,0	2,5	JSM-0812-12	8,0	+0,040 +0,130	12,0	12,0
JSM-0304-05	3,0	+0,020 +0,068	4,5	5,0	JSM-1012-05	10,0	+0,025 +0,083	12,0	5,0
JSM-0304-09	3,0	+0,020 +0,068	4,5	9,0	JSM-1012-06	10,0	+0,025 +0,083	12,0	6,0
JSM-0305-04	3,0	+0,020 +0,080	5,0	4,0	JSM-1012-08	10,0	+0,025 +0,083	12,0	8,0
JSM-0308-04	3,0	+0,020 +0,080	8,0	4,0	JSM-1012-10	10,0	+0,025 +0,083	12,0	10,0
JSM-0405-04	4,0	+0,020 +0,068	5,5	4,0	JSM-1012-11	10,0	+0,025 +0,083	12,0	11,0
JSM-0405-08	4,0	+0,020 +0,068	5,5	8,0	JSM-1012-12	10,0	+0,025 +0,083	12,0	12,0
JSM-0507-046	5,0	+0,020 +0,068	7,0	4,6	JSM-1012-15	10,0	+0,025 +0,083	12,0	15,0
JSM-0507-05	5,0	+0,020 +0,068	7,0	5,0	JSM-1012-20	10,0	+0,025 +0,083	12,0	20,0
JSM-0507-10	5,0	+0,020 +0,068	7,0	10,0	JSM-1014-10	10,0	+0,040 +0,130	14,0	10,0
JSM-0507-15	5,0	+0,020 +0,080	7,0	15,0	JSM-1014-16	10,0	+0,040 +0,130	14,0	16,0
JSM-0607-08	6,0	+0,010 +0,058	7,0	8,0	JSM-1214-06	12,0	+0,032 +0,102	14,0	6,0
JSM-0607-12,5	6,0	+0,010 +0,058	7,0	12,5	JSM-1214-08	12,0	+0,032 +0,102	14,0	8,0
JSM-0607-14	6,0	+0,010 +0,058	7,0	14,0	JSM-1214-09	12,0	+0,032 +0,102	14,0	9,0
JSM-0608-043	6,0	+0,020 +0,068	8,0	4,3	JSM-1214-10	12,0	+0,032 +0,102	14,0	10,0
JSM-0608-06	6,0	+0,020 +0,068	8,0	6,0	JSM-1214-15	12,0	+0,032 +0,102	14,0	15,0
JSM-0608-10	6,0	+0,020 +0,068	8,0	10,0	JSM-1216-12	12,0	+0,050 +0,160	16,0	12,0
JSM-0609-06	6,0	+0,030 +0,105	9,0	6,0	JSM-1216-17	12,0	+0,050 +0,160	16,0	17,0
JSM-0610-10	6,0	+0,030 +0,105	10,0	10,0	JSM-1416-05	14,0	+0,032 +0,102	16,0	5,0
JSM-0709-09	7,0	+0,025 +0,083	9,0	9,0	JSM-1416-08	14,0	+0,032 +0,102	16,0	8,0
JSM-0810-04	8,0	+0,025 +0,083	10,0	4,0	JSM-1416-10	14,0	+0,032 +0,102	16,0	10,0
JSM-0810-06	8,0	+0,025 +0,083	10,0	6,0	JSM-1416-15	14,0	+0,032 +0,102	16,0	15,0
JSM-0810-08	8,0	+0,025 +0,083	10,0	8,0	JSM-1416-20	14,0	+0,032 +0,102	16,0	20,0
JSM-0810-10	8,0	+0,025 +0,083	10,0	10,0	JSM-1416-25	14,0	+0,032 +0,102	16,0	25,0
JSM-0810-12	8,0	+0,025 +0,083	10,0	12,0	JSM-1418-18	14,0	+0,032 +0,102	18,0	18,0

* after pressfit. Testing methods ► page 1.32/1.33

Phone +44 (0) 16 04 - 67 72 40
Fax +44 (0) 16 04 - 67 72 45

iglus® UK Ltd

Internet www.igus.co.uk
E-mail sales_uk@igus.co.uk

mm

iglidur® J – Type S

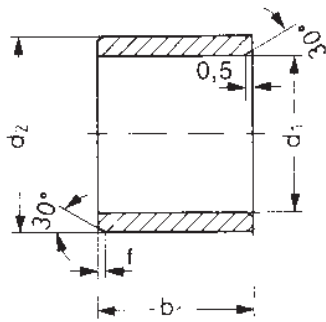

Data in mm

Structure – part no.
J S M-1517-12



Chamfer in relation to the d1

d1 [mm]:	Ø 1-6	Ø 6-12	Ø 12-30	Ø > 30
f [mm]:	0,3	0,5	0,8	1,2

Dimensions according to ISO 3547-1 and special dimensions

Part Number	d1	d1 Tolerance*	d2	b1 h13	Part Number	d1	d1 Tolerance*	d2	b1 h13
JSM-1517-12	15,0	+0,032 +0,102	17,0	12,0	JSM-2532-35	25,0	+0,065 +0,195	32,0	35,0
JSM-1517-20	15,0	+0,032 +0,102	17,0	20,0	JSM-2630-20	26,0	+0,065 +0,195	30,0	20,0
JSM-1618-10	16,0	+0,032 +0,102	18,0	10,0	JSM-3034-20	30,0	+0,040 +0,124	34,0	20,0
JSM-1618-12	16,0	+0,032 +0,102	18,0	12,0	JSM-3034-25	30,0	+0,040 +0,124	34,0	25,0
JSM-1618-15	16,0	+0,032 +0,102	18,0	15,0	JSM-3034-30	30,0	+0,040 +0,124	34,0	30,0
JSM-1618-20	16,0	+0,032 +0,102	18,0	20,0	JSM-3038-40	30,0	+0,065 +0,195	38,0	40,0
JSM-1620-16	16,0	+0,050 +0,160	20,0	16,0	JSM-3236-20	32,0	+0,050 +0,150	36,0	20,0
JSM-1622-16	16,0	+0,050 +0,160	22,0	16,0	JSM-3236-30	32,0	+0,050 +0,150	36,0	30,0
JSM-1622-20	16,0	+0,050 +0,160	22,0	20,0	JSM-3236-40	32,0	+0,050 +0,150	36,0	40,0
JSM-1820-15	18,0	+0,032 +0,102	20,0	15,0	JSM-3539-20	35,0	+0,050 +0,150	39,0	20,0
JSM-1820-20	18,0	+0,032 +0,102	20,0	20,0	JSM-3539-30	35,0	+0,050 +0,150	39,0	30,0
JSM-1922-14	19,0	+0,032 +0,102	22,0	14,0	JSM-3539-40	35,0	+0,050 +0,150	39,0	40,0
JSM-2022-20	20,0	+0,040 +0,124	22,0	20,0	JSM-3640-45	36,0	+0,050 +0,150	40,0	45,0
JSM-2022-30	20,0	+0,040 +0,124	22,0	30,0	JSM-4044-30	40,0	+0,050 +0,150	44,0	30,0
JSM-2023-15	20,0	+0,040 +0,124	23,0	15,0	JSM-4044-35	40,0	+0,050 +0,150	44,0	35,0
JSM-2023-20	20,0	+0,040 +0,124	23,0	20,0	JSM-4044-40	40,0	+0,050 +0,150	44,0	40,0
JSM-2026-06	20,0	+0,065 +0,195	26,0	6,0	JSM-4246-73	42,0	+0,080 +0,240	46,0	73,0
JSM-2026-20	20,0	+0,065 +0,195	26,0	20,0	JSM-5055-30	50,0	+0,050 +0,150	55,0	30,0
JSM-2026-25	20,0	+0,065 +0,195	26,0	25,0	JSM-5055-50	50,0	+0,050 +0,150	55,0	50,0
JSM-2026-30	20,0	+0,065 +0,195	26,0	30,0	JSM-5560-60	55,0	+0,060 +0,180	60,0	60,0
JSM-2427-25	24,0	+0,040 +0,124	27,0	25,0	JSM-6065-60	60,0	+0,060 +0,180	65,0	60,0
JSM-2427-46	24,0	+0,040 +0,124	27,0	46,0	JSM-7580-60	75,0	+0,060 +0,180	80,0	60,0
JSM-2528-12	25,0	+0,040 +0,124	28,0	12,0	JSM-8085-100	80,0	+0,060 +0,180	85,0	100,0
JSM-2528-20	25,0	+0,040 +0,124	28,0	20,0	JSM-100105-100	100,0	+0,072 +0,212	105,0	100,0
JSM-2528-30	25,0	+0,040 +0,124	28,0	30,0					
JSM-2532-25	25,0	+0,065 +0,195	32,0	25,0					
JSM-2532-32	25,0	+0,065 +0,195	32,0	32,0					

* after pressfit. Testing methods ► page 1.32/1.33

iglidur® J – Type S

mm

Phone +44 (0) 1604 - 67 72 40
Fax +44 (0) 1604 - 67 72 45





iglidur® J | Flange Bearing | mm

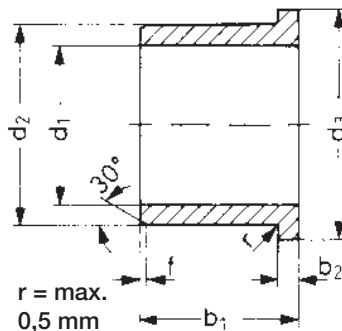

Data in mm

Structure – part no.

J F M-0304-05

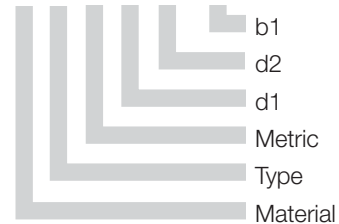

Chamfer in relation to the d1

d1 [mm]:	Ø 1-6	Ø 6-12	Ø 12-30	Ø > 30
f [mm]:	0,3	0,5	0,8	1,2

Dimensions according to ISO 3547-1 and special dimensions

Part Number	d1	d1 Tolerance*	d2	d3 d13	b1 h13	b2 -0,14
JFM-0304-05	3,0	+0,014 +0,054	4,5	7,5	5,0	0,75
JFM-0306-10	3,0	+0,020 +0,080	6,0	9,0	10,0	1,5
JFM-0405-03	4,0	+0,020 +0,068	5,5	9,5	3,0	0,75
JFM-0405-06	4,0	+0,020 +0,068	5,5	9,5	6,0	0,75
JFM-0507-05	5,0	+0,020 +0,068	7,0	11,0	5,0	1,0
JFM-0608-04	6,0	+0,020 +0,068	8,0	12,0	4,0	1,0
JFM-0608-06	6,0	+0,020 +0,068	8,0	12,0	6,0	1,0
JFM-0608-08	6,0	+0,020 +0,068	8,0	12,0	8,0	1,0
JFM-0608-10	6,0	+0,020 +0,068	8,0	12,0	10,0	1,0
JFM-0610-10	6,0	+0,030 +0,105	10,0	14,0	10,0	2,0
JFM-0810-038	8,0	+0,025 +0,083	10,0	15,0	3,8	1,0
JFM-0810-05	8,0	+0,025 +0,083	10,0	15,0	5,0	1,0
JFM-0810-06	8,0	+0,025 +0,083	10,0	15,0	6,0	1,0
JFM-0810-07	8,0	+0,025 +0,083	10,0	15,0	7,0	1,0
JFM-0810-08	8,0	+0,025 +0,083	10,0	15,0	8,0	1,0
JFM-0810-10	8,0	+0,025 +0,083	10,0	15,0	10,0	1,0
JFM-0810125-10	8,0	+0,025 +0,083	10,0	12,5	10,0	1,0
JFM-081014-10	8,0	+0,025 +0,083	10,0	14,0	10,0	1,0
JFM-081016-11	8,0	+0,025 +0,083	10,0	16,0	11,0	1,0
JFM-0812-06	8,0	+0,025 +0,083	12,0	16,0	6,0	2,0
JFM-1012-05	10,0	+0,025 +0,083	12,0	18,0	5,0	1,0
JFM-1012-09	10,0	+0,025 +0,083	12,0	18,0	9,0	1,0
JFM-1012-10	10,0	+0,025 +0,083	12,0	18,0	10,0	1,0
JFM-1012-12	10,0	+0,025 +0,083	12,0	18,0	12,0	1,0
JFM-1012-15	10,0	+0,025 +0,083	12,0	18,0	15,0	1,0
JFM-1012-18	10,0	+0,025 +0,083	12,0	18,0	18,0	1,0
JFM-101215-035	10,0	+0,025 +0,083	12,0	15,0	3,5	1,0
JFM-1113-05	11,0	+0,025 +0,083	13,0	18,0	5,0	1,0
JFM-1214-05	12,0	+0,032 +0,102	14,0	20,0	5,0	1,0
JFM-1214-07	12,0	+0,032 +0,102	14,0	20,0	7,0	1,0
JFM-1214-09	12,0	+0,032 +0,102	14,0	20,0	9,0	1,0
JFM-1214-12	12,0	+0,032 +0,102	14,0	20,0	12,0	1,0
JFM-1214-15	12,0	+0,032 +0,102	14,0	20,0	15,0	1,0
JFM-121418-045	12,0	+0,032 +0,102	14,0	18,0	4,5	1,0
JFM-121418-10	12,0	+0,032 +0,102	14,0	18,0	10,0	1,0
JFM-1218-08	12,0	+0,050 +0,160	18,0	24,0	8,0	3,0
JFM-1218-12	12,0	+0,050 +0,160	18,0	24,0	12,0	3,0
JFM-1218-20	12,0	+0,050 +0,160	18,0	22,0	20,0	3,0

* after pressfit. Testing methods ► page 1.32/1.33

Phone +44 (0) 16 04 - 67 72 40
Fax +44 (0) 16 04 - 67 72 45

iglus® UK Ltd

Internet www.igus.co.uk
E-mail sales_uk@igus.co.uk

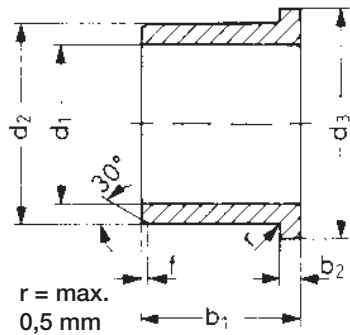

Data in mm

Structure – part no.
J F M-1416-03



Chamfer in relation to the d1

d1 [mm]:	Ø 1-6	Ø 6-12	Ø 12-30	Ø > 30
f [mm]:	0,3	0,5	0,8	1,2

Dimensions according to ISO 3547-1
and special dimensions

Part Number	d1	d1 Tolerance*	d2	d3		b2
				d13	h13	
JFM-1416-03	14,0	+0,032 +0,102	16,0	22,0	3,0	1,0
JFM-1416-10	14,0	+0,032 +0,102	16,0	22,0	10,0	1,0
JFM-1416-12	14,0	+0,032 +0,102	16,0	22,0	12,0	1,0
JFM-1416-17	14,0	+0,032 +0,102	16,0	22,0	17,0	1,0
JFM-141822-20	14,0	+0,032 +0,102	18,0	22,0	20,0	2,0
JFM-1517-09	15,0	+0,032 +0,102	17,0	23,0	9,0	1,0
JFM-1517-12	15,0	+0,032 +0,102	17,0	23,0	12,0	1,0
JFM-1517-17	15,0	+0,032 +0,102	17,0	23,0	17,0	1,0
JFM-1521-20	15,0	+0,050 +0,160	21,0	27,0	20,0	3,0
JFM-1618-17	16,0	+0,032 +0,102	18,0	24,0	17,0	1,0
JFM-1622-12	16,0	+0,050 +0,160	22,0	28,0	12,0	3,0
JFM-1622-15	16,0	+0,050 +0,160	22,0	28,0	15,0	3,0
JFM-1719-09	17,0	+0,032 +0,102	19,0	25,0	9,0	1,0
JFM-1719-21	17,0	+0,032 +0,102	19,0	25,0	21,0	1,0
JFM-1820-04	18,0	+0,032 +0,102	20,0	26,0	4,0	1,0
JFM-1820-12	18,0	+0,032 +0,102	20,0	26,0	12,0	1,0
JFM-1820-22	18,0	+0,032 +0,102	20,0	26,0	22,0	1,0
JFM-1922-36	19,0	+0,032 +0,102	22,0	26,0	36,0	1,0
JFM-2023-11	20,0	+0,040 +0,124	23,0	30,0	11,5	1,5
JFM-2023-15.5	20,0	+0,065 +0,195	23,0	30,0	15,5	1,5
JFM-2023-21	20,0	+0,040 +0,124	23,0	30,0	21,5	1,5
JFM-2026-15	20,0	+0,065 +0,195	26,0	32,0	15,0	3,0
JFM-202530-15	20,0	+0,065 +0,195	25,0	30,0	15,0	2,0
JFM-2026-20	20,0	+0,065 +0,195	26,0	32,0	20,0	3,0
JFM-2026-25	20,0	+0,065 +0,195	26,0	32,0	25,0	3,0
JFM-222532-08	22,0	+0,040 +0,124	25,0	32,0	8,0	1,5
JFM-2430-30	24,0	+0,040 +0,124	30,0	36,0	30,0	3,0
JFM-2528-06	25,0	+0,040 +0,124	28,0	35,0	6,0	1,5
JFM-2528-14.5	25,0	+0,040 +0,124	28,0	35,0	14,5	1,5
JFM-2528-21	25,0	+0,040 +0,124	28,0	35,0	21,5	1,5
JFM-252839-075	25,0	+0,040 +0,124	28,0	39,0	7,5	1,5
JFM-2532-20	25,0	+0,065 +0,195	32,0	38,0	20,0	4,0
JFM-2532-25	25,0	+0,065 +0,195	32,0	38,0	25,0	4,0
JFM-283235-07	28,0	+0,065 +0,195	32,0	35,0	7,0	2,0
JFM-3034-20	30,0	+0,040 +0,124	34,0	42,0	20,0	2,0
JFM-3034-26	30,0	+0,040 +0,124	34,0	42,0	26,0	2,0
JFM-3038-30	30,0	+0,065 +0,195	38,0	44,0	30,0	4,0
JFM-3539-12	35,0	+0,050 +0,150	39,0	47,0	12,0	2,0

* after pressfit. Testing methods ► page 1.32/1.33

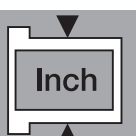



iglidur® J | Flange Bearing | mm

mm

iglidur® J – Type F

Phone +44 (0) 16 04 - 67 72 40

Fax +44 (0) 16 04 - 67 72 45

iglus® UK Ltd

Internet www.igus.co.uk

E-mail sales_uk@igus.co.uk

3.12

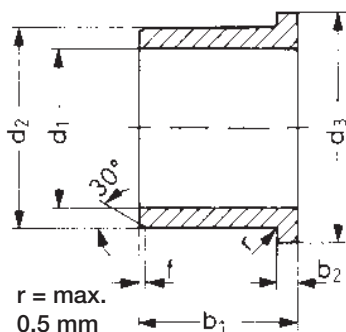

Data in mm

Structure – part no.

J F M-3539-16



Chamfer in relation to the d1

d1 [mm]:	Ø 1-6	Ø 6-12	Ø 12-30	Ø > 30
f [mm]:	0,3	0,5	0,8	1,2

Dimensions according to ISO 3547-1 and special dimensions

Part Number	d1	d1 Tolerance*	d2	d3 d13	b1 h13	b2 -0,14
JFM-3539-16	35,0	+0,050 +0,150	39,0	47,0	16,0	2,0
JFM-3539-26	35,0	+0,050 +0,150	39,0	47,0	26,0	2,0
JFM-4044-20	40,0	+0,050 +0,150	44,0	52,0	20,0	2,0
JFM-4044-30	40,0	+0,050 +0,150	44,0	52,0	30,0	2,0
JFM-4044-40	40,0	+0,050 +0,150	44,0	52,0	40,0	2,0
JFM-4550-20	45,0	+0,050 +0,150	50,0	58,0	20,0	2,0
JFM-4550-50	45,0	+0,050 +0,150	50,0	58,0	50,0	2,0
JFM-5055-50	50,0	+0,050 +0,150	55,0	63,0	50,0	2,0
JFM-5560-50	55,0	+0,060 +0,180	60,0	68,0	50,0	2,0
JFM-6065-50	60,0	+0,060 +0,180	65,0	73,0	50,0	2,5
JFM-7075-50	70,0	+0,060 +0,180	75,0	83,0	50,0	2,0

* after pressfit. Testing methods ► page 1.32/1.33



The advantages of iglidur® J bearings in this packaging application are the high chemical resistance and dry running. Polymer bearings are vibration dampening.

Lifetime calculation, CAD files and much more support ► www.igus.co.uk/en/j

iglidur® J | Thrust Washer | mm

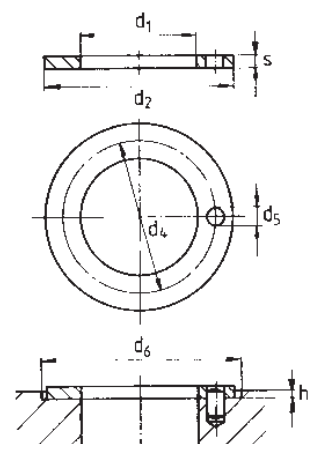

Data in mm
Structure – part no.
J T M-1223-015

- s
- d2
- d1
- Metric
- Type
- Material

Dimensions according to ISO 3547-1 and special dimensions

Part Number	d1	d2	s	d4	d5	h	d6
	0,3	-0,3	-0,05	-0,12 +0,12	+0,375 +0,125	+0,2 0,2	+0,12
JTM-1223-015	12,0	23,0	1,5	18,0	1,5	1,0	23,0
JTM-1224-015	12,0	24,0	1,5	18,0	1,5	1,0	24,0
JTM-2036-015	20,0	36,0	1,5	28,0	3,0	1,0	36,0
JTM-3039-015	30,0	39,0	1,5	**	**	1,0	39,0
JTM-5670-010	56,0	70,0	1,0	**	**	0,7	70,0

** Design without fixing bore

iglidur® J – Type T
mm

Phone +44 (0) 1604 - 67 7240
 Fax +44 (0) 1604 - 67 7245



Order example Type S Type F Type T

Our price breaks are defined by the order quantity.

1– 9	50– 99	500– 999
10–24	100–199	1000–2499
25–49	200–499	2500–4999

For the current prices please visit the iglus®-Homepage www.igus.co.uk

No minimum order quantities, no surcharges.