

Inductive Sensors



Housing Style	Part Number	ID Number	Features	Sensing Range (mm)	Output
8 mm - Embeddable, Miniature Threaded, eurofast® Quick Disconnect 	Bi 2-EG08K-AG41X-H1341	S4562011	Short Barrel	2	2-Wire DC
	Bi 2-EG08K-AG41X-H1341/S1589	S4562090	weldguard®	2	
	Bi 1.5-EG08K-AN6X-H1341	S4669150	Short Barrel	1.5	3-Wire DC NPN
	Bi 2-EG08K-AN6X-H1341	S4669560	Short Barrel	2	
	Bi 1.5-EG08K-AP6X-H1341	S4669050	Short Barrel	1.5	3-Wire DC PNP
	Bi 2-EG08K-AP6X-H1341	S4669460	Short Barrel	2	
	Bi 2-EG08K-AP6X-H1341/S1589	S4669486	weldguard	2	
	Bi 1.5-EG08K-Y1-H1341	S1003620	Short Barrel	1.5	2-Wire DC NAMUR
	Bi 1.5-EG08K-Y1X-H1341	S1003640	Short Barrel	1.5	
	8 mm - Embeddable, Miniature Threaded, eurofast Quick Disconnect 	Bi 2-EG08-AG41X-H1341	S4562001	Ext. Range	2
Bi 2-EG08-AG41X-H1341/S1589		S4562095	weldguard	2	
Bi 1.5-EG08-AD6X-H1341		S4600203		1.5	
Bi 1.5-EG08-AN6X-H1341		S4602360		1.5	3-Wire DC NPN
Bi 1.5-EG08WD-AN6X-H1341		S4602211	Washdown	1.5	
Bi 1.5-EG08-AN7X-H1341		S4602361	TTL Compatible	1.5	
Bi 1.5U-EG08-AN6X-H1341		S4600550	Uprox	1.5	
Bi 2-EG08-AN6X-H1341		S4602160	Ext. Range	2	
Bi 2-EG08-AN6X-H1341/S1589		S4602182	weldguard	2	
Bi 2U-EG08-AN6X-H1341		S4602037	Uprox	2	
Bi 1.5U-EGT08-AN6X-H1341		S4600558	Uprox	1.5	
Bi 1.5-EG08-AP6X-H1341		S4602260		1.5	3-Wire DC PNP
Bi 1.5-EG08WD-AP6X-H1341		S4602210	Washdown	1.5	
Bi 1.5U-EG08-AP6X-H1341		S4600540	Uprox	1.5	
Bi 2-EG08-AP6X-H1341		S4602060	Ext. Range	2	
Bi 2-EG08-AP6X-H1341/S1589		S4602086	weldguard	2	
Bi 2U-EG08-AP6X-H1341		S4602034	Uprox	2	
Bi 1.5U-EG08-AP6X-H1341/S1589		S4600540-1	Uprox/weldguard	1.5	
Bi 1.5U-EGT08-AP6X-H1341		S4600555	Uprox	1.5	
Bi 2-EG08-VN6X-H1341		S4602521	Comp. Outputs	2	4-Wire DC NPN
Bi 2-EG08-VP6X-H1341		S4602522	Comp. Outputs	2	4-Wire DC PNP
Bi 1.5-EG08-Y1-H1341		S1003502		1.5	2-Wire DC NAMUR



Voltage	Switching Freq. (Hz)	Operating Current (mA)	Operating Temp. (°C)	Protection	Housing	Face	Power LED	Output LED	Mating Cordset	Wiring Diagram #	Wiring Diagrams
10-65 VDC	1000	≤100	-25 to +70	IP 67	SS	PA 12	N/A	YE	RK 4T-*	1	Diagram 1
	1000	≤100	-25 to +70	IP 67	SS	WG	N/A	YE	RK 4T-*	1	
10-30 VDC	3000	≤150	-25 to +70	IP 67	SS	PA 12	N/A	YE	RK 4T-*	3	
	3000	≤150	-25 to +70	IP 67	SS	PA 12	N/A	YE	RK 4T-*	3	
10-30 VDC	3000	≤150	-25 to +70	IP 67	SS	PA 12	N/A	YE	RK 4T-*	4	Diagram 2
	3000	≤150	-25 to +70	IP 67	SS	PA 12	N/A	YE	RK 4T-*	4	
	3000	≤150	-25 to +70	IP 67	SS	WG	N/A	YE	RK 4T-*	4	
5-30 VDC	5000	Remote	-25 to +70	IP 67	SS	PA 12	N/A	N/A	RK 4.21T-*	5	Diagram 3
	5000	Remote	-25 to +70	IP 67	SS	PA 12	N/A	YE	RK 4.21T-*	5	
10-65 VDC	1000	≤100	-25 to +70	IP 67	SS	PA 12	N/A	YE	RK 4T-*	1	
	1000	≤100	-25 to +70	IP 67	SS	WG	N/A	YE	RK 4T-*	1	
	1000	≤100	-25 to +70	IP 67	SS	PA 12	N/A	YE	RK 4.2T-*	2	
10-30 VDC	3000	≤150	-25 to +70	IP 67	SS	PA 12	N/A	YE	RK 4T-*	3	Diagram 4
	3000	≤150	-10 to +85	IP 68, 69K	SS	PA 12	N/A	YE	RK 4T-*	3	
	2000	≤150	-25 to +70	IP 68	SS	PA 12	N/A	YE	RK 4T-*	3	
	2000	≤150	-30 to +85	IP 67	SS	PA 12	N/A	YE	RK 4T-*	3	
	3000	≤150	-25 to +70	IP 67	SS	PA 12	N/A	YE	RK 4T-*	3	
	3000	≤150	-25 to +70	IP 67	SS	WG	N/A	YE	RKG 4T-*	3	
	1000	≤150	-35 to +85	IP 68	SS	PA 12	N/A	YE	RK 4T-*	3	
3000	≤150	-30 to +85	IP 67	TC	TC	N/A	YE	RK 4T-*	3		
10-30 VDC	3000	≤150	-25 to +70	IP 67	SS	PA 12	N/A	YE	RK 4T-*	4	Diagram 5
	3000	≤150	-10 to +85	IP 68, 69K	SS	PA 12	N/A	YE	RK 4T-*	4	
	2000	≤150	-30 to +85	IP 68	SS	PA 12	N/A	YE	RK 4T-*	4	
	3000	≤150	-25 to +70	IP 67	SS	PA 12	N/A	YE	RK 4T-*	4	
	3000	≤150	-25 to +70	IP 67	SS	WG	N/A	YE	RKG 4T-2	4	
	1000	≤150	-35 to +85	IP 68	SS	PA 12	N/A	YE	RK 4T-*	4	
	2000	≤150	-30 to +85	IP 67	SS	WG	N/A	YE	RK 4T-*	4	
	2000	≤150	-30 to +85	IP 67	TC	TC	N/A	YE	RK 4T-*	4	
10-30 VDC	3000	≤200	-25 to +70	IP 67	SS	PA 12	N/A	YE	RK 4.4T-*	6	Diagram 6
10-30 VDC	3000	≤200	-25 to +70	IP 67	SS	PA 12	N/A	YE	RK 4.4T-*	7	
5-30 VDC	5000	Remote	-25 to +70	IP 67	SS	PA 12	N/A	N/A	RK 4.21T-*	5	Diagram 7

Barrels

* Length in meters.

WIRING DIAGRAM

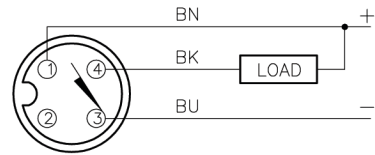

OUTPUT: AN6X

SHORT-CIRCUIT AND OVERLOAD PROTECTED

LOCKNUT LN-SS08

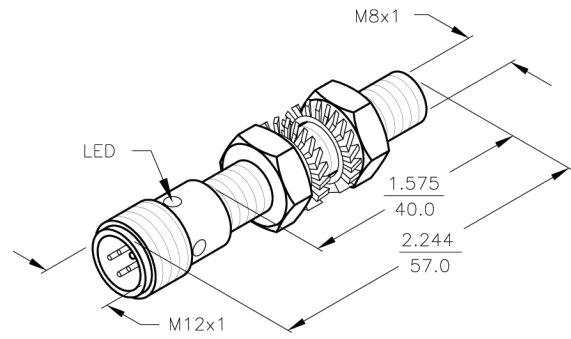
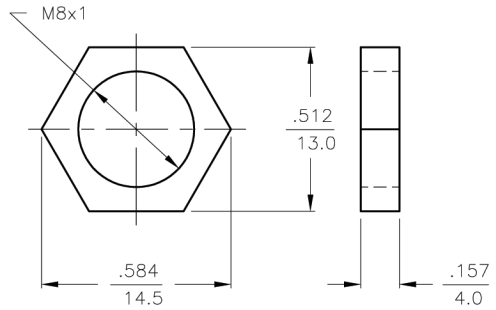

SPECIFICATIONS

OPERATING VOLTAGE	10-30 VDC
RIPPLE	≤ 10%
DIFFERENTIAL TRAVEL (HYSTERESIS)	1-15% (5% TYPICAL)
VOLTAGE DROP ACROSS CONDUCTING SENSOR	≤ 1.8 V at 150 mA
OUTPUT FUNCTION	NORMALLY OPEN 3-WIRE DC SELF-CONTAINED
TTL COMPATIBLE	NO
SHORT-CIRCUIT PROTECTED	YES
TRIGGER CURRENT FOR OVERLOAD PROTECTION	≥ 170 mA
CONTINUOUS LOAD CURRENT	≤ 150 mA
OFF-STATE (LEAKAGE) CURRENT	< 100µ A
NO-LOAD CURRENT	1.0-9.5 mA
TIME DELAY BEFORE AVAILABILITY	≤ 8 ms
POWER-ON EFFECT	Per IEC 947-5-2
REVERSE POLARITY PROTECTION	INCORPORATED
WIRE-BREAK PROTECTION	INCORPORATED
PROTECTION AGAINST TRANSIENTS	EN 60947-5-2
OPERATING TEMPERATURE	-25°C to +70°C (-13°F to +158°F)
ENCLOSURE	MEETS NEMA 1, 3, 4, 6, 13 AND IEC IP67
SHOCK	30 g, 11 ms
VIBRATION	55 Hz, 1 mm AMPLITUDE (IN ALL 3 PLANES)
LED FUNCTION	YELLOW: OUTPUT ENERGIZED
RATED OPERATING DISTANCE(Sn)	2 mm = .079" (NOMINAL)
SWITCHING FREQUENCY	3000 Hz
REPEATABILITY	≤ 2% of RATED OPERATING DISTANCE
EMBEDDABLE (SHIELDED)	YES

RELATED DOCUMENTS 1. 2. 3. 4.	3RD ANGLE PROJECTION 	THIS DRAWING IS PROPERTY OF TURCK INC. USE OF THIS DOCUMENT WITHOUT WRITTEN PERMISSION IS PROHIBITED.		TURCK INC High Technology Sensors and Automation Controls	
	MATERIAL STAINLESS STEEL	TOLERANCES UNLESS OTHERWISE SPECIFIED .X ±0.02 .XX ±0.01 .XXX ±0.005 ANGLES ±1° ALL MILLIMETER DIMENSIONS ARE REFERENCE ONLY	DRFT IK DATE 7/10/97	DSGN SCALE NONE	DESCRIPTION Bi2-EG08-AN6X-H1341
FINISH		UNIT OF MEASUREMENT INCH [MILLIMETER]		IDENTIFICATION NO. S4602160	REV B
B UPDATE TO NEW TITLE BLOCK RDS 11/04/02 5504	BY DATE ECO NO.	DO NOT SCALE THIS DRAWING		FILE: S4602160	SHEET 1 OF 1

REV	DESCRIPTION	BY	DATE	ECO NO.
B	UPDATE TO NEW TITLE BLOCK	RDS	11/04/02	5504