



PRODUCT DATASHEET

Flare series

last update 17/2/2015

DETAILS

Product Number	C14613_FLARE-MAXI-T
Family	Flare
Type	Lens
Color	clear
Diameter	43x28.4 mm
Height	15.5 mm
Style	rectang
Optic Material	PMMA
Holder Material	
Fastening	screw, pin
Status	ready
ROHS Compliant	Yes
Date Updated	17/02/2015

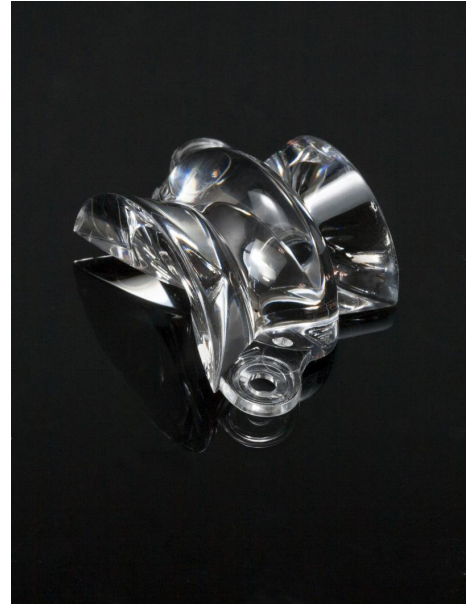

OPTICAL PROPERTIES

LED	Viewing Angle	Light Beam	Efficiency	cd/lm	Connector
LUXEON M	82+21 deg	Asymmetric	93 %	1.300	-

H G F E D C B A

4

4

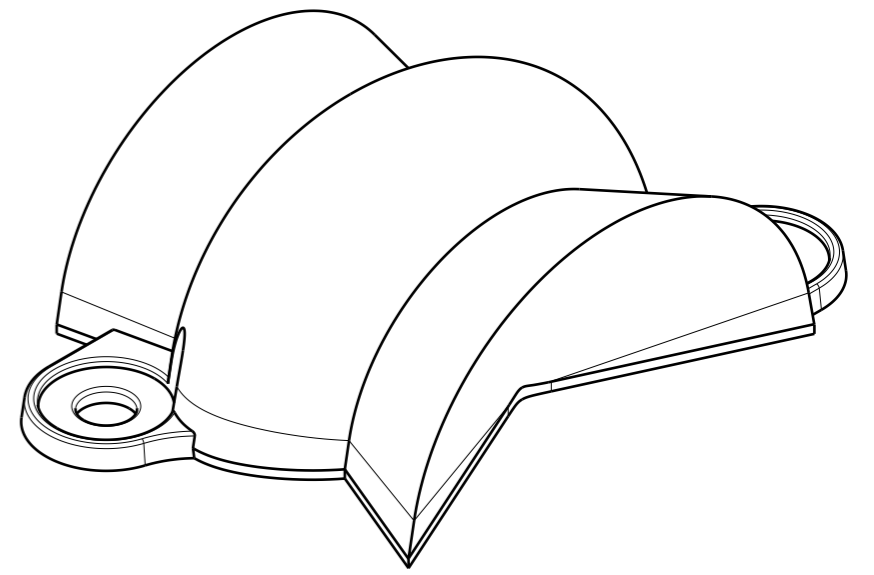
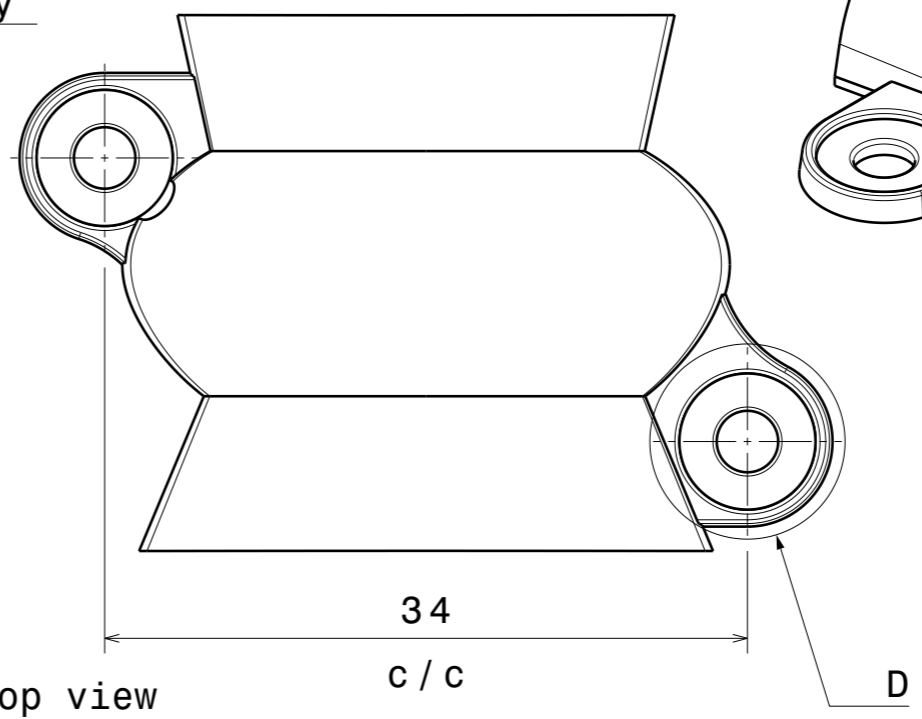
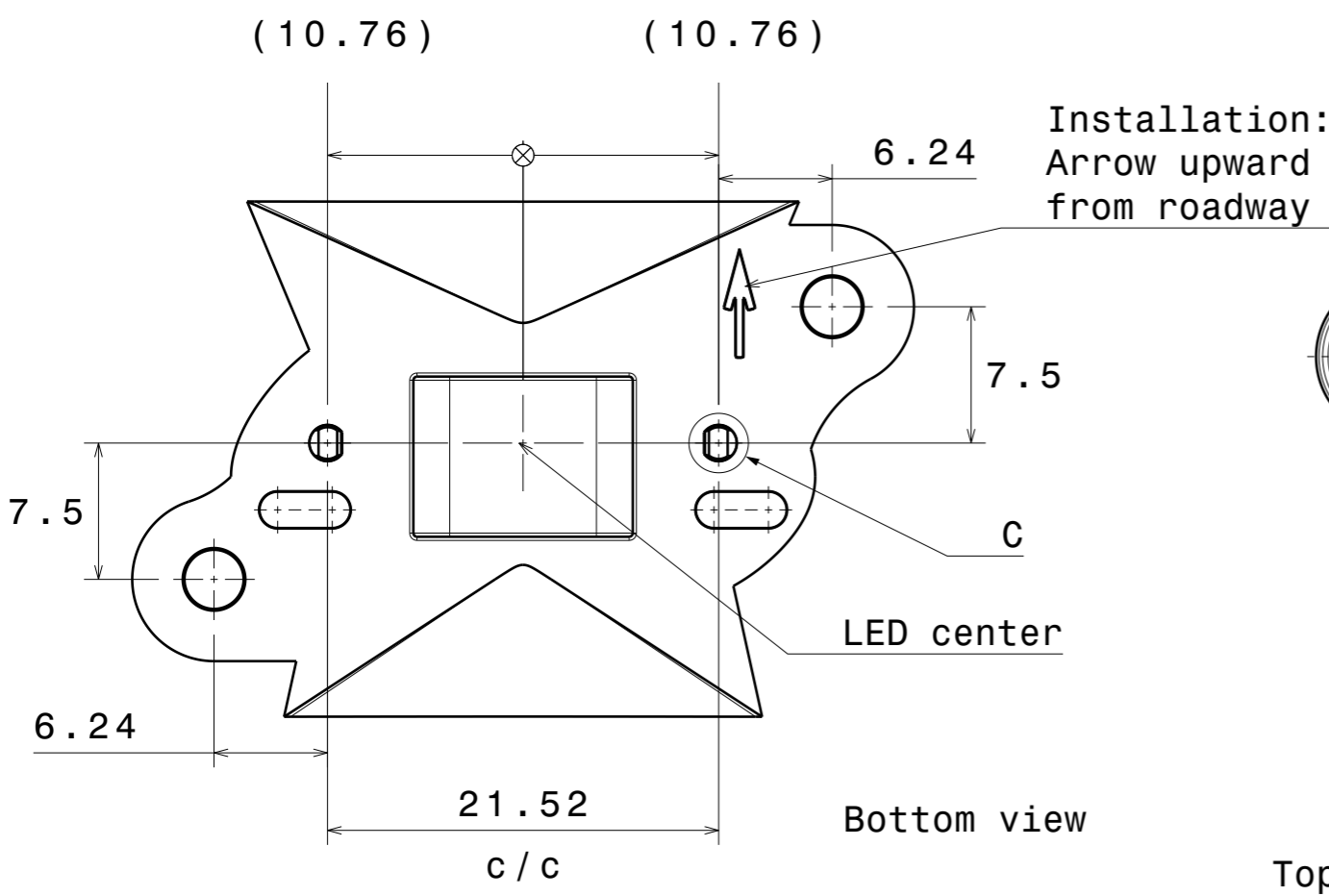

3

3

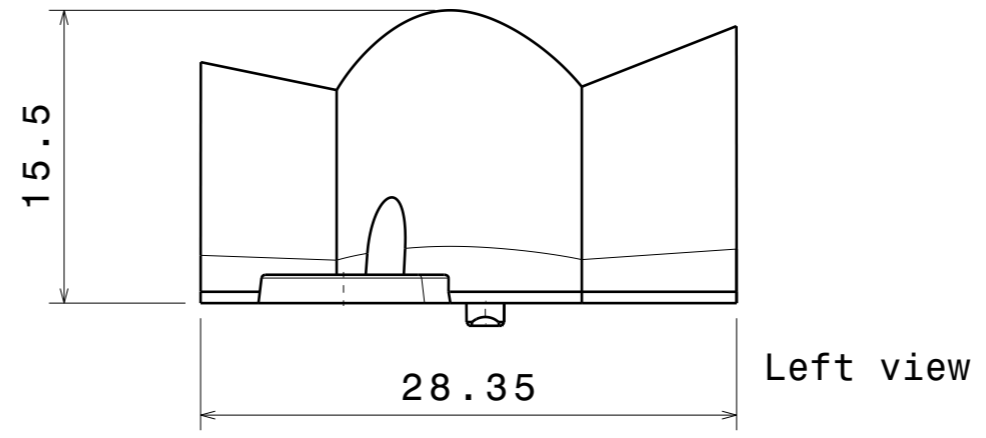
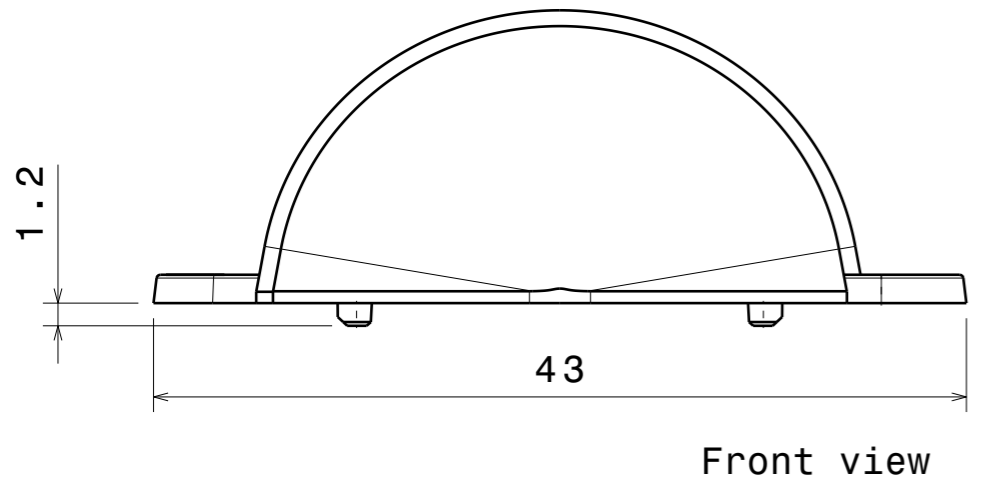

2

2

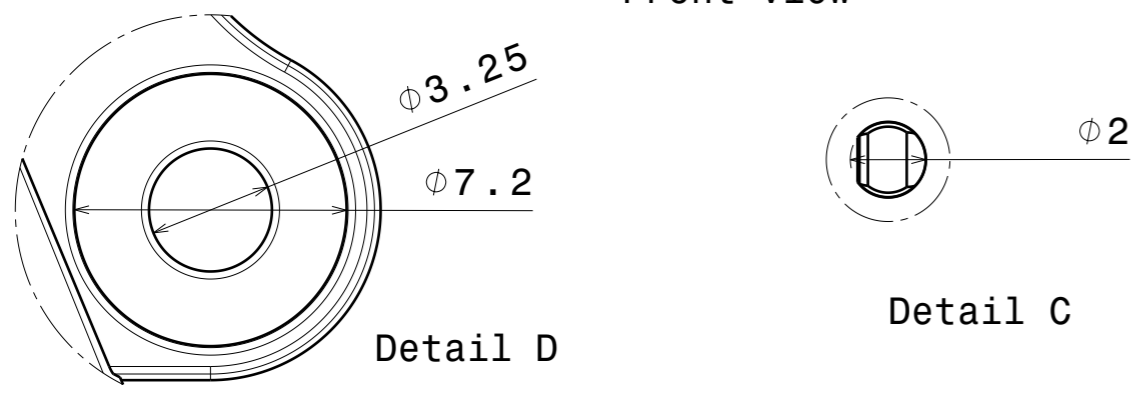

Tolerances if not otherwise shown
According to DIN ISO 2768-1
Linear measures:
up to 30mm class M, otherwise class C
According to DIN ISO 2768-2
Form and position: class L

LEDiL LediL Oy
Salorankatu 10
FIN 24240 SALO
Finland

THIRD ANGLE PROJECTION:

DRAWING TITLE
Datasheet_C14613_FLARE-MAXI-T

This drawing is the property
of LEDiL Oy. It may not be
reproduced, copied or
communicated without a written
agreement with LEDiL Oy.

SIZE	PART NUMBER		
A3	C14613		

SCALE	5:2	WEIGHT	-	SHEET	1/1
-------	-----	--------	---	-------	-----

H G B A

1

1

Luminaire: LEDiL Oy C14613_FLARE-MAXI-T (Luxeon_M)

Lamps: 1 x Philips_Lumileds_Luxeon_M (LXR7_SW40)_340.894lm@250mA_P=2.72366W_I=0.2499A

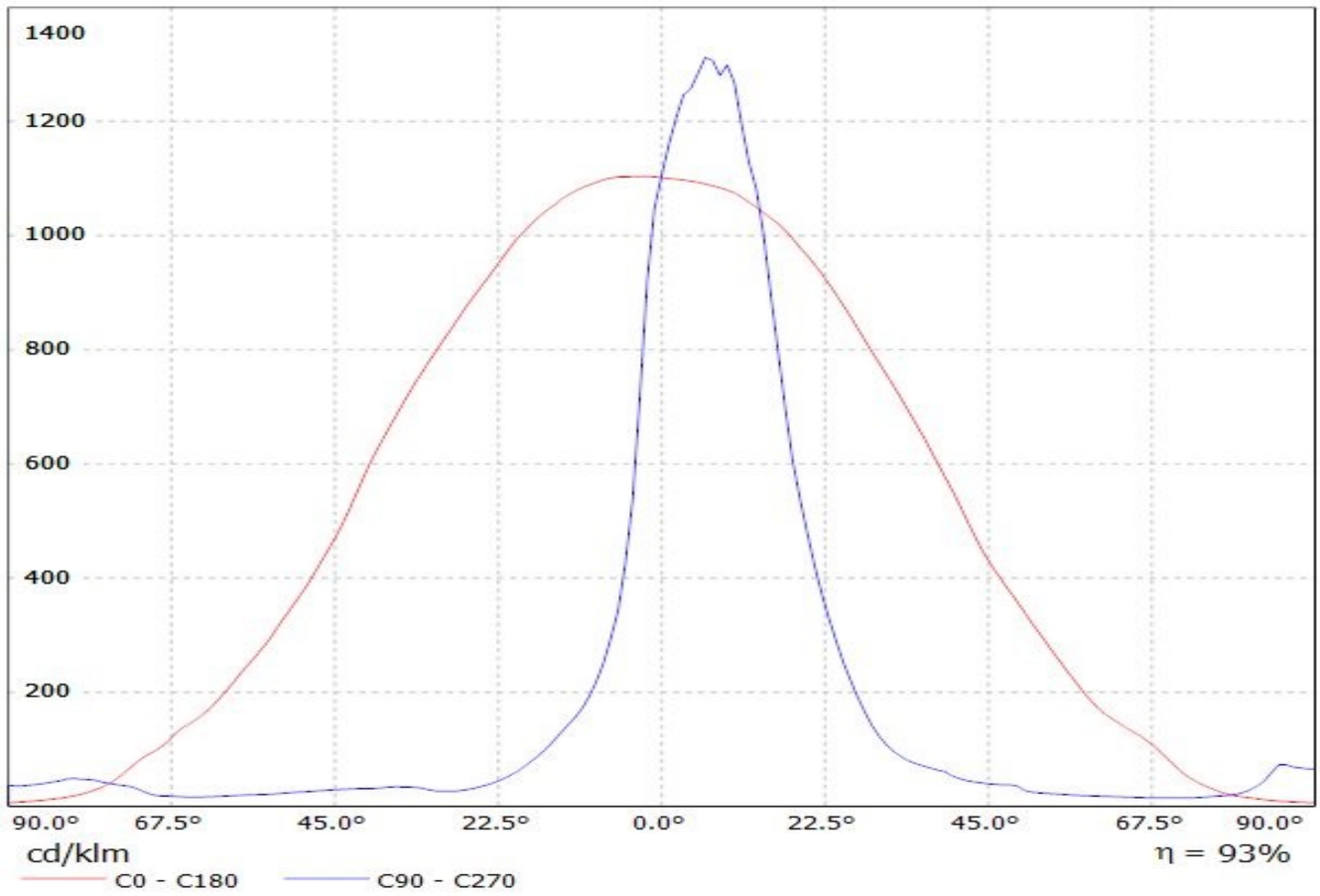

Luminaire: LEDiL Oy C14613_FLARE-MAXI-T_(Luxeon_M)

Lamps: 1 x Philips_Lumileds_Luxeon_M_(LXR7_SW40)_340.894lm@250mA_P=2.72366W_I=0.2499A

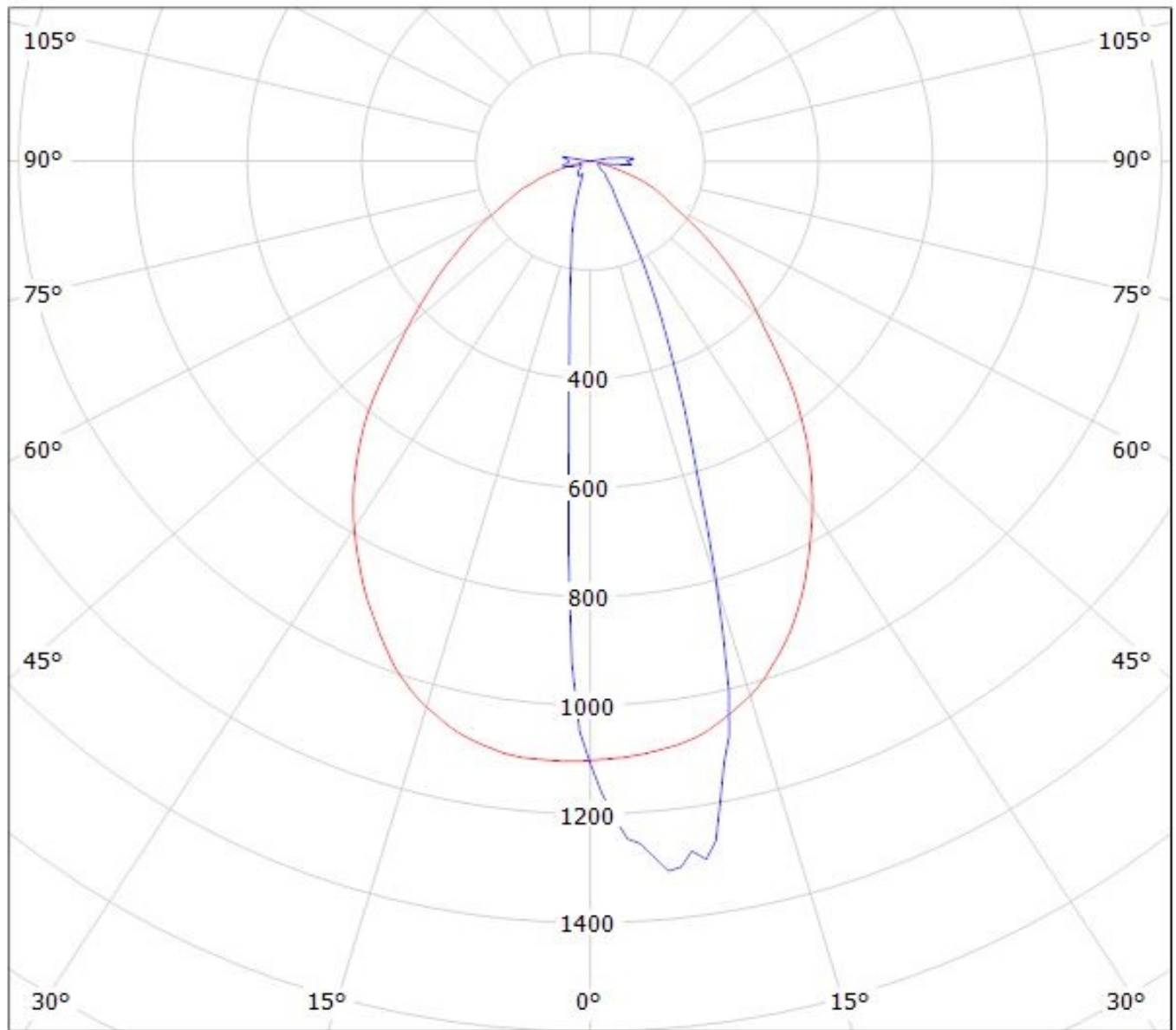

cd/klm

— C0 - C180 — C90 - C270

$\eta = 93\%$

NOTE: The typical divergence will be changed by different color, chip size and chip position tolerance. The typical total divergence is the full angle measured where the luminous intensity is half of the peak value.