

Redundancy unit CP-D RU

Accessory for CP range power supplies (e.g. switch mode power supplies CP-D range)

The CP-D RU provides decoupling of two power supply units and ensures automatic redundant power supply operation for critical applications. The redundancy unit in MDRC design (modular DIN rail components) fits into all domestic installation and distribution panels.

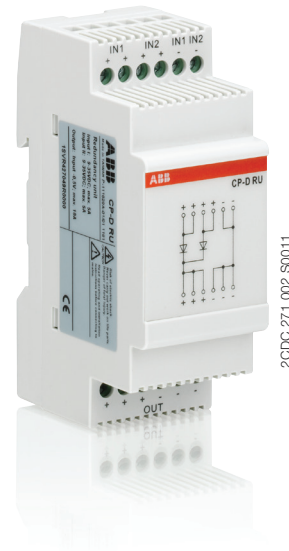

Characteristics

- Decoupling of CP range power supply units
- Two inputs, each up to 5 A per input / channel
- True redundancy or increased power by 100 % decoupling of two parallel connected power supplies.
- Output up to 5 A for true redundancy or up to 10 A for increased power

Marks

CE CE

Order data

Redundancy unit

Type	Rated voltage	Input voltage range	Rated input current	Rated output current	Order code
CP-D RU	24 V DC	9-35 V DC	2 x 5 A	1 x 10 A	1SVR 427 049 R0000

Functions

Terminals

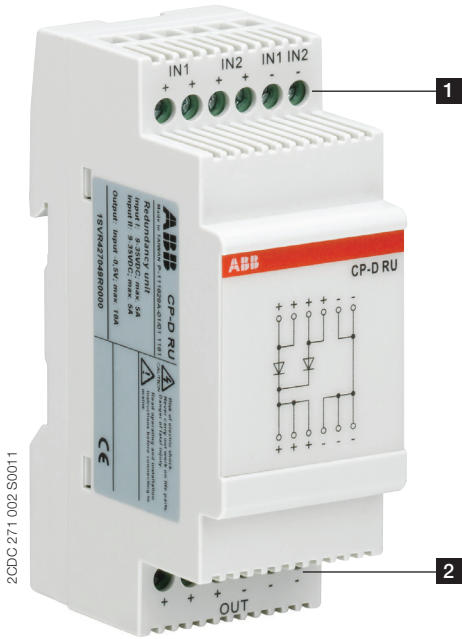

- 1** Input terminals
IN 1+ +, IN 2+ +, IN 1- -, IN 2- -
- 2** Output terminals
OUT + + +, OUT - - -

Application

The redundancy unit CP-D RU provides decoupling of two power supply units (e.g. switch mode power supplies CP-D range). It has two inputs, each up to 5 A per channel and 1 output up to 10 A. It ensures automatic redundant power supply operation for critical applications or enables increased power by two parallel connected power supplies.

Operating modes

Parallel operation, true redundancy

Redundant circuits are suitable to increase the operational reliability and eliminate power supply outages. Events that can cause a power supply failure include: incorrect wiring, blown fuses, or failure of a single devices power supply. If a fault event occurs (called initial fault) in the first power supply circuit, power to all loads is then supplied by the second, redundant power supply. For this reason, both power supplies must be sized to handle the total current requirement of all loads. The CP-D RU ensures that the primary power supply is decoupled from the redundant power supply. It prevents the initial fault from shorting or comprising the redundant supply's output. In this way, uninterrupted supply of power to all loads is guaranteed. When available, the two power supplies should be connected to different input voltage phases, to avoid loss of power caused by a blown fuse on the primary side of the power supplies (see figure below).

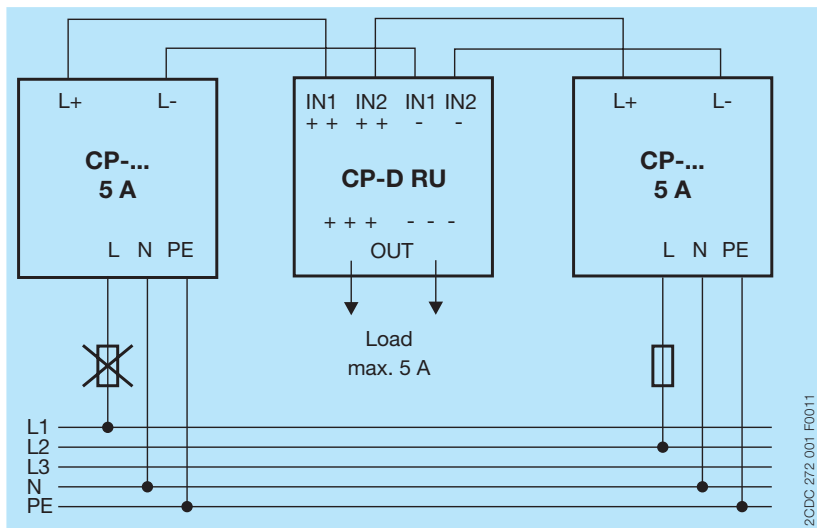

Example of application: Parallel operation, true redundancy

Parallel operation, increased power

If a power supply unit can not handle the current requirement of the most powerful load, it is advisable to increase the power by parallel connected power supplies. For this, the primary and redundant power supplies are decoupled from one another by the CP-D RU unit, as shown in the figure below. Otherwise the loads should be spread among individual devices of each other. The functionality of increased power is to the account of true redundancy.

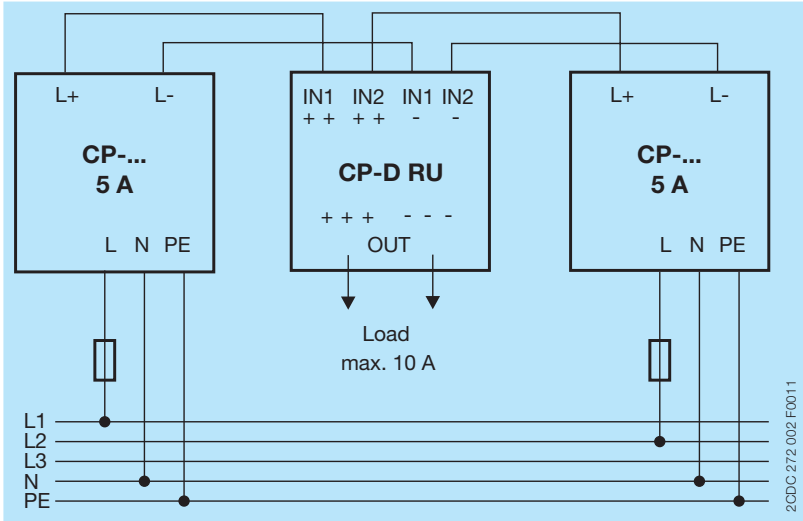

Example of application: Parallel operation, increased power

Parallel operation, increased power and true redundancy

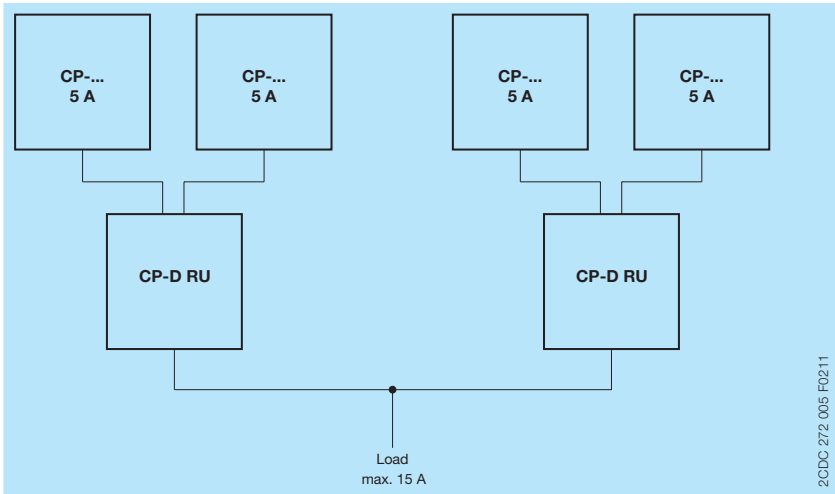

Example of application: Parallel operation, increased power and true redundancy

Operation

Before start of operation the following must be ensured

1. Connect electrical lines according to the specific national regulations for class of protection II.
2. Power supply cables and unit must be sufficiently fused.
3. Rate the lines for the maximum output current and connect them with the correct polarity.
4. In order to ensure sufficient air-cooling the distance to the other devices has to be considered.



Attention!

Improper installation/operation may impair safety and cause operational difficulties or destruction of the unit.

In operation pay attention to



DANGER!

High Current

Risk of electric arcs and electric shocks!

- ▶ Do not modify the installation (primary and secondary side).
- ▶ Intended use.



CAUTION!

Depending on the operation conditions the enclosure can become very hot.

Risk of burns!

Electrical connection

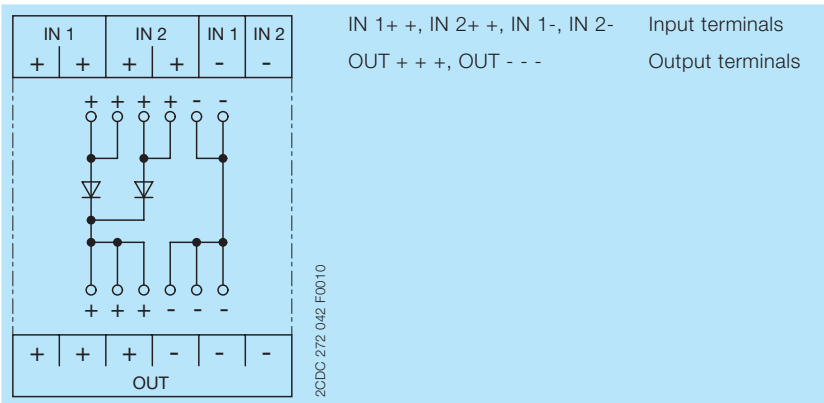

Connection diagram

- Connect the input terminals. For channel 1 input terminals IN 1 + -, for channel 2 input terminals IN 2 + -.
- Rate the lines for the maximum output current or provide a separate fuse protection.
- We recommend to choose the cable cross section as large as possible in order to minimize voltage drops.
- See technical data regarding stripping length of the cable.
- Observe the polarity.

Technical data

Data at $T_a = 25\text{ °C}$ and rated values, unless otherwise indicated.

Input circuits

Supply circuit		IN 1 + + -, IN 2 + + -
Rated input voltage U_{in}		24 V DC
Input voltage range	per channel	9-35 V DC
Rated input current I_{in}	per channel	5 A
Maximum input current	per channel	10 A for 300 s
Transient overvoltage protection		no

Output circuits

		OUT + + +, - - -
Rated output voltage U_{out}		24 V DC
Voltage drop		typ. 0.5 V
Rated output current I_{out}		10 A
Resistance to reverse feed		< 35 V

General data

MTBF		on request
Duty time		100 %
Dimensions (W x H x D)	product dimensions	35 x 91 x 56.5 mm (1.38 x 3.58 x 2.22 in)
	packaging dimensions	134 x 94 x 48 mm (5.28 x 3.70 x 1.89 in)
Weight	net weight	0.075 kg (0.165 lb)
	gross weight	0.130 kg (0.286 lb)
Material of enclosure		plastic
Mounting		DIN rail, snap-on mounting without any tool
Mounting position		horizontal
Minimum distance to other units	horizontal	25 mm (0.98 in)
	vertical	25 mm (0.98 in)

Electrical connection

Wire size	fine-strand with(out) wire end ferrule	0.2-2.5 mm ² (24-14 AWG)
	rigid	0.2-2.5 mm ² (24-12 AWG)
Stripping length		7.0 mm (0.28 in)
Tightening torque		0.67 Nm (6 lb.in)

Environmental data

Ambient temperature ranges	operation	-40...+70 °C
	storage	-40...+85 °C
Relative humidity	RH at 40°C	20-95 %, no condensation
Vibration	IEC/EN 60068-2-6	Mounting by rail: 10-500 Hz, 2 G, along X, Y, Z each axis, 60 min for each axis
Shock	IEC/EN 60068-2-27	15 G, 11 ms, 3 axis, 6 faces, 3 times for each face

Standards

Product standard		IEC/EN 61204-3
Low Voltage Directive		2006/95/EC
EMC Directive		2004/108/EC
RoHS Directive		2002/95/EC

Electromagnetic compatibility

Interference immunity to		EN 55024
electrostatic discharge	IEC/EN 61000-4-2	Level 3, air discharge 8 kV, contact discharge 4 kV
radiated, radio-frequency, electromagnetic field	IEC/EN 61000-4-3	Level 3, 10 V/m
electrical fast transient/burst	IEC/EN 61000-4-4	Level 3, 2 kV / 5 kHz
conducted disturbances, induced by radio-frequency fields	IEC/EN 61000-4-6	Level 3, 10 V
Interference emission		EN 55022
high-frequency radiated	EN 50022	Class B
high-frequency conducted	EN 50022	Class B

Dimensions

in **mm** and *inches*

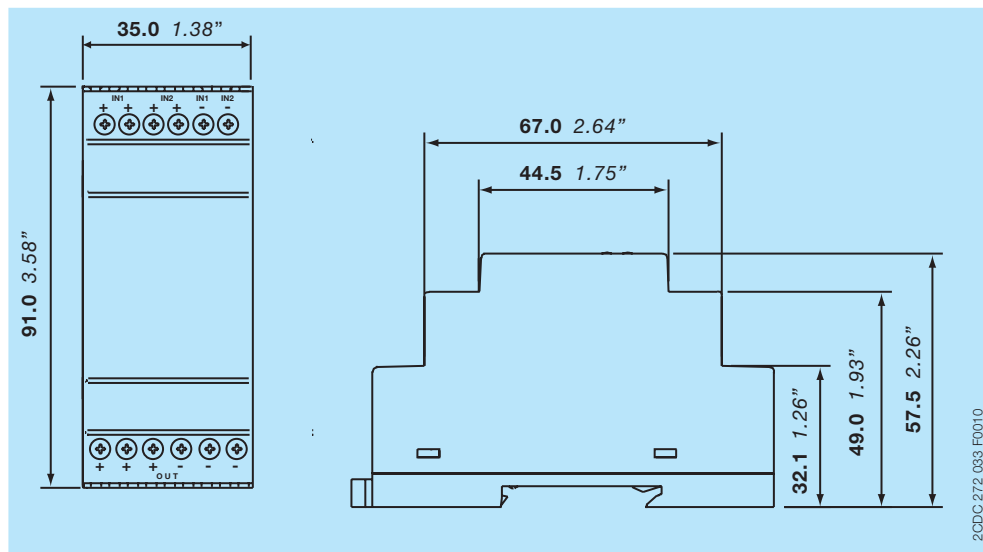

Further Documentation

Document title	Document type	Document number
Electronic Products and Relays	Technical catalogue	2CDC 110 004 C020x
CP-D RU	Instruction sheet	1SVC 427 044 M0000
Power Supply Units	Application manual	2CDC 114 048 M020x
CP-D 12/0.83	Data sheet	2CDC 114 052 D020x
CP-D 12/2.1	Data sheet	2CDC 114 053 D020x
CP-D 24/0.42	Data sheet	2CDC 114 054 D020x
CP-D 24/1.3	Data sheet	2CDC 114 055 D020x
CP-D 24/2.5	Data sheet	2CDC 114 056 D020x
CP-D 24/4.2	Data sheet	2CDC 114 057 D020x

You can find the documentation on the internet at www.abb.com/lowvoltage -> Control Products -> Power Supplies

Contact us

ABB STOTZ-KONTAKT GmbH

P. O. Box 10 16 80
69006 Heidelberg, Germany
Phone: +49 (0) 6221 7 01-0
Fax: +49 (0) 6221 7 01-13 25
E-mail: info.desto@de.abb.com

You can find the address of your
local sales organisation on the
ABB home page
<http://www.abb.com/contacts>
-> Low Voltage Products and Systems

Note:

We reserve the right to make technical changes or modify the contents of this document without prior notice. With regard to purchase orders, the agreed particulars shall prevail. ABB AG does not accept any responsibility whatsoever for potential errors or possible lack of information in this document.

We reserve all rights in this document and in the subject matter and illustrations contained therein. Any reproduction, disclosure to third parties or utilization of its contents – in whole or in parts – is forbidden without prior written consent of ABB AG.

Copyright© 2011 ABB
All rights reserved