



Getting Started with the Atmel ATmega64HVE2 Evaluation Kit

Atmel ATmega64HVE2-EK1

Features

- Demonstrates the functionality of the Atmel® ATmega64HVE2 8-bit AVR® microcontroller in an Intelligent Battery Sensor (IBS) application.
- PC-based Graphical User Interface (GUI) for easy control and readout of voltage, current, and temperature measurement values.
- Includes a reference design for Atmel ATmega64HVE2 and sample software for readout of measurement values via a LIN bus.

Description

The Atmel ATmega64HVE2 is an 8-bit AVR microcontroller featuring a precise analog front end for highly accurate voltage and current measurements, an integrated temperature sensor as well as LIN bus connectivity. With these features the device fits perfect for Intelligent Battery Sensor (IBS) applications with monitoring of a starter battery's voltage, current flow and temperature.

The Atmel evaluation kit ATmega64HVE2-EK1 consists of an IBS module with a 100 $\mu\Omega$ current shunt and LIN bus connector, a reference board for IBS application with several ports and signals available for test purposes at the edges of the board, and a LIN master unit. The LIN master unit controls and reads out the IBS module which is configured as a LIN slave node. The LIN master unit features a USB connector to interface with the PC-based GUI that not only allows the IBS module to be controlled but also displays the measurement values in graphic form.

1. Kit Contents

Please check that your kit contains the following components (one of each):

- LIN master unit (consisting of control unit and LIN interface board)
- IBS module
- Reference design
- USB cable
- Power supply cable for LIN master unit (12V DC)
- LIN bus cable for interconnection between IBS module and LIN master unit and Vs power supply to the IBS module
- PC GUI software and sample IBS software for IBS module and reference design (all boards are preprogrammed) is available on the Atmel® website

Figure 1-1. LIN Master Unit

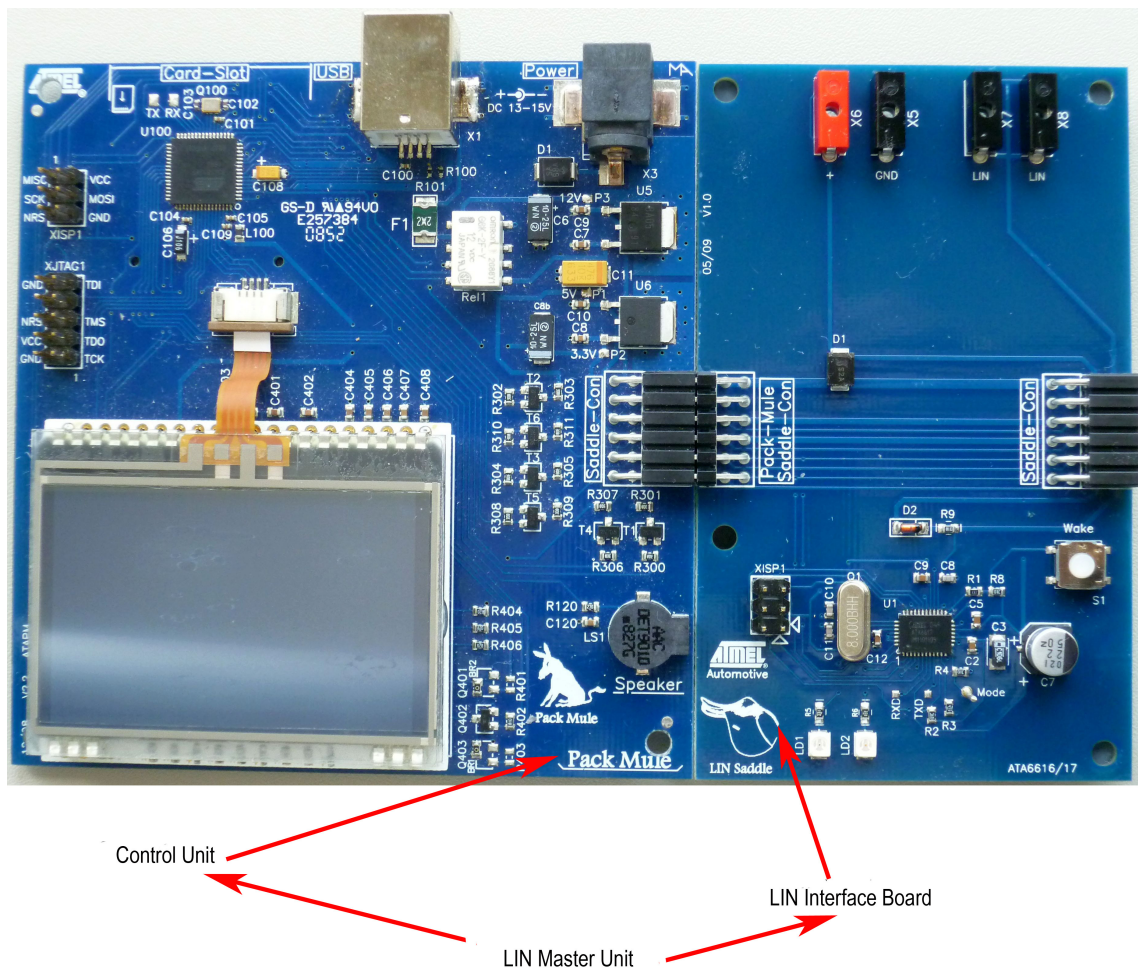

Figure 1-2. The IBS Module



Figure 1-3. Reference Design

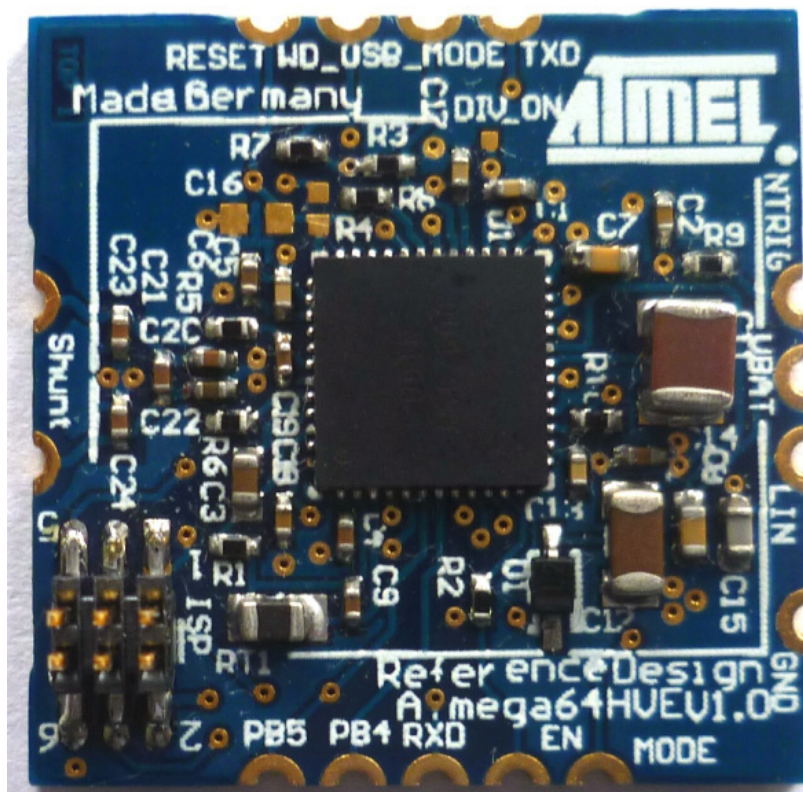

Figure 1-4. USB Cable



Figure 1-5. Power Supply Cable for LIN Master Unit (12V DC)



Figure 1-6. LIN Bus Cable

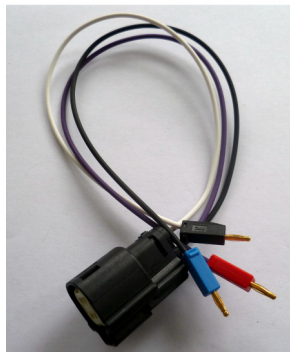

2. Setting Up the Kit

In order to set the kit up for operation, first install the GUI software on your PC.

Figure 2-1. Components of the Atmel ATmega64HVE2-EK1 Evaluation Kit

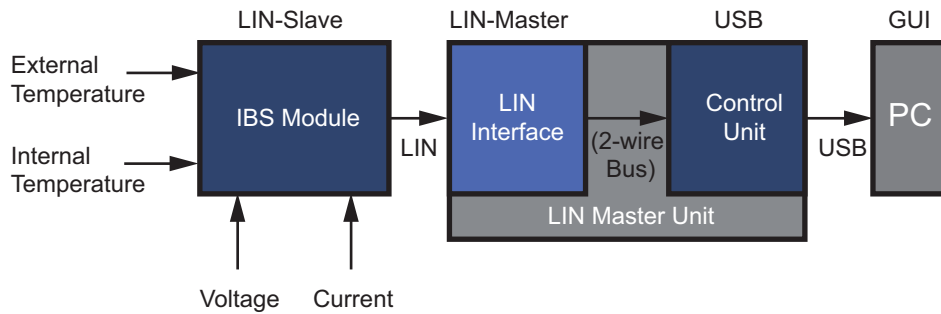
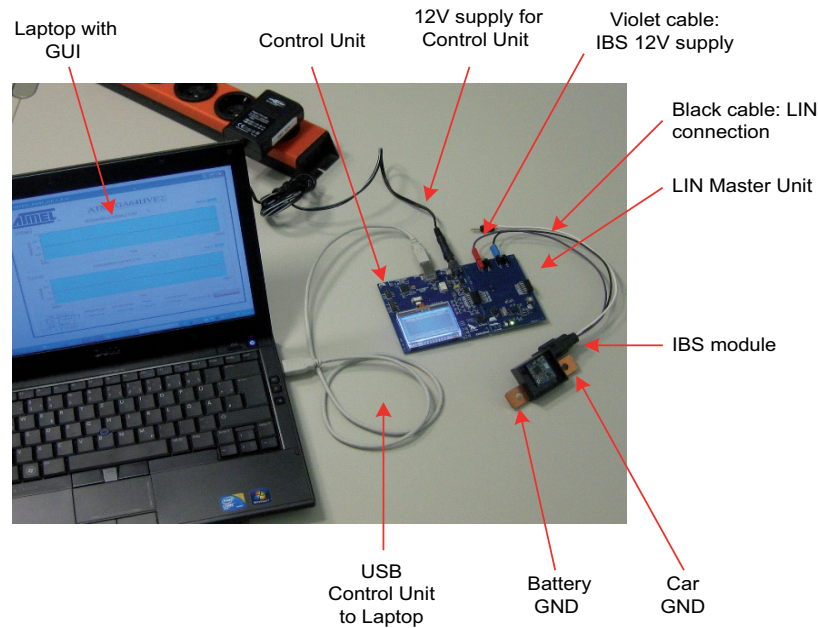

Figure 2-2. Atmel ATmega64HVE2-EK1 Evaluation Kit Setup



The LIN master unit consists of the LIN interface board (the light blue board in [Figure 2-1](#) and [Figure 2-2](#)) and the control unit board (dark blue) which are connected to each other via the on-board 2-wire bus connectors (Saddle-Con).

Connect the power supply cable to the Power supply plug on the LIN master unit. Provide 12V, minimum 100mA.

Figure 2-3. IBS Module Connections

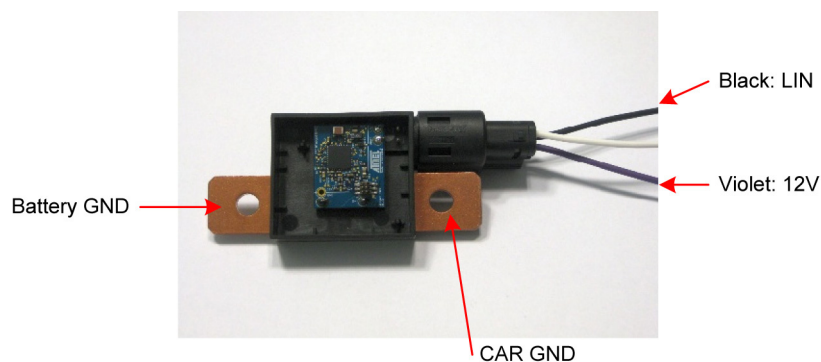

Connect the IBS module ([Figure 2-3](#)) to the LIN master unit via the LIN bus cable (black color) and connect the LIN master unit to a PC via the USB cable.

The IBS module needs to be supplied with battery voltage via the power supply cable (violet color). This voltage is normally the plus pole of the battery. This voltage level is measured by the IBS module. The supply voltage can be taken from the LIN control unit, connector X6.

2.1 Ground Connection

Figure 2-4. IBS Module - Bottom Left Corner

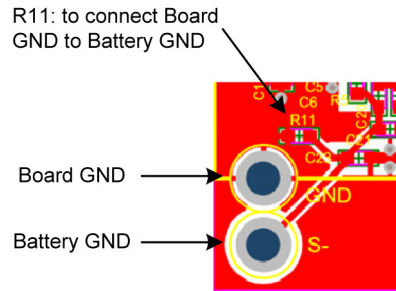

The hole 'Board GND' is the IBS module board ground, see [Figure 2-4](#).

The hole 'Battery GND' represents the ground pole of the battery. As default, the IBS module is connected to battery ground via R11. It's possible to ground the board separately. The ground connection can be done directly into the hole 'Board GND' instead of R11.

2.2 Current Measurement

The two clamps of the current shunt are on [Figure 2-3](#). The left clamp should be connected to the minus pole of the battery, the right clamp should be connected to the ground of the car.

2.3 Calibration

It's necessary to calibrate the Atmel ATmega64HVE2 software for achieving maximum measurement precision. The included application software already contains a calibration function with a separate calibration values EEPROM file.

As the calibration values depend on the whole system including the shunt, it's recommended to perform the calibration process at the end of production line.

Please be aware, the Atmel ATmega64HVE2 in the evaluation kit is not calibrated. For further information regarding the calibration process, please refer to the dedicated application note.

2.4 Reference Design Board

The reference design board included is intended for evaluation purposes. All signals are available as test points. This offers the possibility to evaluate own applications and software.

Programming of the IBS module or the reference design can be done via the mini ISP connector and standard Atmel® AVR® tools such as the JTAGICE mkII.

3. Installing the GUI Software

After downloading the GUI software, the folders and files can be found as indicated in [Figure 3-1](#).

Figure 3-1. Folders and Files of the Atmel ATmega64HVE2-EK1 Evaluation Kit GUI Software

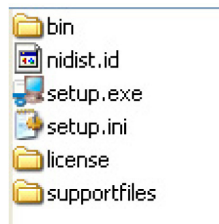

Ensure that no earlier version of the demonstrator GUI is installed on your system. If you double-click “setup.exe,” the window shown in [Figure 3-2](#) appears on your screen.

Figure 3-2. Start Window of Installation Process

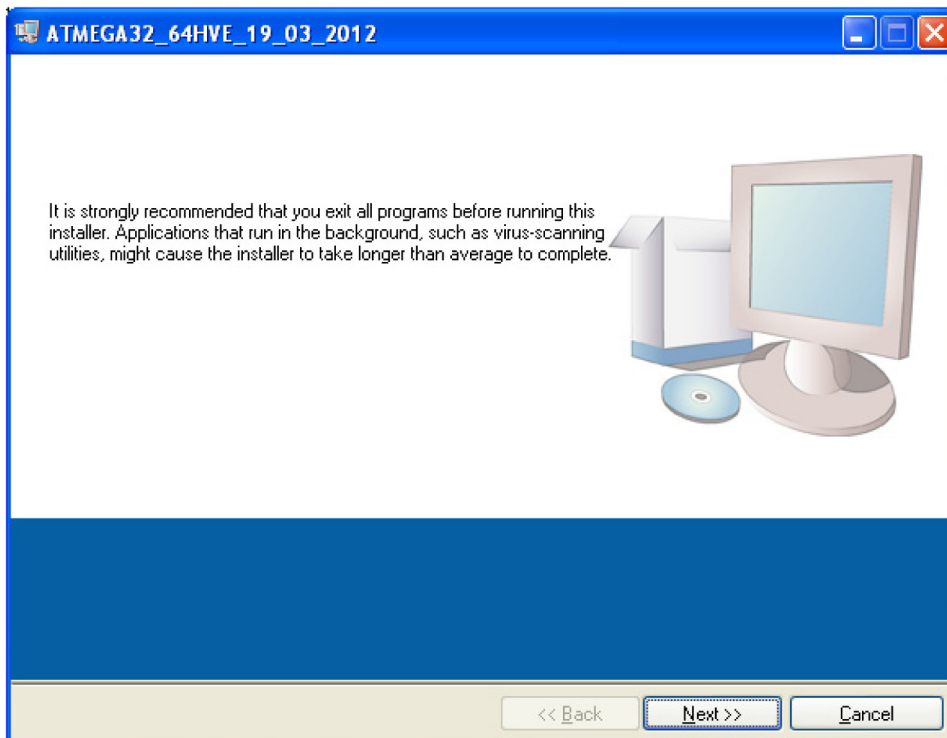

While clicking the “Next” button the windows as shown in [Figure 3-3](#) will appear on the screen subsequently. The installation progress is displayed until the last window in [Figure 3-3](#) appears. This means the installation has been successfully completed.

Figure 3-3. Displayed Windows during Installation Process

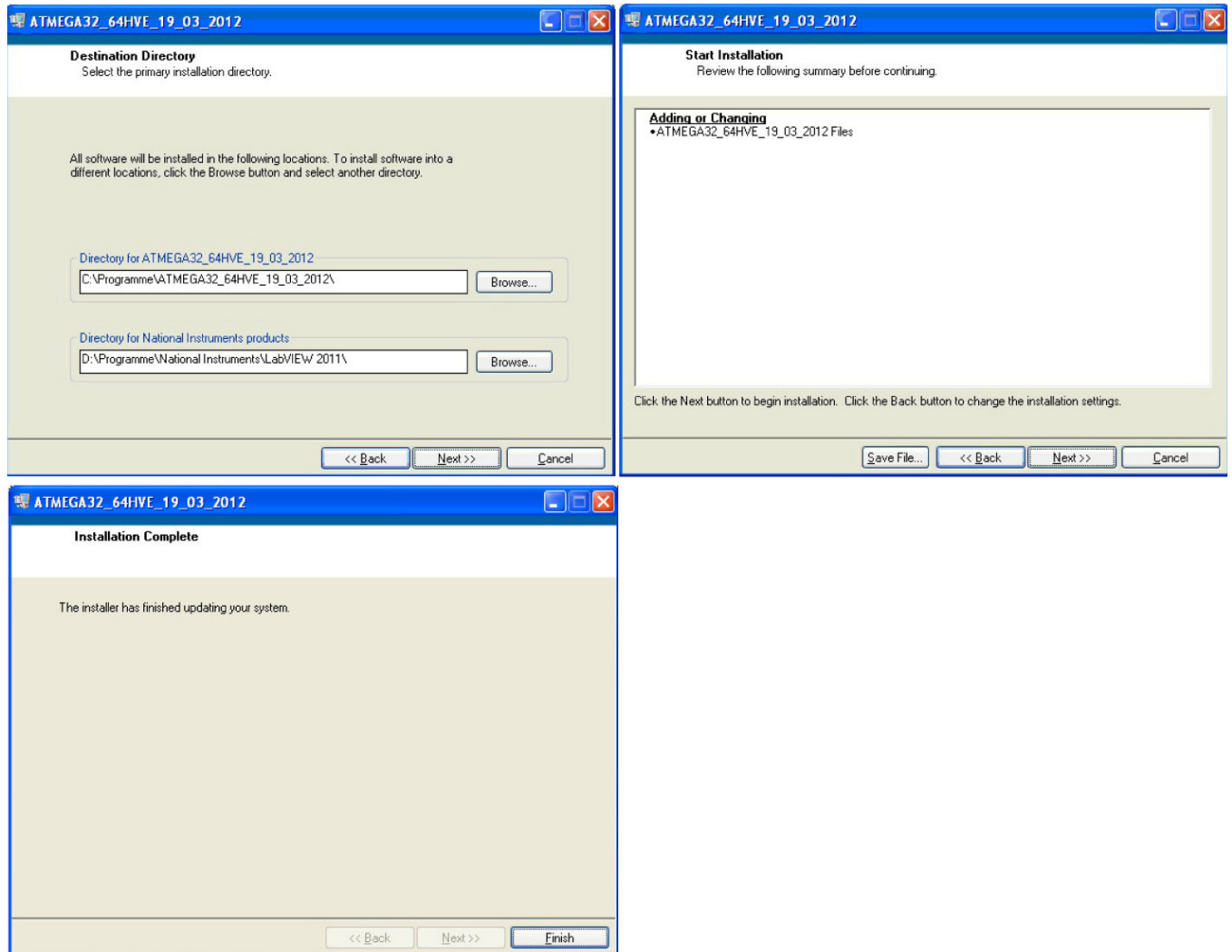

When the installation is complete, simply click on the “Finish” button. No special drivers need to be installed to drive the USB interface. A new group should then appear in the “Start” menu as shown in [Figure 3-4](#).

Figure 3-4. Start Menu Group for Atmel ATmega64HVE2-EK1 Evaluation Kit GUI Software



4. The GUI

Once the boards and power sources are connected as described above and the GUI is installed, double-click the Atmel® ATMEGA64HVE2 symbol in the “Start” menu to launch the GUI. The GUI immediately starts to receive data from the IBS module (Figure 4-1).

Following parameters are featured:

- Battery voltage
- Battery current
- Atmel ATmega64HVE2 temperature
- IBS module temperature

Figure 4-1. Main Window of the GUI with Voltage and Current Measurement Displayed versus Elapsed Time

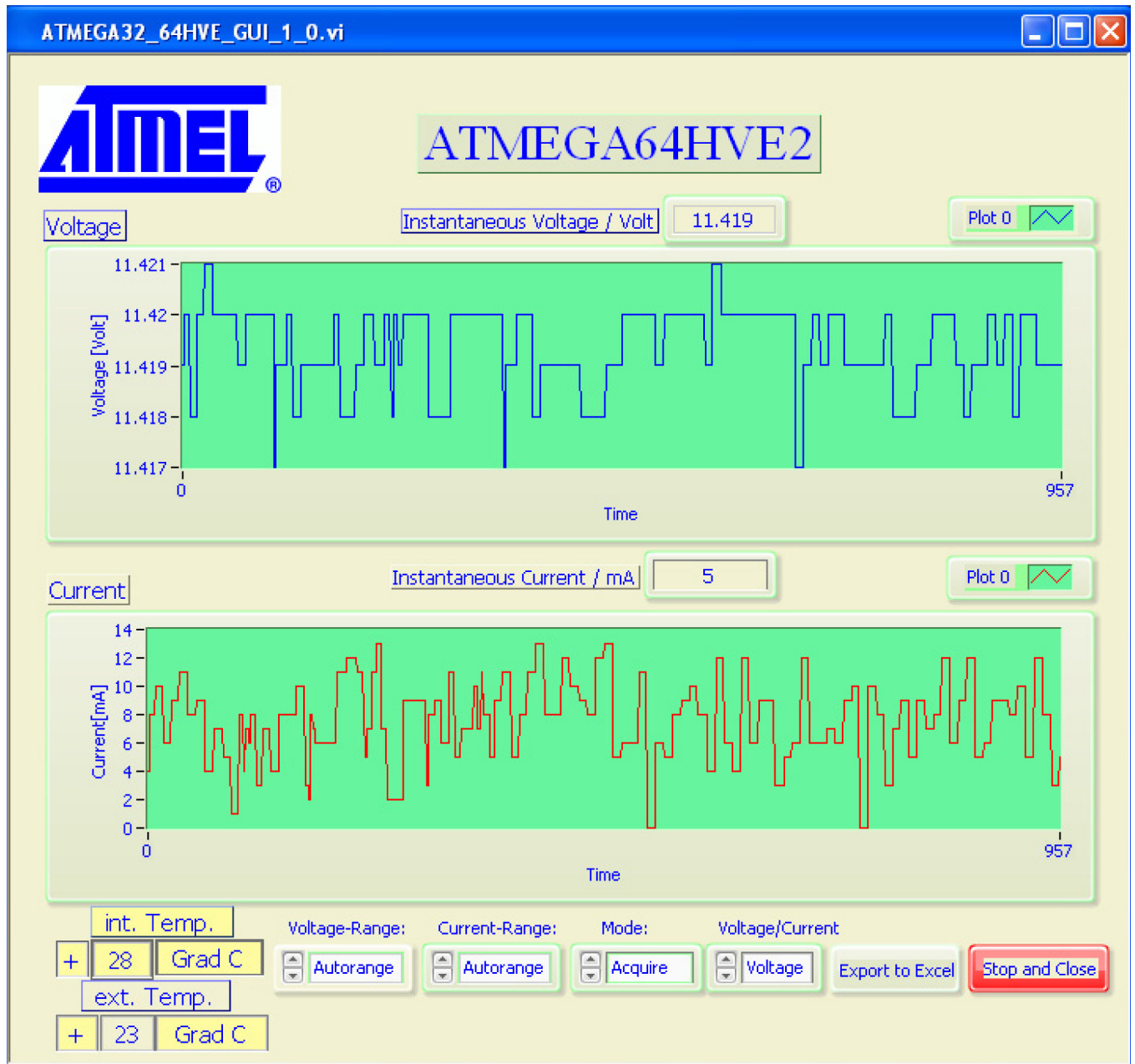

The LCD display of the LIN master unit monitors the instantaneous measured values as well (see [Figure 4-2](#)).

Figure 4-2. Instantaneous Measurement Values on the LCD Display of the LIN Master Unit



The main window of the Atmel ATmega64HVE2-EK1 GUI consists of two graphs for displaying the measured voltage and the current values versus elapsed time; in addition, the instantaneous numeric values of voltage and current plus internal and external temperature are shown as well. While the measured voltage is the IBS module supply voltage V_s , the current values remain close to zero as long as no load is connected via the shunt resistor to V_s . In addition to the IC internal temperature sensor, an external sensor (thermistor) is included on the IBS module. Typically the internal temperature values will be slightly higher than the external ones due to IC power dissipation.

The voltage and current measurement can either be set to "Autorange" or to a fixed range if the values are expected to be within that range. The regular operating mode is "Acquire" but the measurement can be paused any time by selecting "Stop" in the mode selector. Finally, the GUI also allows the voltage or current values to be exported to MS Excel by clicking on the related button and choosing the desired option. [Figure 4-3](#) shows how exporting the data works.

Figure 4-3. Exporting Voltage or Current Measurement Values to MS Excel

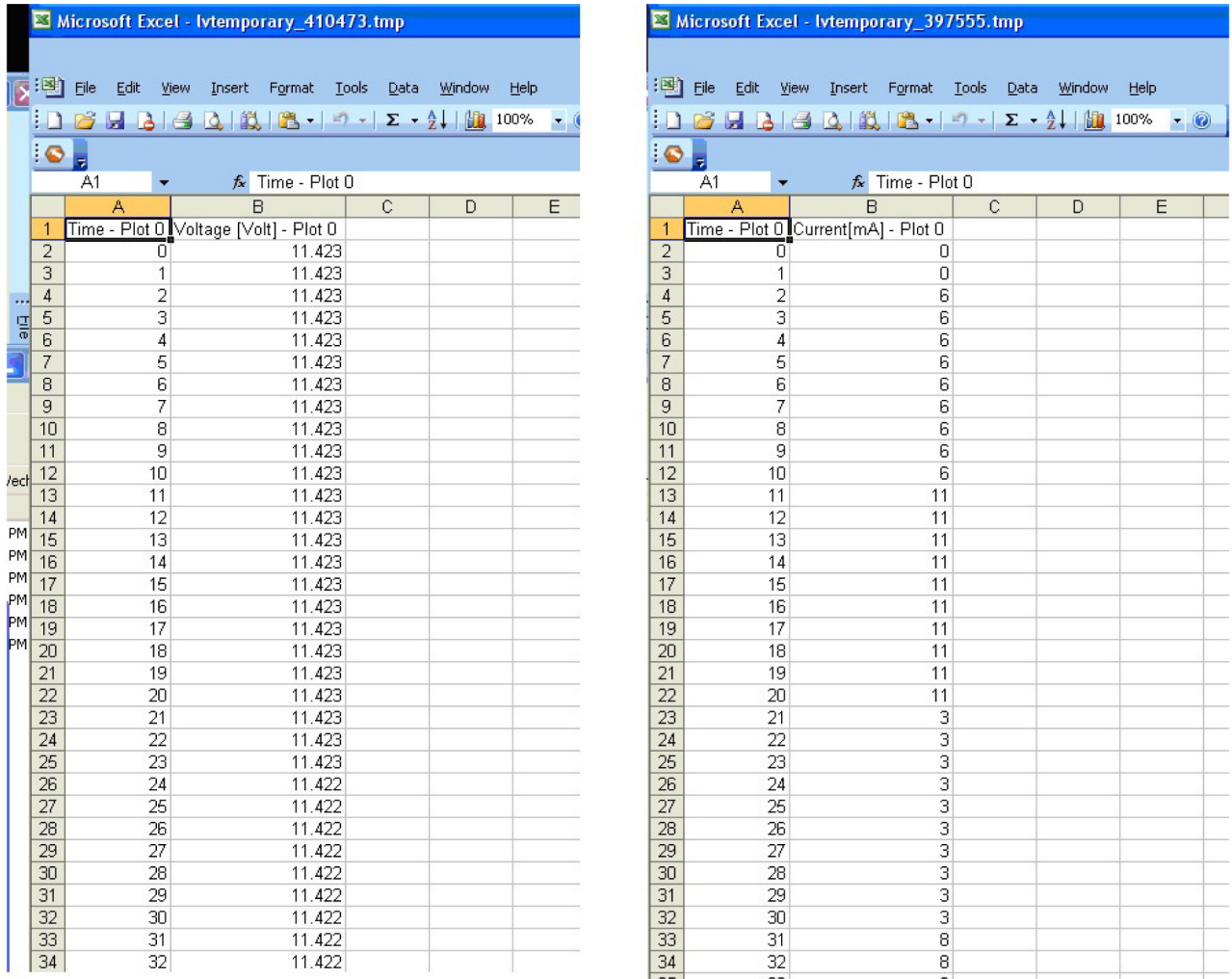

4.1 Stopping the GUI

Please be sure to always stop the GUI using the “Stop and Close” button. Not using this button may cause the USB interface to fail to close properly and produce an error message.

5. Board Documentation of IBS Module and Reference Design

Figure 5-1. Schematic of the IBS Module

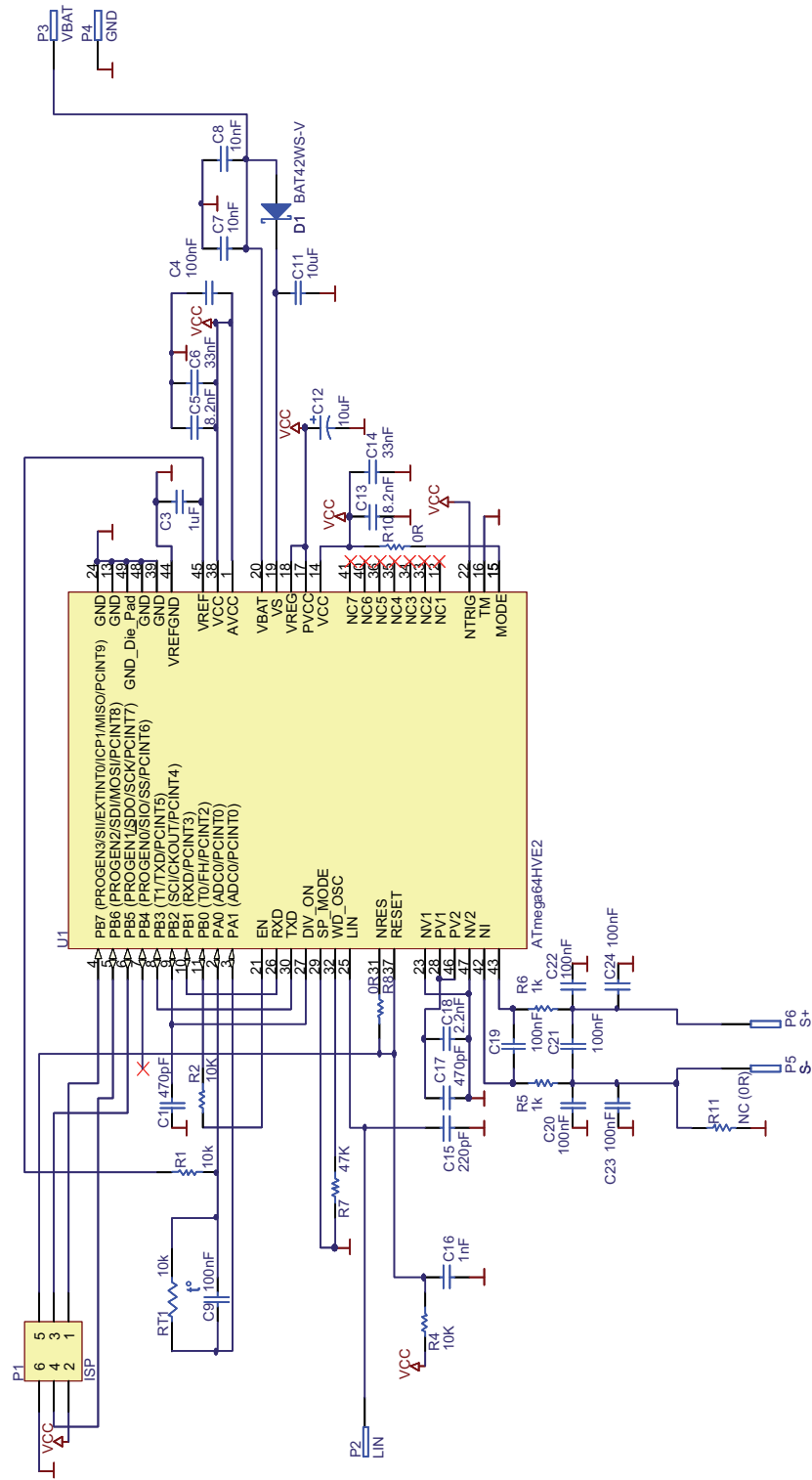

Figure 5-2. PCB Layout of the IBS Module, Top Layer (View: Top Layer)

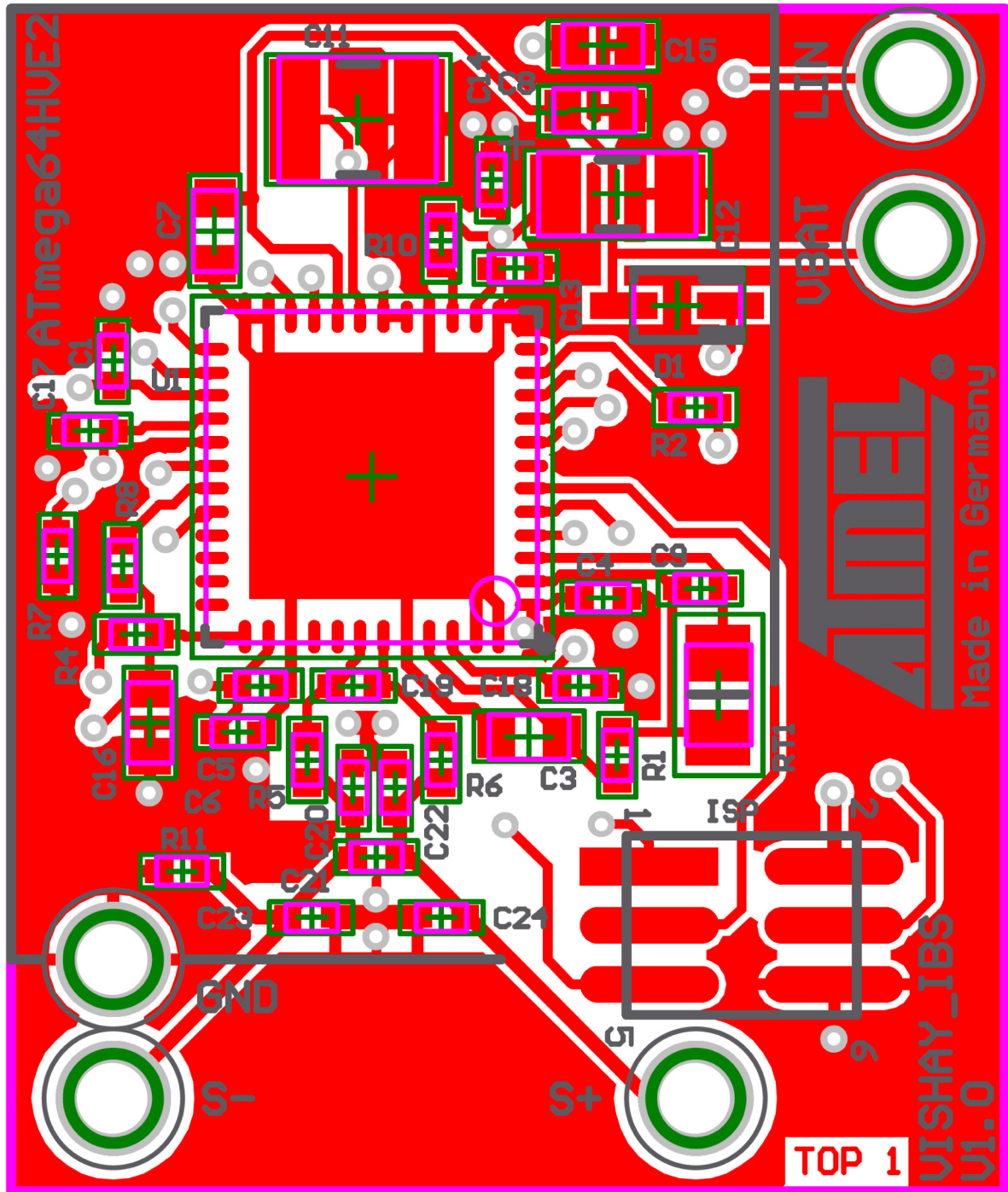

Figure 5-3. PCB Layout of IBS Module, Mid Layer 1 (View: Top Layer)

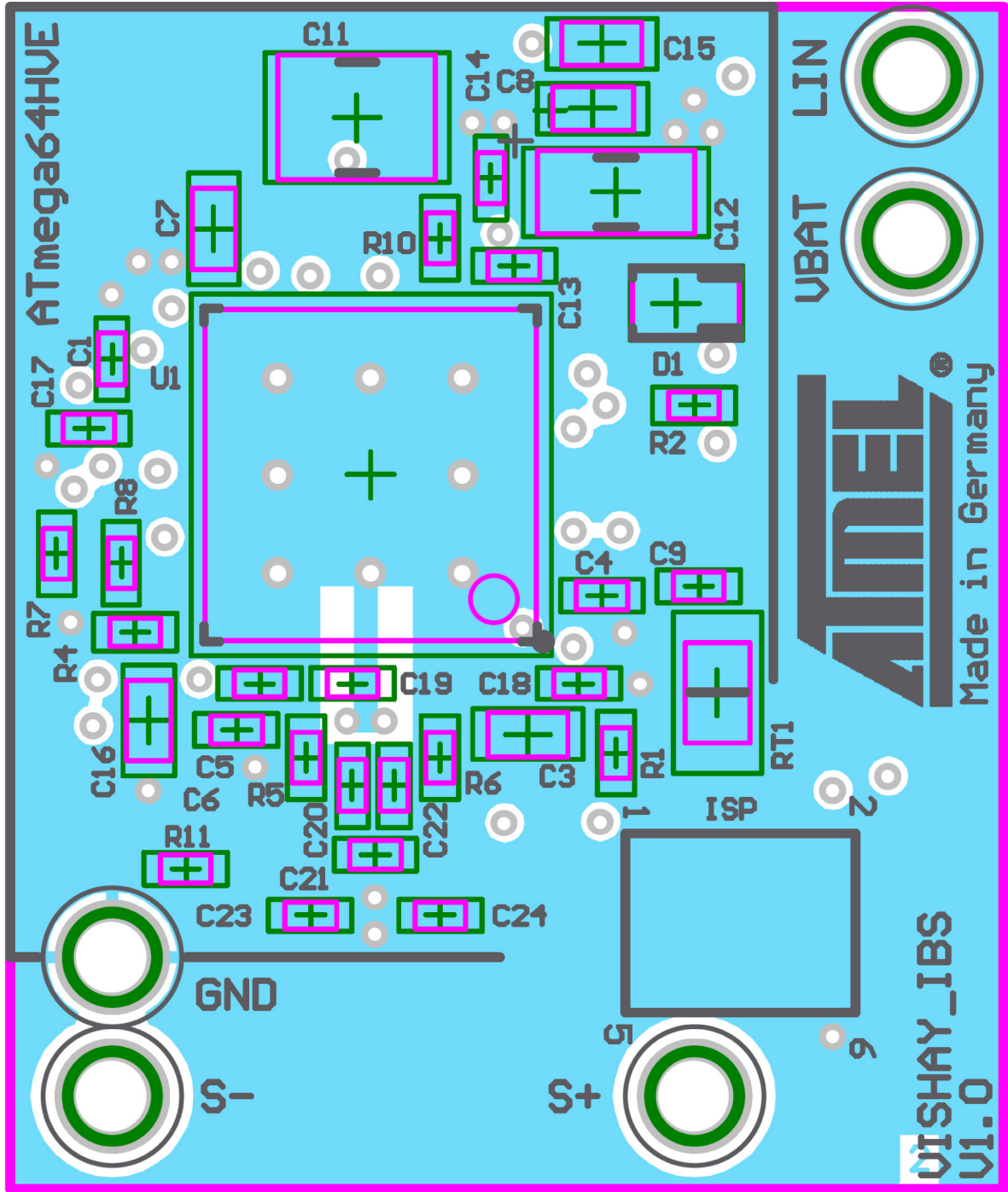

Figure 5-4. PCB Layout of IBS Module, Mid Layer 2 (View: Top Layer)

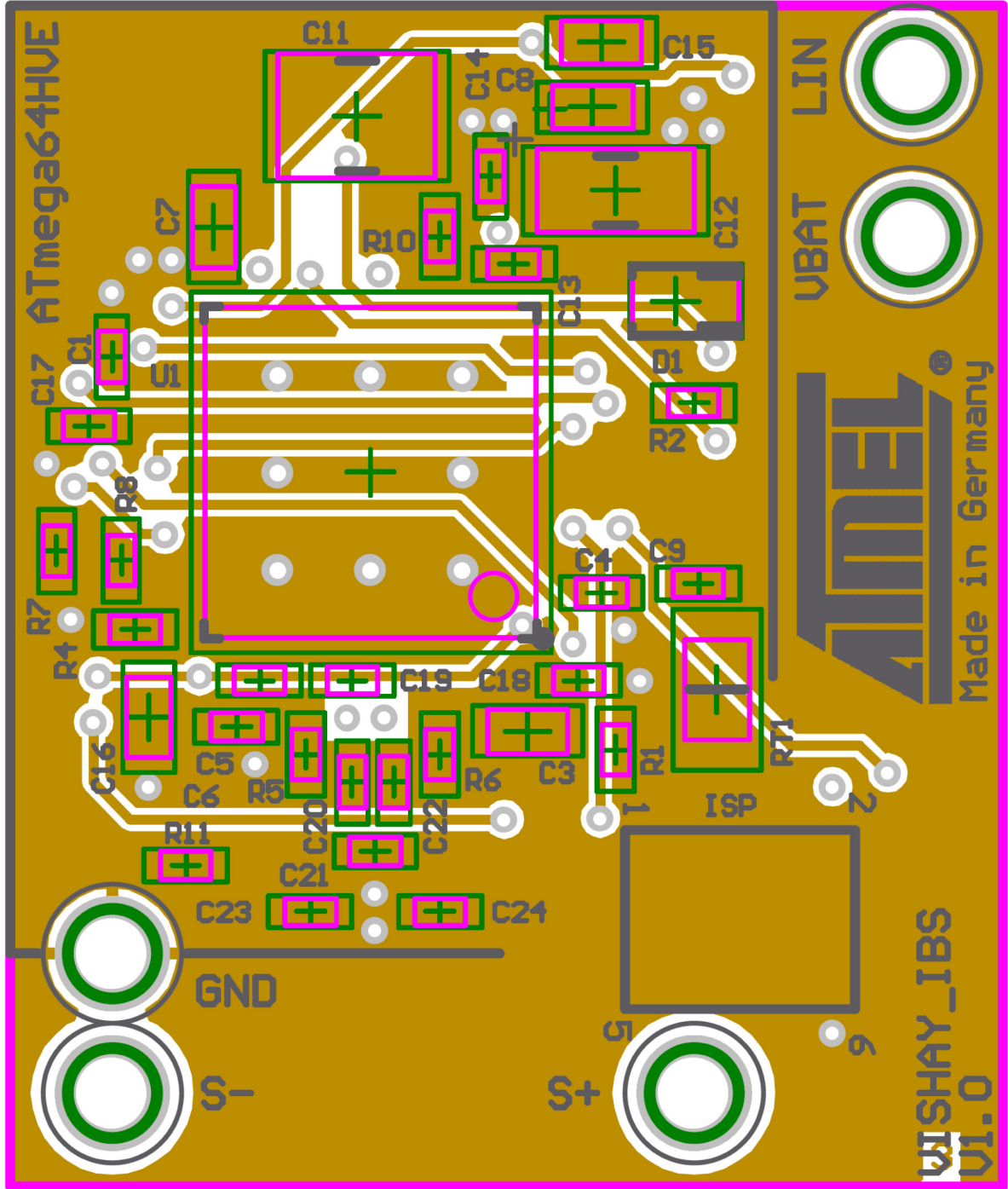

Figure 5-5. PCB Layout of IBS Module, Bottom Layer (View: Top Layer)

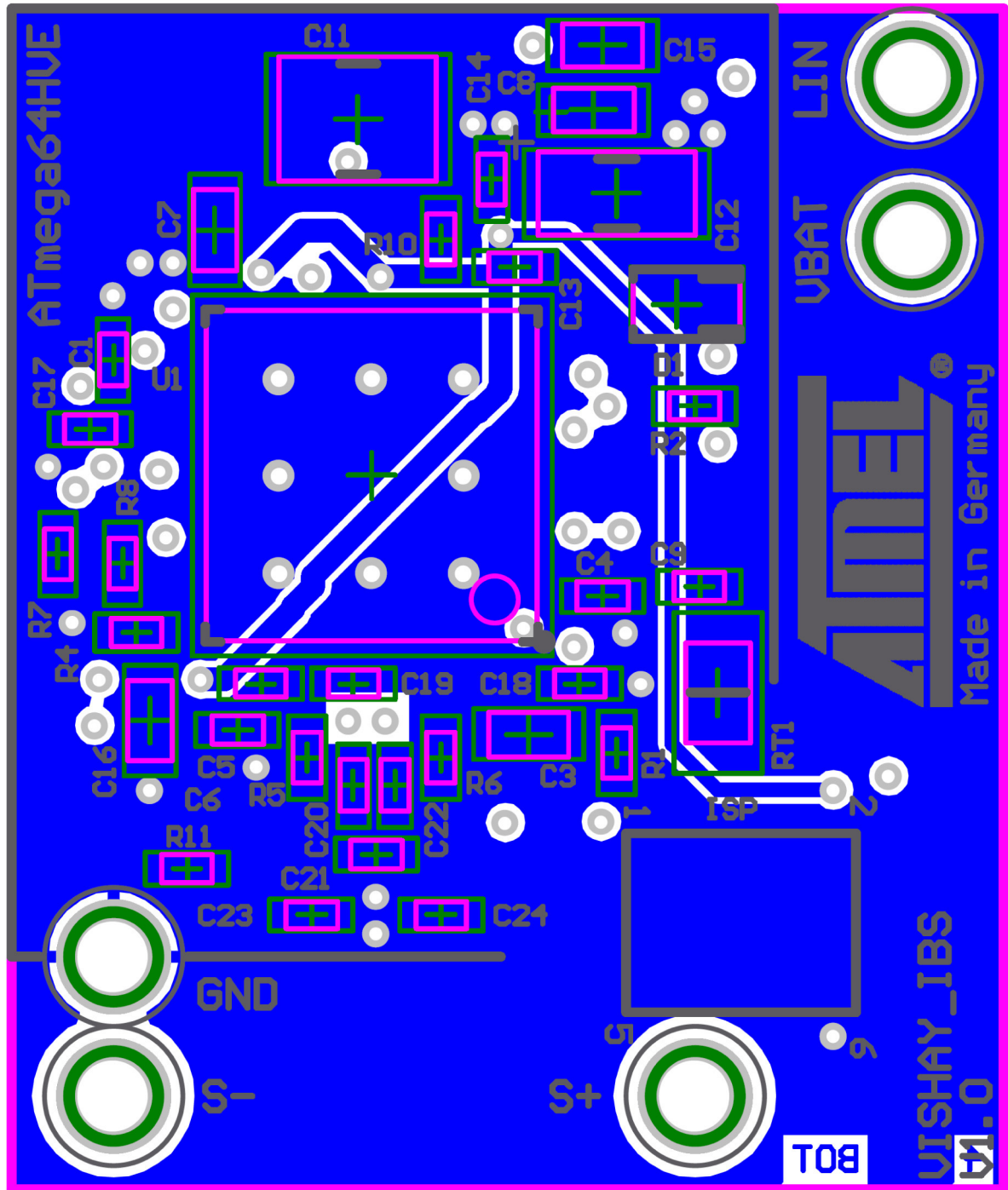

Table 5-1. IBS Module Bill of Material

Designator	Value	Description	Footprint
C1, C17	470pF	Ceramic Capacitor X7R 10V	1005L
C3	1μF	Ceramic Capacitor X7R 10V	1608L
C4, C9, C19, C20, C21, C22, C23, C24	100nF	Ceramic Capacitor X7R 10V	1005L
C5, C13	8.2nF	Ceramic Capacitor X7R 10V	1005L
C6, C14	33nF	Ceramic Capacitor X7R 10V	1005L
C7, C8	10nF	Ceramic Capacitor X7R 50V, i.e., AVX 06035C103K4Z2A	1608L
C11	10μF	Ceramic Capacitor 50V, i.e., TDK C3225X7S1H106M/SOFT	3225L
C12	10μF	Polarized Capacitor (10V, Electrolytic/Tantalum)	3216L
C15	220pF	Ceramic Capacitor X7R 10V	1608L
C16	1nF	Ceramic Capacitor X7R 10V	1608L
C18	2.2nF	Ceramic Capacitor X7R 10V	1005L
D1	BAT42WS-V	Schottky Diode Vishay	SOD323
P1	ISP	Samtec FTSH-103-01-L-DV	
P2	LIN	Connector Pad	
P3	VBAT	Connector Pad	
P4	GND	Connector Pad	
P5	S-	Connector Pad to Shunt	
P6	S+	Connector Pad to Shunt	
Shunt	WSBS8518L1000JK	Vishay Battery Shunt, http://www.vishay.com/docs/30134/wsbs8518.pdf	
R1, R2, R4	10k	Resistor 50V	1005L
R5, R6	1k	Resistor 50V	1005L
R7	47k	Resistor 50V	1005L
R8, R10	0R	Resistor 50V	1005L
R11	NC (0R)	Resistor 50V	1005L
RT1	10k	NTC Thermistor Epcos B57471V2103J62	2012N
U1	ATmega64HVE	8-Bit AVR Microcontroller	QFN48

Figure 5-6. Schematic of Reference Design

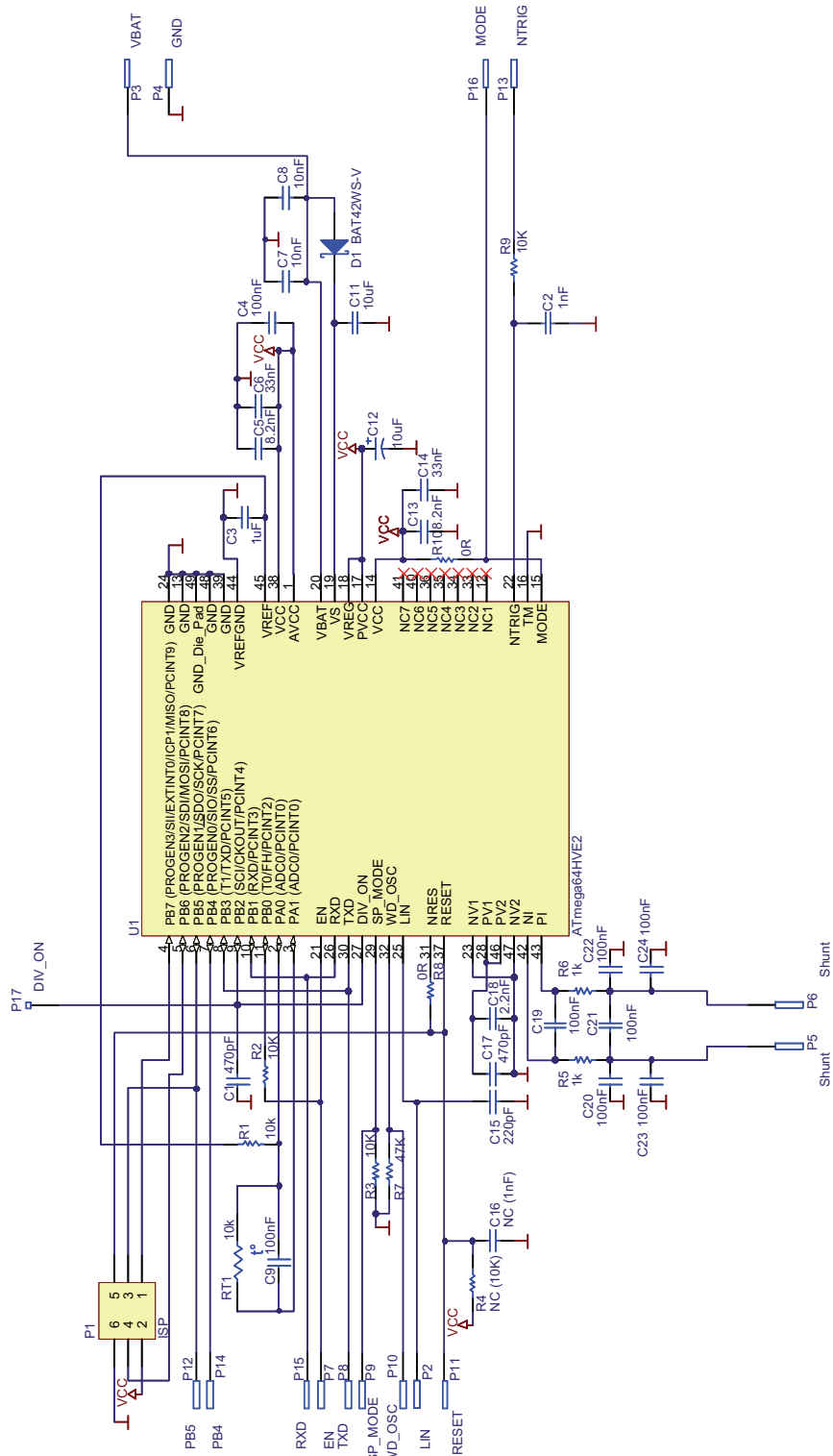

Figure 5-7. PCB Layout of Reference Design, Top Layer (View: Top Layer)

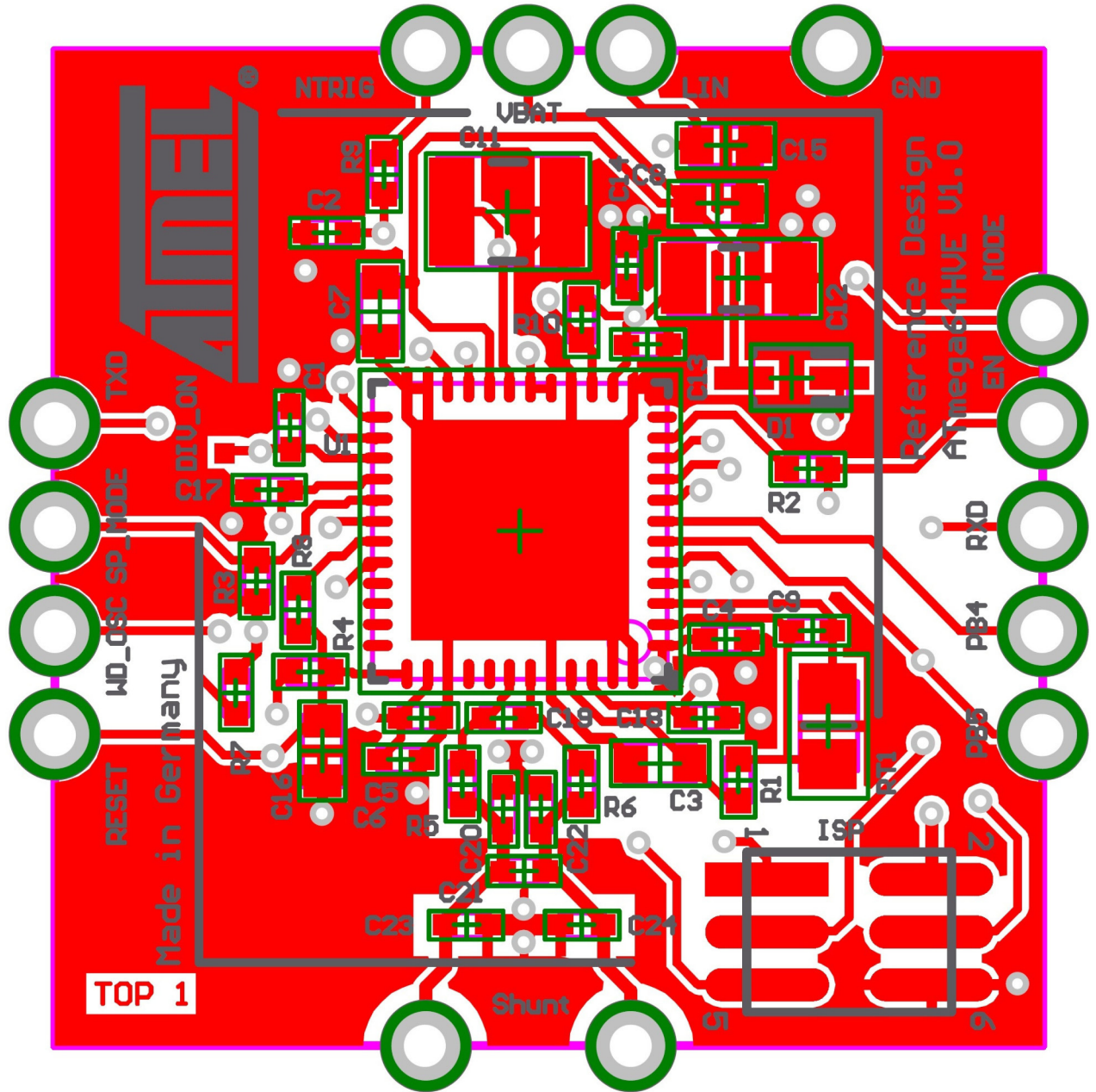

Figure 5-8. PCB Layout of Reference Design, Mid Layer 1 (View: Top Layer)

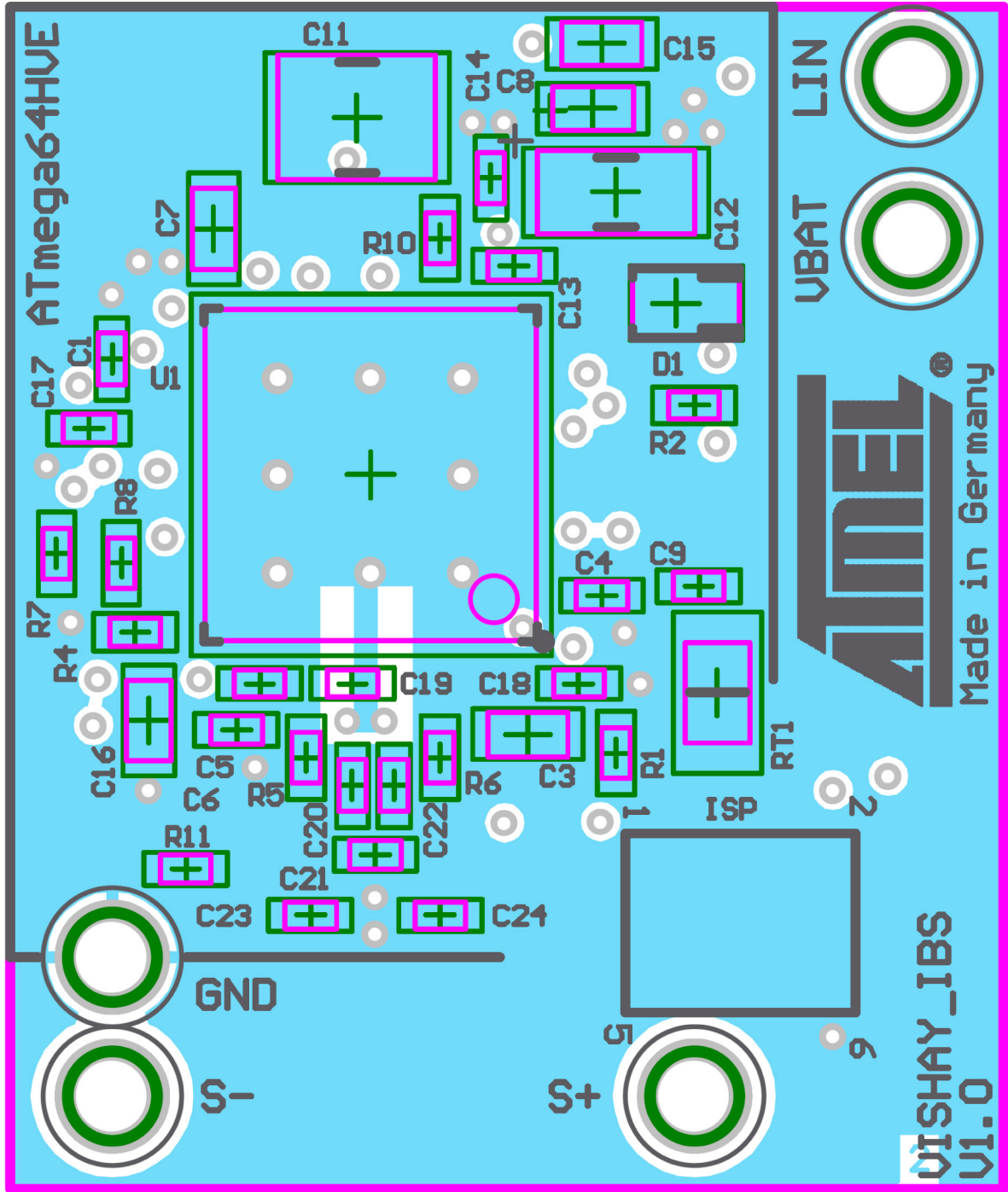

Figure 5-10. PCB Layout of Reference Design, Bottom Layer (View: Top Layer)

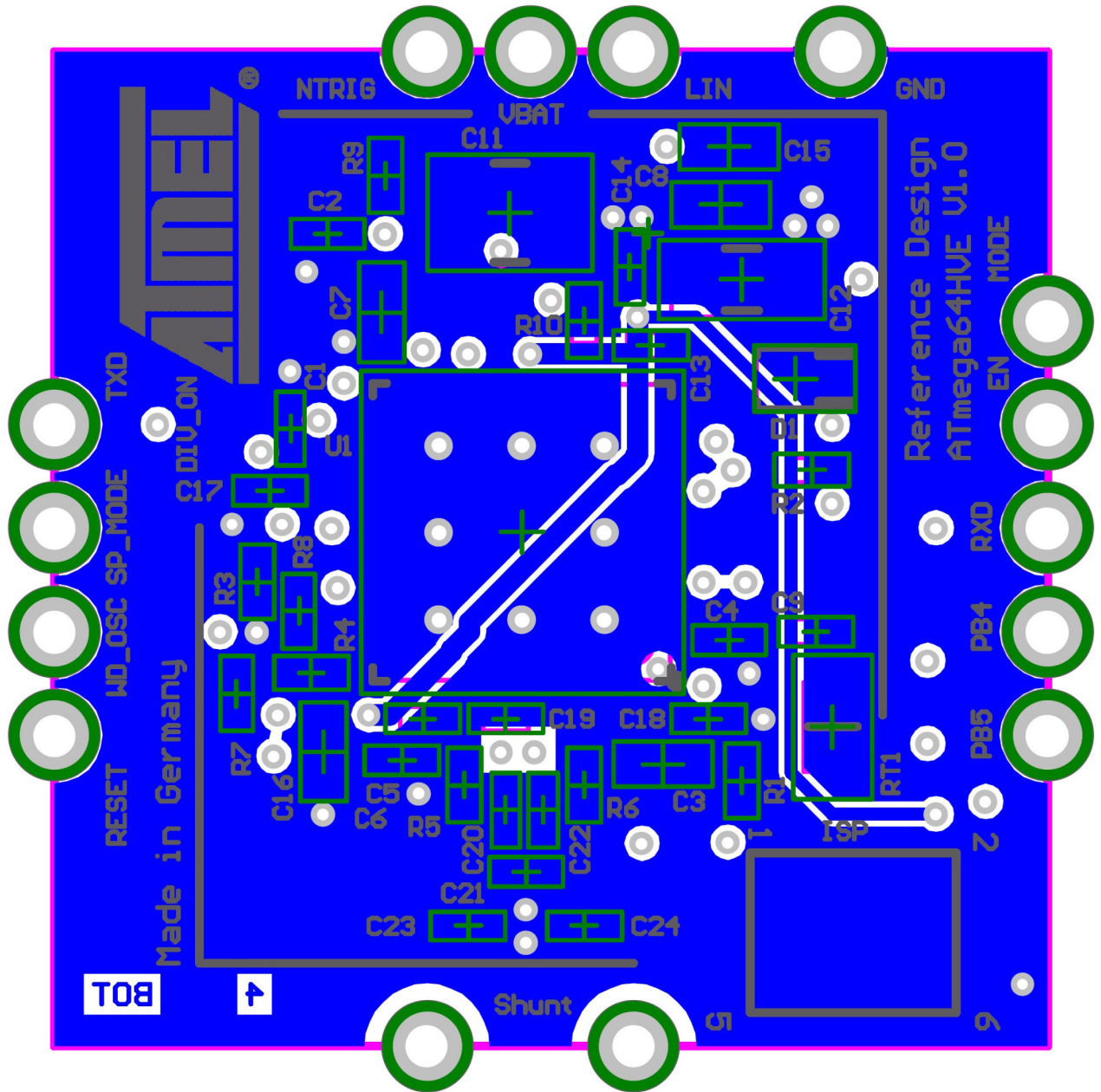

Table 5-2. Reference Design Bill of Material

Designator	Value	Description	Footprint
C1, C17	470pF	Ceramic Capacitor X7R 10V	1005L
C2	1nF	Ceramic Capacitor X7R 10V	1005L
C3	1μF	Ceramic Capacitor X7R 10V	1608L
C4, C9, C19, C20, C21, C22, C23, C24	100nF	Ceramic Capacitor X7R 10V	1005L
C5, C13	8.2nF	Ceramic Capacitor X7R 10V	1005L
C6, C14	33nF	Ceramic Capacitor X7R 10V	1005L
C7, C8	10nF	Ceramic Capacitor X7R 50V, i.e., AVX 06035C103K4Z2A	1608L
C11	10μF	Ceramic Capacitor 50V, i.e., TDK C3225X7S1H106M/SOFT	3225L
C12	10μF	Polarized Capacitor (10V, Electrolytic/Tantalum)	3216L
C15	220pF	Ceramic Capacitor X7R 10V	1608L
C16	NC (1nF)	Ceramic Capacitor X7R 10V	1608L
C18	2.2nF	Ceramic Capacitor X7R 10V	1005L
D1	BAT42WS-V	Schottky Diode Vishay	SOD323
P1	ISP	Samtec FTSH-103-01-L-DV	
P2	LIN	Border Connection Pad	
P3	VBAT	Border Connection Pad	
P4	GND	Border Connection Pad	
P5, P6	Shunt	Border Connection Pad	
P7	EN	Border Connection Pad	
P8	TXD	Border Connection Pad	
P9	SP_MODE	Border Connection Pad	
P10	WD_OSC	Border Connection Pad	
P11	RESET	Border Connection Pad	
P12	PB5	Border Connection Pad	
P13	NTRIG	Border Connection Pad	
P14	PB4	Border Connection Pad	
P15	RXD	Border Connection Pad	
P16	MODE	Border Connection Pad	
P17	DIV_ON	Test Pad	
R1, R2, R3, R9	10k	Resistor 50V	1005L
R4	NC (10K)	Resistor 50V	1005L
R5, R6	1k	Resistor 50V	1005L
R7	47K	Resistor 50V	1005L
R8, R10	0R	Resistor 50V	1005L
RT1	10k	NTC thermistor Epcos B57471V2103J62	2012N
U1	ATmega64HVE2	8-Bit AVR Microcontroller	QFN48

6. Revision History

Please note that the following page numbers referred to in this section refer to the specific revision mentioned, not to this document.

Revision No.	History
9283B-AVR-10/12	<ul style="list-style-type: none">• Section 2.1 “Ground Connection” on page 6 updated• Section 2.3 “Calibration” on page 6 added



Enabling Unlimited Possibilities™

Atmel Corporation

2325 Orchard Parkway
San Jose, CA 95131
USA

Tel: (+1) (408) 441-0311

Fax: (+1) (408) 487-2600

www.atmel.com

Atmel Asia Limited

Unit 01-5 & 16, 19F
BEA Tower, Millennium City 5
418 Kwun Tong Roa
Kwun Tong, Kowloon

HONG KONG

Tel: (+852) 2245-6100

Fax: (+852) 2722-1369

Atmel Munich GmbH

Business Campus
Parkring 4
D-85748 Garching b. Munich
GERMANY

Tel: (+49) 89-31970-0

Fax: (+49) 89-3194621

Atmel Japan G.K.

16F Shin-Osaki Kangyo Building
1-6-4 Osaki
Shinagawa-ku, Tokyo 141-0032
JAPAN

Tel: (+81) (3) 6417-0300

Fax: (+81) (3) 6417-0370

© 2012 Atmel Corporation. All rights reserved. / Rev.: 9283B-AVR-10/12

Atmel®, Atmel logo and combinations thereof, Enabling Unlimited Possibilities®, and others are registered trademarks or trademarks of Atmel Corporation or its subsidiaries. Other terms and product names may be trademarks of others.

Disclaimer: The information in this document is provided in connection with Atmel products. No license, express or implied, by estoppel or otherwise, to any intellectual property right is granted by this document or in connection with the sale of Atmel products. EXCEPT AS SET FORTH IN THE ATMEL TERMS AND CONDITIONS OF SALES LOCATED ON THE ATMEL WEBSITE, ATMEL ASSUMES NO LIABILITY WHATSOEVER AND DISCLAIMS ANY EXPRESS, IMPLIED OR STATUTORY WARRANTY RELATING TO ITS PRODUCTS INCLUDING, BUT NOT LIMITED TO, THE IMPLIED WARRANTY OF MERCHANTABILITY, FITNESS FOR A PARTICULAR PURPOSE, OR NON-INFRINGEMENT. IN NO EVENT SHALL ATMEL BE LIABLE FOR ANY DIRECT, INDIRECT, CONSEQUENTIAL, PUNITIVE, SPECIAL OR INCIDENTAL DAMAGES (INCLUDING, WITHOUT LIMITATION, DAMAGES FOR LOSS AND PROFITS, BUSINESS INTERRUPTION, OR LOSS OF INFORMATION) ARISING OUT OF THE USE OR INABILITY TO USE THIS DOCUMENT, EVEN IF ATMEL HAS BEEN ADVISED OF THE POSSIBILITY OF SUCH DAMAGES. Atmel makes no representations or warranties with respect to the accuracy or completeness of the contents of this document and reserves the right to make changes to specifications and products descriptions at any time without notice. Atmel does not make any commitment to update the information contained herein. Unless specifically provided otherwise, Atmel products are not suitable for, and shall not be used in, automotive applications. Atmel products are not intended, authorized, or warranted for use as components in applications intended to support or sustain life.