

THIS DRAWING IS UNPUBLISHED. RELEASED FOR PUBLICATION. ALL RIGHTS RESERVED.

LOC	DIST	REVISIONS					
AF	50	P	LTR	DESCRIPTION	DATE	DWN	APVD
		L1		REVISED PER ECO-11-004917	11MAR11	RK	HMR

SUGGESTED MATING TAB

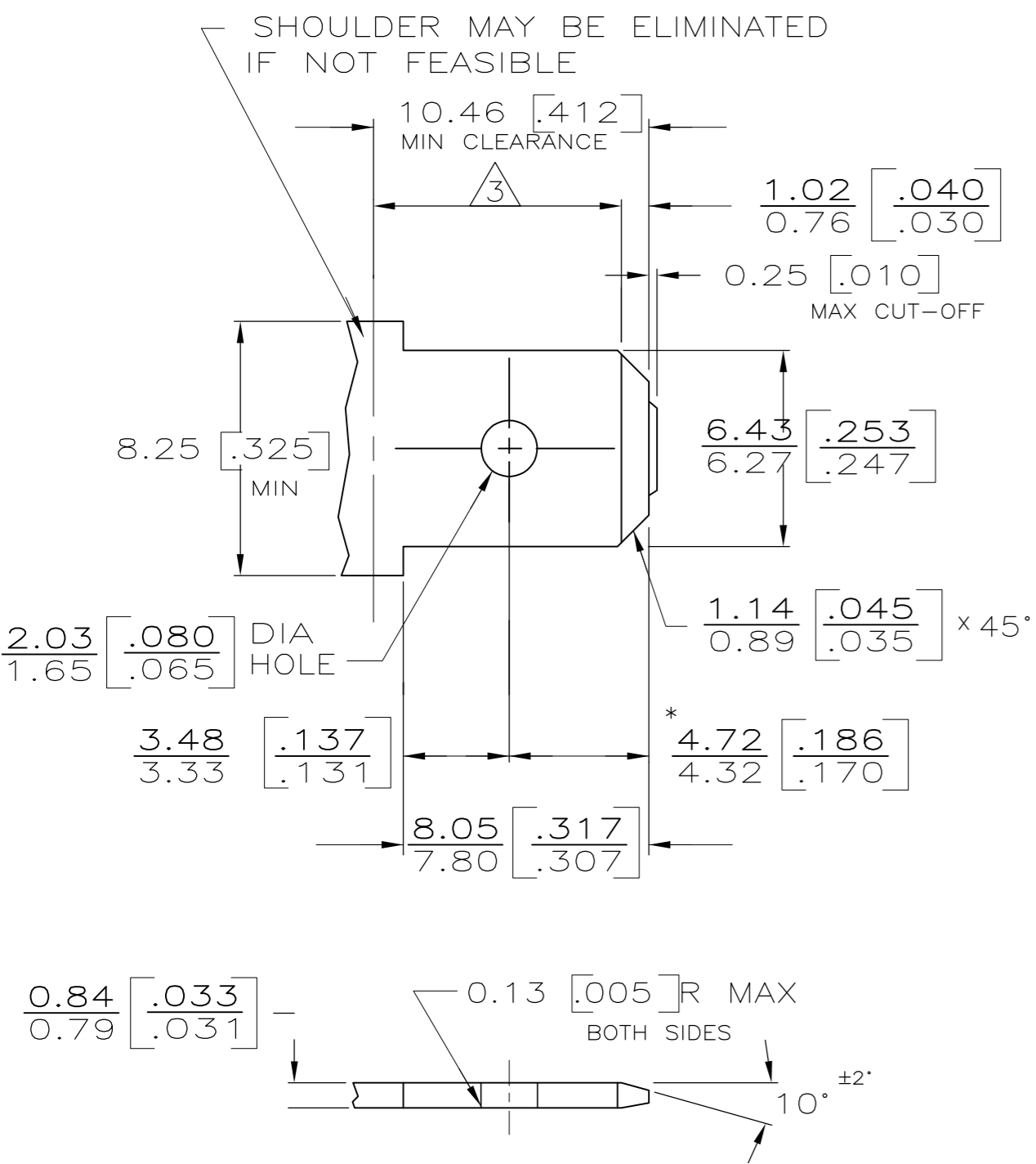

- 1 - MATL: 1/2H BRASS OR NICKEL PL STEEL.
 - 2 - NO BURRS PERMISSIBLE AT HOLE.
 - 3 - MUST BE FLAT WITHIN 0.076 [.003] OVER THIS LENGTH.
 - 4 - TIN PLATING IS REQUIRED ON BRASS WHEN TERMINAL TEMP. IS OVER 225°F.
 - 5 - HOLE MUST BE SYMMETRICAL ABOUT TAB Q WITHIN 0.076 [.003]
- * TO BE USED ONLY WHEN SHOULDER IS ELIMINATED.

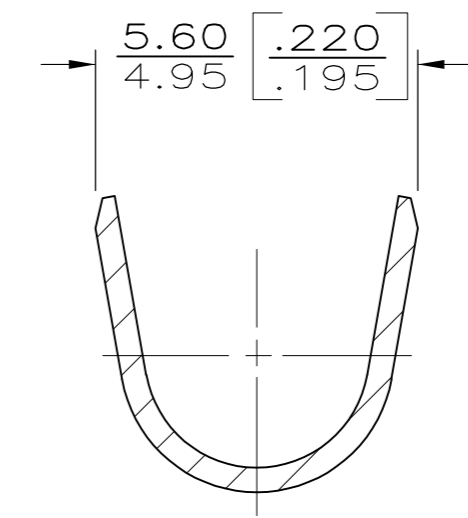
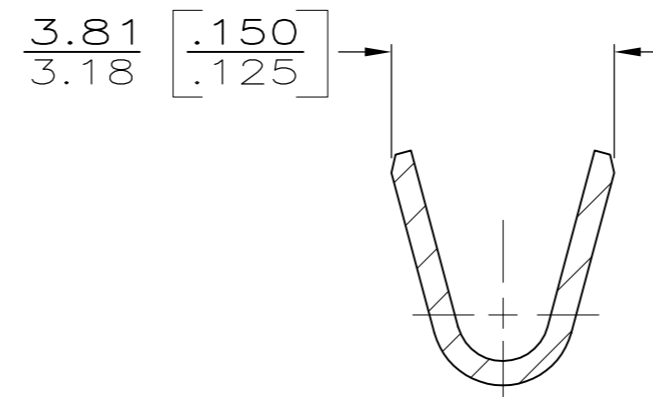
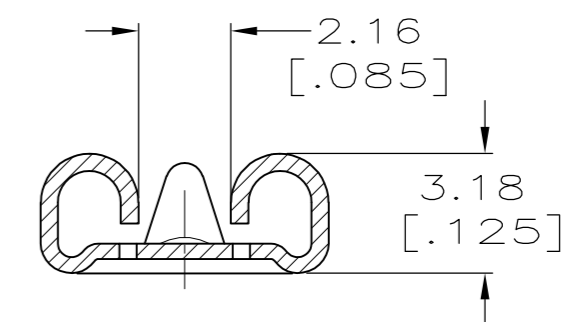
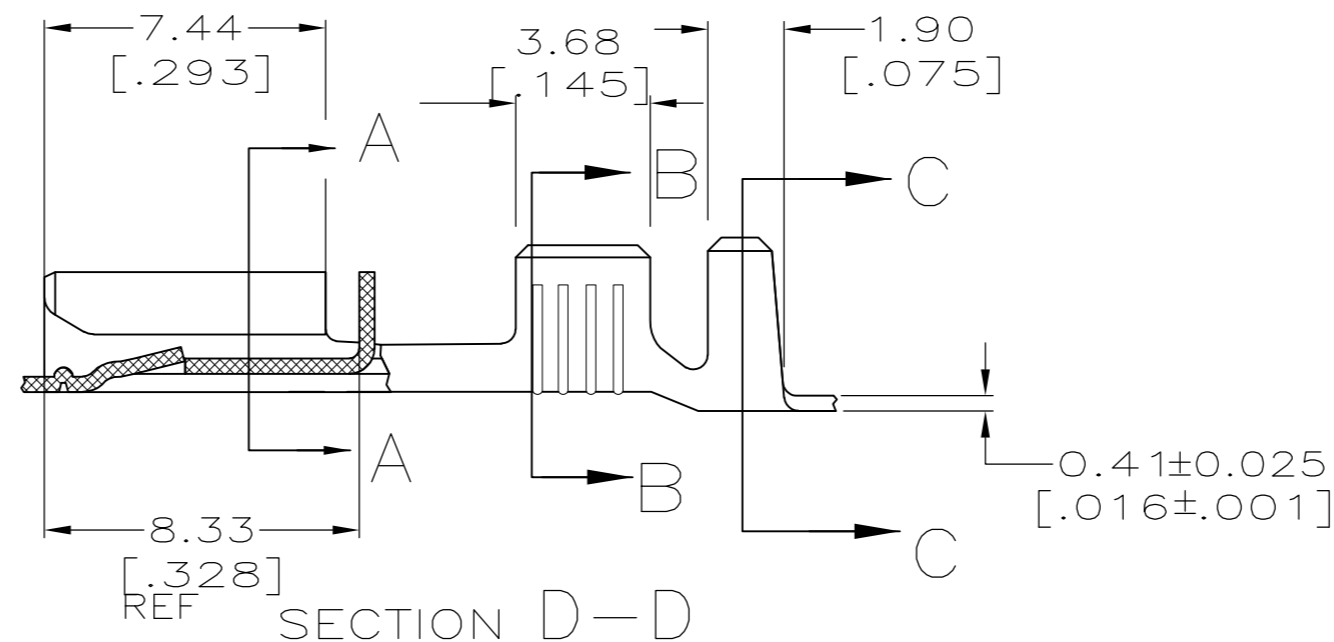
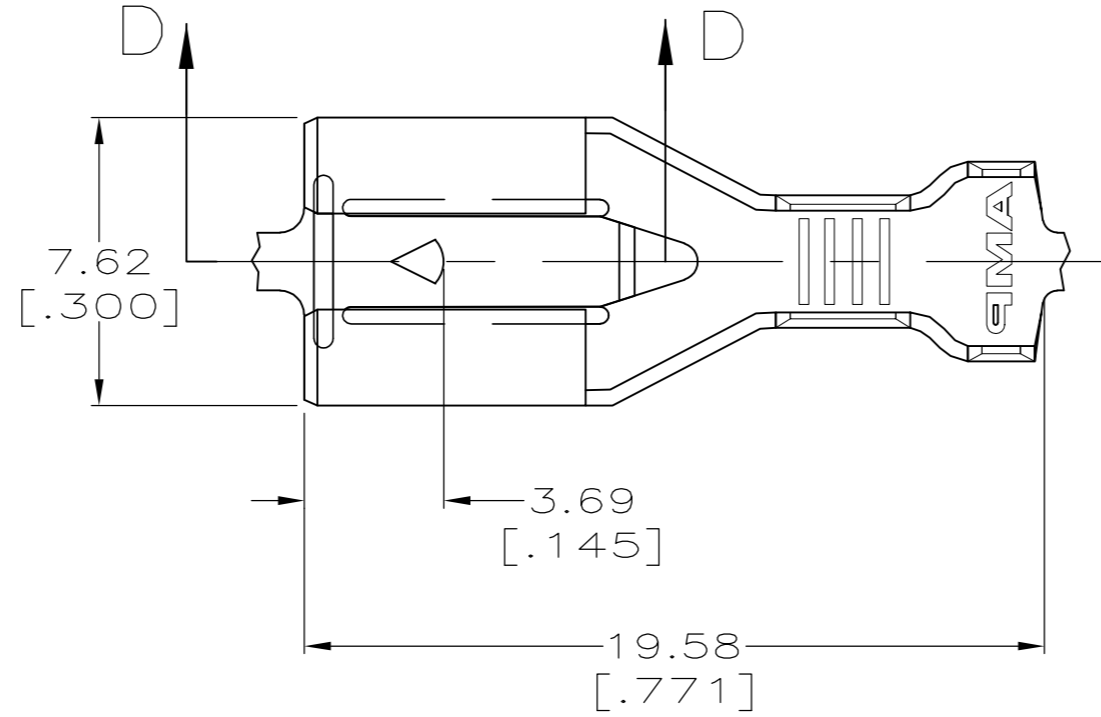

- 1 CONTINUOUS STRIP ON REELS.
- 2 STRESS RELIEVE PART, WILL HAVE HIGHER INSERTION FORCES.
- 3 PRELIMINARY - NOT FOR PRODUCTION

TIN 0.002032 [.000080] MIN	2.29-3.94 [.090-.155] DIA	[#18-#14] AWG	2 3 63854-3
TIN 0.002032 [.000080] MIN	2.29-3.94 [.090-.155] DIA	[#18-#14] AWG	63854-2
-	2.29-3.94 [.090-.155] DIA	[#18-#14] AWG	63854-1
FINISH	INSULATION RANGE	WIRE SIZE	PART NO

THIS DRAWING IS A CONTROLLED DOCUMENT.		DWN	JR RUTH	4/28/95	 TE Connectivity												
DIMENSIONS: INCHES		CHK	MS FEHER	4/28/95													
TOLERANCES UNLESS OTHERWISE SPECIFIED:		APVD	R REINER	4/28/95													
<table border="1"> <tr><td>0 PLC</td><td>± -</td></tr> <tr><td>1 PLC</td><td>± -</td></tr> <tr><td>2 PLC</td><td>± 0.25 [.010]</td></tr> <tr><td>3 PLC</td><td>± -</td></tr> <tr><td>4 PLC</td><td>± -</td></tr> <tr><td>ANGLES</td><td>± -</td></tr> </table>		0 PLC	± -	1 PLC		± -	2 PLC	± 0.25 [.010]	3 PLC	± -	4 PLC	± -	ANGLES	± -	PRODUCT SPEC	-	NAME
0 PLC	± -																
1 PLC	± -																
2 PLC	± 0.25 [.010]																
3 PLC	± -																
4 PLC	± -																
ANGLES	± -																
MATERIAL	H06 BRASS	FINISH	SEE TABLE	APPLICATION SPEC	114-2061												
CUSTOMER DRAWING		WEIGHT	-	SIZE	A2												
SCALE		5:1	SHEET	1 of 1	REV	L1											