

# H.I.D. lamps

# MASTER Colour CDM-TC



These are the most compact discharge lamps in the Mastercolour family, offering a sparkling light, a warm colour impression and an excellent colour rendering. Features of the CDM-TC /830, the smallest CDM-T lamp, include: stable colour over life, high efficiency, a CRI > 80, a long life compared to incandescent and halogen lamps, and a UV-block quartz outer bulb. CDM-TC have to be used with gear, preferably with the electronic PrimaVision gear, thus offering minimum system volume, flicker-free operation and optimal performance.

If conventional gear is used, a high-current or DC current protection device is mandatory, both for the ignitor and the ballast (conforming to IEC 1167). The lamps must be used in closed luminaires. For general lighting a hardened front glass is needed. Burning position: universal.

### Applications

- Accent lighting in shops

*Note: CDM-TC 70W is suited for operation with electronic gear having EOL protection.*

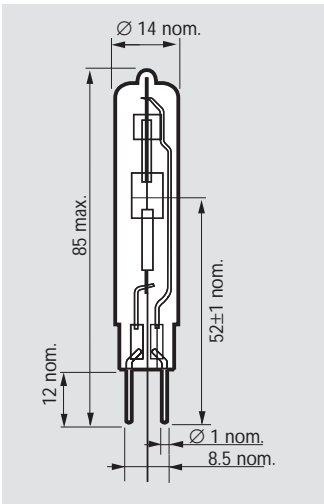

Dimensions in mm

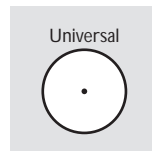

Burning position

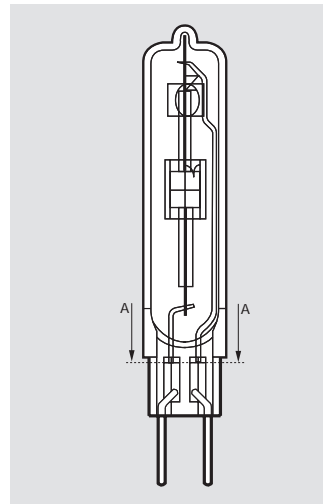

Detailed drawing

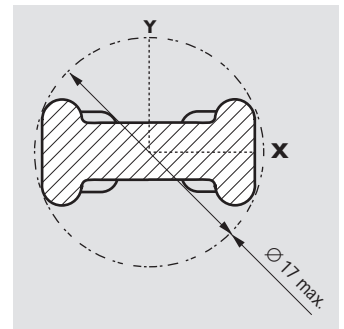

Cut-away A-A

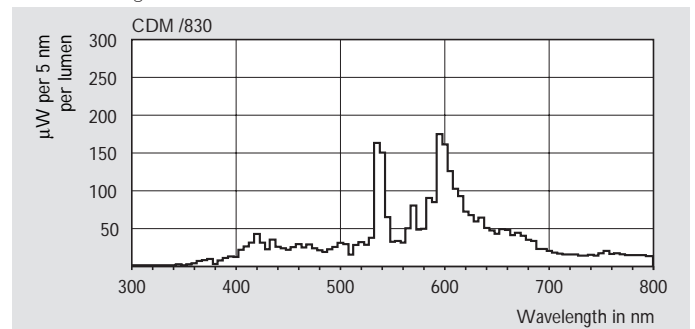

Spectral power distribution

Commercial name	Type	Wattage	Voltage	Lamp current	Lumen output	Correlated colour temperature	Chromaticity coordinate	Chromaticity coordinate	Colour rendering index
		W	V	A	lm	K	x	y	
MASTER Colour CDM-TC	CDM-TC 35W/830	38	88	0.5	3300	3000	432	394	81
MASTER Colour CDM-TC	CDM-TC 70W/830	71	83	1.0	6400	3000	439	398	83

Commercial name	Type	Wattage	Maximum lamp starting current	Efficacy of a source	P <sub>system</sub> conv. gear	P <sub>system</sub> electronic gear MHC	Run-up time	Maximum permissible bulb temperature	Maximum permissible base/pinch temperature	EOC
		W	A	lm/W	W	W	min.	°C	°C	
MASTER Colour CDM-TC	CDM-TC 35W/830	39	0.8	87	47	44	3	500	300	202277
MASTER Colour CDM-TC	CDM-TC 70W/830	71	1.4	90	88	-	3	500	300	201676

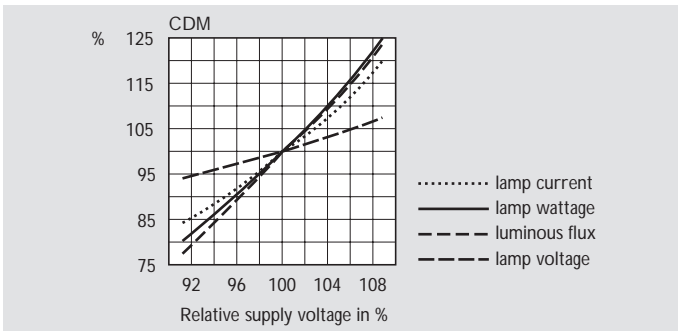

Effects of mains voltage variations

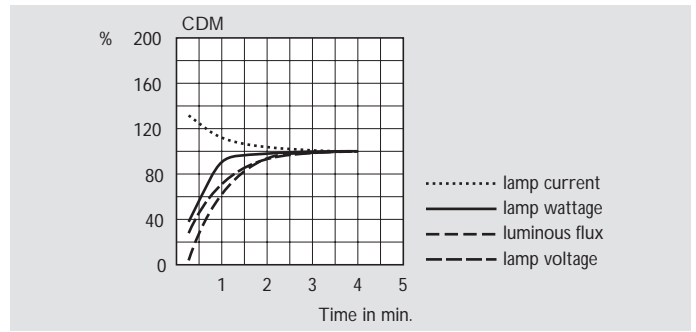

Lamp performances during run-up

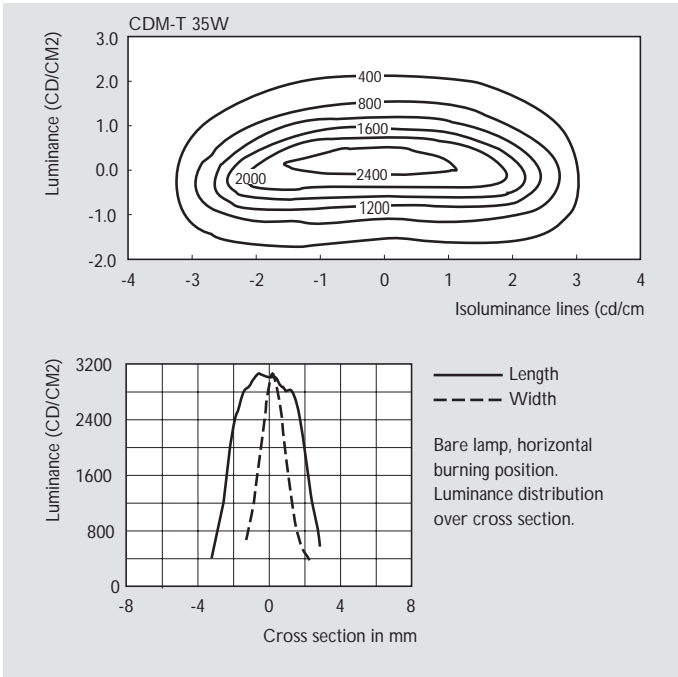

Luminance distribution

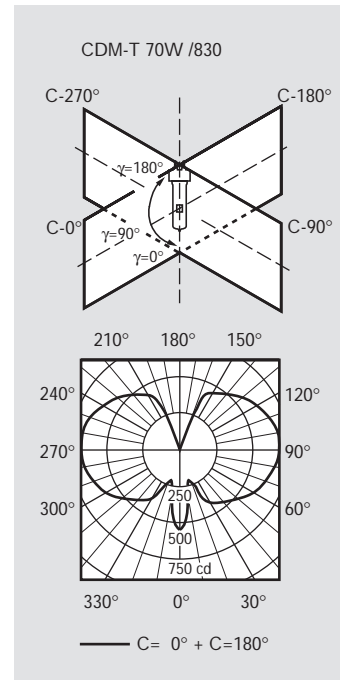
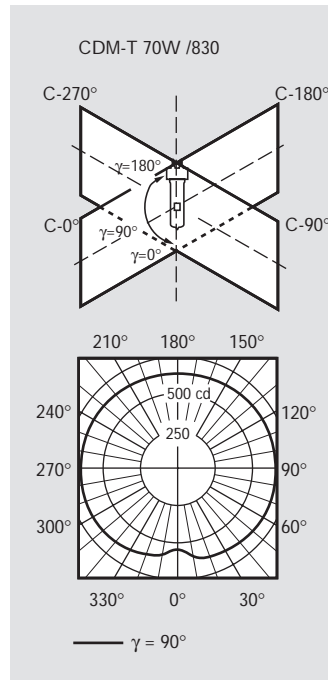
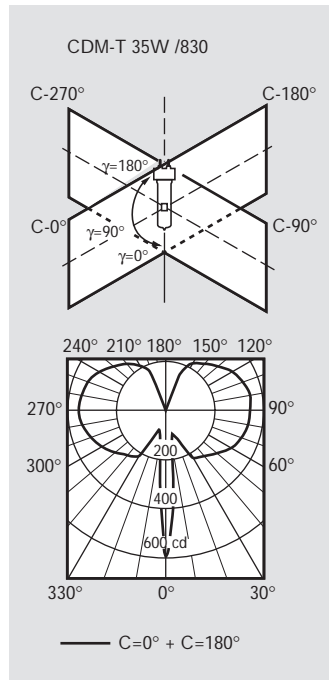
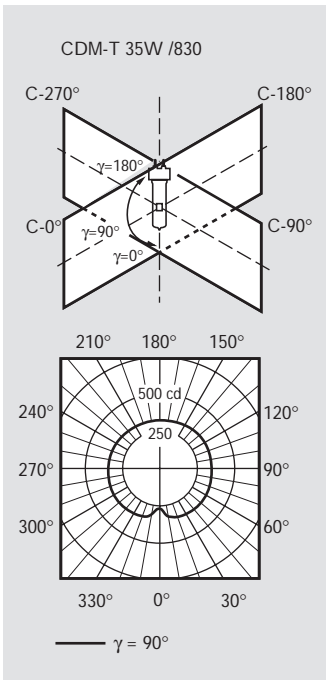

Polar light distributions