

1:6 LOW JITTER UNIVERSAL BUFFER/LEVEL TRANSLATOR WITH 2:1 INPUT MUX AND INDIVIDUAL OE (<1.25 GHz)

Features

- 6 differential or 12 LVCMOS outputs
- Ultra-low additive jitter: 100 fs rms
- Wide frequency range: 1 MHz to 1.25 GHz
- Any-format input with pin selectable output formats: LVPECL, Low Power LVPECL, LVDS, CML, HCSL, LVCMOS
- 2:1 mux with hot-swappable inputs
- Asynchronous output enable
- Individual output enable
- Low output-output skew: <50 ps
- Low propagation delay variation: <400 ps
- Independent V_{DD} and V_{DDO} : 1.8/2.5/3.3 V
- Excellent power supply noise rejection (PSRR)
- Selectable LVCMOS drive strength to tailor jitter and EMI performance
- Small size: 32-QFN (5x5 mm)
- RoHS compliant, Pb-free
- Industrial temperature range: -40 to +85 °C

Applications

- High-speed clock distribution
- Ethernet switch/router
- Optical Transport Network (OTN)
- SONET/SDH
- PCI Express Gen 1/2/3
- Storage
- Telecom
- Industrial
- Servers
- Backplane clock distribution

Description

The Si53314 is an ultra low jitter six output differential buffer with pin-selectable output clock signal format and individual OE. The Si53314 features a 2:1 mux, making it ideal for redundant clocking applications. The Si53314 utilizes Silicon Laboratories' advanced CMOS technology to fanout clocks from 1 MHz to 1.25 GHz with guaranteed low additive jitter, low skew, and low propagation delay variability. The Si53314 features minimal cross-talk and provides superior supply noise rejection, simplifying low jitter clock distribution in noisy environments. Independent core and output bank supply pins provide integrated level translation without the need for external circuitry.

Functional Block Diagram

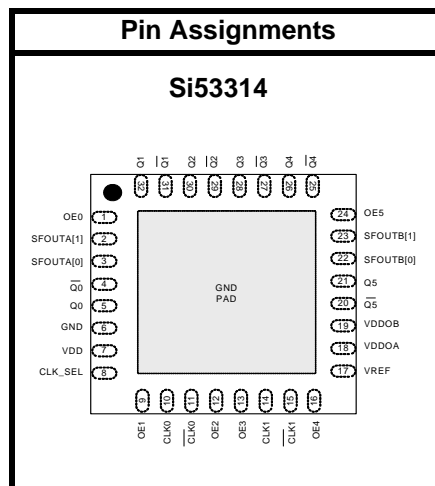
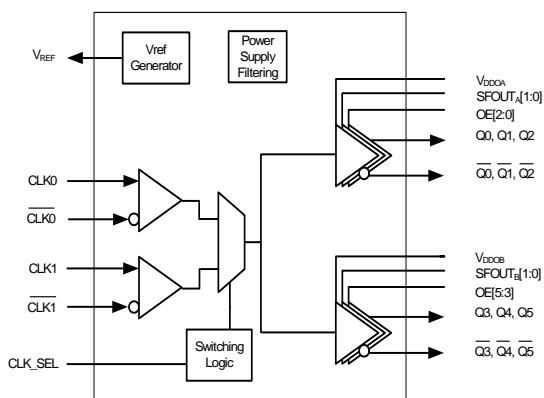

Patents pending

TABLE OF CONTENTS

<u>Section</u>	<u>Page</u>
1. Electrical Specifications	3
2. Functional Description	10
2.1. Universal, Any-Format Input	10
2.2. Input Bias Resistors	12
2.3. Universal, Any-Format Output Buffer	12
2.4. Input Mux and Output Enable Logic	13
2.5. Power Supply (V_{DD} and V_{DDOX})	13
2.6. Output Clock Termination Options	14
2.7. AC Timing Waveforms	17
2.8. Typical Phase Noise Performance	18
2.9. Input Mux Noise Isolation	19
2.10. Power Supply Noise Rejection	20
3. Pin Description: 32-Pin QFN	21
4. Ordering Guide	24
5. Package Outline	25
5.1. 5x5 mm 32-QFN Package Diagram	25
6. PCB Land Pattern	26
6.1. 5x5 mm 32-QFN Package Land Pattern	26
7. Top Marking	27
7.1. Si53314 Top Marking	27
7.2. Top Marking Explanation	27
Contact Information	28

1. Electrical Specifications

Table 1. Recommended Operating Conditions

Parameter	Symbol	Test Condition	Min	Typ	Max	Unit
Ambient Operating Temperature	T_A		-40	—	85	°C
Supply Voltage Range*	V_{DD}	LVDS, CML, HCSL, LVCMOS	1.71	1.8	1.89	V
		LVPECL, low power LVPECL, LVDS, CML, HCSL, LVCMOS	2.38	2.5	2.63	V
			2.97	3.3	3.63	V
Output Buffer Supply Voltage*	V_{DDO}	LVDS, CML, HCSL, LVCMOS	1.71	—	1.89	V
		LVPECL, low power LVPECL, LVDS, CML, HCSL, LVCMOS	2.38	—	2.63	V
			2.97	—	3.63	V

*Note: Core supply V_{DD} and output buffer supplies V_{DDO} are independent.

Table 2. Input Clock Specifications

($V_{DD} = 1.8\text{ V} \pm 5\%$, $2.5\text{ V} \pm 5\%$, or $3.3\text{ V} \pm 10\%$, $T_A = -40$ to $85\text{ }^\circ\text{C}$)

Parameter	Symbol	Test Condition	Min	Typ	Max	Unit
Differential Input Common Mode Voltage	V_{CM}	$V_{DD} = 2.5\text{ V} \pm 5\%$, $3.3\text{ V} \pm 10\%$	0.05	—	—	V
Input Swing (single-ended, peak-to-peak)	V_{IN}		0.1	—	1.1	V
Input Voltage High	V_{IH}		$V_{DD} \times 0.7$	—	—	V
Input Voltage Low	V_{IL}		—	—	$V_{DD} \times 0.3$	V
Input Capacitance	C_{IN}		—	5	—	pF

Table 3. DC Common Characteristics

($V_{DD} = 1.8\text{ V} \pm 5\%$, $2.5\text{ V} \pm 5\%$, or $3.3\text{ V} \pm 10\%$, $T_A = -40\text{ to }85\text{ }^\circ\text{C}$)

Parameter	Symbol	Test Condition	Min	Typ	Max	Unit
Supply Current	I_{DD}		—	TBD	100	mA
Output Buffer Supply Current (Per Clock Output) @100 MHz	I_{DDOX}	LVPECL (3.3 V)	—	35	—	mA
		Low Power LVPECL (3.3 V)	—	30	—	mA
		LVDS (3.3 V)	—	20	—	mA
		CML (3.3 V)	—	30	—	mA
		HCSL, 100 MHz, 2 pF load (3.3 V)	—	35	—	mA
		CMOS (1.8 V, SFOUT = Open/0), per output, $C_L = 5\text{ pF}$, 200 MHz	—	5	—	mA
		CMOS (2.5 V, SFOUT = Open/0), per output, $C_L = 5\text{ pF}$, 200 MHz	—	8	—	mA
Leakage Current	I_L	Input leakage at all inputs except CLKIN, $V_{IN} = 0\text{ V}$	—	—	TBD	μA
		Input leakage at CLKIN $V_{IN} = 0\text{ V}$	—	—	TBD	μA
Voltage Reference	V_{REF}	V_{REF} pin	—	$V_{DD}/2$	—	V
Input High Voltage	V_{IH}	SFOUTX, DIVX 3-level input pins	$0.85 \times V_{DD}$	—	—	V
Input Mid Voltage	V_{IM}	SFOUTX, DIVX 3-level input pins	$0.45 \times V_{DD}$	$0.5 \times V_{DD}$	$0.55 \times V_{DD}$	V
Input Low Voltage	V_{IL}	SFOUTX, DIVXpin 3-level input pins	—	—	$0.15 \times V_{DD}$	V
Internal Pull-down Resistor	R_{DOWN}	CLK_SEL, DIVA, DIVB, SFOUTA[1], SFOUTB[1]	—	25	—	k Ω
Internal Pull-up Resistor	R_{UP}	SFOUTA[1], SFOUTB[1], DIVA, DIVB, OEX, OEX	—	25	—	k Ω

Table 4. DC Characteristics—LVPECL and Low Power LVPECL $(V_{DD} = 2.5\text{ V} \pm 5\%$, or $3.3\text{ V} \pm 10\%$, $T_A = -40$ to $85\text{ }^\circ\text{C}$)

Parameter	Symbol	Test Condition	Min	Typ	Max	Unit
Output Voltage High	V_{OH}	$R_L = 50\ \Omega$ to $V_{DDOX} - 2\text{ V}$	$V_{DDOX} - 1.145$	—	$V_{DDOX} - 0.895$	V
Output Voltage Low	V_{OL}	$R_L = 50\ \Omega$ to $V_{DDOX} - 2\text{ V}$	$V_{DDOX} - 1.945$	—	$V_{DDOX} - 1.695$	V
Output DC Common Mode Voltage	V_{COM}		$V_{DDOX} - 1.895$	—	$V_{DDOX} - 1.425$	V
Single-Ended Output Swing	V_{SE}	Terminate unused outputs to $R_L = 50\ \Omega$ to $V_{DDOX} - 2\text{ V}$	0.25	0.60	0.85	V

Table 5. DC Characteristics—CML $(V_{DD} = 1.8\text{ V} \pm 5\%$, $2.5\text{ V} \pm 5\%$, or $3.3\text{ V} \pm 10\%$, $T_A = -40$ to $85\text{ }^\circ\text{C}$)

Parameter	Symbol	Test Condition	Min	Typ	Max	Unit
Single-Ended Output Swing	V_{SE}	Terminated as shown in Figure 6 (CML termination).	300	400	500	mV

Table 6. DC Characteristics—LVDS $(V_{DD} = 1.8\text{ V} \pm 5\%$, $2.5\text{ V} \pm 5\%$, or $3.3\text{ V} \pm 10\%$, $T_A = -40$ to $85\text{ }^\circ\text{C}$)

Parameter	Symbol	Test Condition	Min	Typ	Max	Unit
Single-Ended Output Swing	V_{SE}	$R_L = 100\ \Omega$ across Q_N and \overline{Q}_N	247	—	454	mV
Output Common Mode Voltage ($V_{DDO} = 2.5\text{ V}$ or 3.3 V)	V_{COM1}	$V_{DDOX} = 2.38$ to 2.63 V , 2.97 to 3.63 V , $R_L = 100\ \Omega$ across Q_N and \overline{Q}_N	1.10	1.25	1.35	V
Output Common Mode Voltage ($V_{DDO} = 1.8\text{ V}$)	V_{COM2}	$V_{DDOX} = 1.71$ to 1.89 V , $R_L = 100\ \Omega$ across Q_N and \overline{Q}_N	0.85	0.97	1.10	V

Table 7. DC Characteristics—LVCMOS

($V_{DD} = 1.8\text{ V} \pm 5\%$, $2.5\text{ V} \pm 5\%$, or $3.3\text{ V} \pm 10\%$, $T_A = -40\text{ to }85\text{ }^\circ\text{C}$)

Parameter	Symbol	Test Condition	Min	Typ	Max	Unit
Output Voltage High*	V_{OH}		$0.8 \times V_{DDOX}$	—	—	V
Output Voltage Low*	V_{OL}		—	—	$0.2 \times V_{DDOX}$	V

*Note: I_{OH} and I_{OL} per the Output Signal Format Table for specific V_{DDOX} and SFOUTX settings.

Table 8. DC Characteristics—HCSL

($V_{DD} = 1.8\text{ V} \pm 5\%$, $2.5\text{ V} \pm 5\%$, or $3.3\text{ V} \pm 10\%$, $T_A = -40\text{ to }85\text{ }^\circ\text{C}$)

Parameter	Symbol	Test Condition	Min	Typ	Max	Unit
Output Voltage High	V_{OH}	$R_L = 50\ \Omega$ to GND	550	700	850	mV
Output Voltage Low	V_{OL}	$R_L = 50\ \Omega$ to GND	-150	0	150	mV
Single-Ended Output Swing	V_{SE}	$R_L = 50\ \Omega$ to GND	—	700	—	mV
Crossing Voltage	V_C	$R_L = 50\ \Omega$ to GND	250	350	550	mV

Table 9. AC Characteristics $(V_{DD} = 1.8\text{ V} \pm 5\%, 2.5\text{ V} \pm 5\%, \text{ or } 3.3\text{ V} \pm 10\%, T_A = -40 \text{ to } 85\text{ }^\circ\text{C})$

Parameter	Symbol	Test Condition	Min	Typ	Max	Unit
Frequency	F	LVPECL, low power LVPECL, LVDS, CML, HCSL	1	—	1250	MHz
		LVC MOS	1	—	200	MHz
Duty Cycle Note: 50% input duty cycle.	D_C	200 MHz, 50 Ω to $V_{DD}/2$, 20/80% $T_R/T_F < 10\%$ of period (LVC MOS)	TBD	TBD	TBD	%
		20/80% $T_R/T_F < 10\%$ of period (Differential)	48	50	52	%
Minimum Input Clock Slew Rate ¹	SR	Required to meet prop delay and additive jitter specifications (20–80%)	0.75	—	—	V/ns
Output Rise/Fall Time	T_R/T_F	LVPECL, LVDS, CML, HCSL, 20/80%			350	ps
		200 MHz, 50 Ω , 20/80%, 2 pF load (LVC MOS)	TBD	TBD	750	ps
Minimum Input Pulse Width	T_W		500	—	—	ps
Additive Jitter (Differential Clock Input)	J	$V_{DD} = 2.5/3.3\text{ V}$, LVPECL/LVDS, $F = 725\text{ MHz}$, 0.75 V/ns input slew rate	—	60	80	fs
Propagation Delay	T_{PLH} , T_{PHL}	Low to high, high to low Single-ended	TBD	—	TBD	ns
		Low to high, high to low Differential	TBD	—	TBD	ns
Output Enable Time ²	T_{EN}	F = 1 MHz	—	2	—	μs
		F = 100 MHz	—	60	—	ns
		F = 725 MHz	—	50	—	ns
Output Disable Time ²	T_{DIS}	F = 1 MHz	—	2	—	μs
		F = 100 MHz	—	25	—	ns
		F = 725 MHz	—	15	—	ns

Notes:

1. For clock division applications, a minimum input clock slew rate of 30 mV/ns is required.
2. See Figure 4.
3. Defined as skew between outputs on different devices operating at the same supply voltages, temperatures, and equal load conditions. Using the same type of inputs on each device, the outputs are measured at the differential cross points.
4. Measured for 156.25 MHz carrier frequency. Sine-wave noise added to V_{DDOX} (1.8 V = 50 mV_{PP}, 2.5/3.3 V = 100 mV_{PP}) and noise spur amplitude measured. See AN491 for further details.

Table 9. AC Characteristics (Continued)

($V_{DD} = 1.8\text{ V} \pm 5\%$, $2.5\text{ V} \pm 5\%$, or $3.3\text{ V} \pm 10\%$, $T_A = -40\text{ to }85\text{ }^\circ\text{C}$)

Parameter	Symbol	Test Condition	Min	Typ	Max	Unit
Output to Output Skew	T_{SK}	Identical Configuration, Single-ended (Q_N to Q_M)	—	—	100	ps
		Identical Configuration, Differential (Q_N to Q_M)	—	—	50	ps
Part to Part Skew ³	T_{PS}	Identical configuration	—	50	—	ps
Power Supply Noise Rejection ⁴	PSRR	10 kHz sinusoidal noise	—	-90	—	dBc
		100 kHz sinusoidal noise	—	-90	—	dBc
		500 kHz sinusoidal noise	—	-80	—	dBc
		1 MHz sinusoidal noise	—	-70	—	dBc

Notes:

1. For clock division applications, a minimum input clock slew rate of 30 mV/ns is required.
2. See Figure 4.
3. Defined as skew between outputs on different devices operating at the same supply voltages, temperatures, and equal load conditions. Using the same type of inputs on each device, the outputs are measured at the differential cross points.
4. Measured for 156.25 MHz carrier frequency. Sine-wave noise added to V_{DDOX} ($1.8\text{ V} = 50\text{ mV}_{PP}$, $2.5/3.3\text{ V} = 100\text{ mV}_{PP}$) and noise spur amplitude measured. See AN491 for further details.

Table 10. Thermal Conditions

Parameter	Symbol	Test Condition	Value	Unit
Thermal Resistance, Junction to Ambient	θ_{JA}	Still air	49.6	°C/W
Thermal Resistance, Junction to Case	θ_{JC}	Still air	32.3	°C/W

Table 11. Absolute Maximum Ratings

Parameter	Symbol	Test Condition	Min	Typ	Max	Unit
Storage Temperature	T_S		-55	—	150	°C
Supply Voltage	V_{DD}		-0.5	—	3.8	V
Input Voltage	V_{IN}		-0.5	—	$V_{DD} + 0.3$	V
Output Voltage	V_{OUT}	s	—	—	$V_{DD} + 0.3$	V
ESD Sensitivity	HBM	HBM, 100 pF, 1.5 k Ω	2000	—	—	V
ESD Sensitivity	CDM		500	—	—	V
Peak Soldering Reflow Temperature	T_{PEAK}	Pb-Free; Solder reflow profile per JEDEC J-STD-020	—	—	260	°C
Maximum Junction Temperature	T_J		—	—	125	°C
Note: Stresses beyond those listed in this table may cause permanent damage to the device. Functional operation specification compliance is not implied at these conditions. Exposure to maximum rating conditions for extended periods may affect device reliability.						

2. Functional Description

The Si53314 is a low jitter, low skew 1:6 differential buffer with an integrated 2:1 input mux and individual OE control. The device has a universal input that accepts most common differential or LVCMOS input signals. A clock select pin control is used to select the active input clock. The selected clock input is routed to two independent banks of outputs. Each output bank features control pins to select signal format setting and LVCMOS drive strength. In addition, each clock output has an independent OE pin for individual clock enable/disable.

2.1. Universal, Any-Format Input

The Si53314 has a universal input stage that enables simple interfacing to a wide variety of clock formats, including LVPECL, LVCMOS, LVDS, HCSL, and CML. Tables 12 and 13 summarize the various input ac- and dc-coupling options supported by the device. Figures 1 and 2 show the recommended input clock termination options.

Table 12. LVPECL, LVCMOS, and LVDS

	LVPECL		LVCMOS		LVDS	
	AC-Couple	DC-Couple	AC-Couple	DC-Couple	AC-Couple	DC-Couple
1.8 V	N/A	N/A	No	Yes	Yes	No
2.5/3.3 V	Yes	Yes	No	Yes	Yes	Yes

Table 13. HCSL and CML

	HCSL		CML	
	AC-Couple	DC-Couple	AC-Couple	DC-Couple
1.8 V	No	No	Yes	No
2.5/3.3 V	No	Yes (3.3 V)	Yes	No

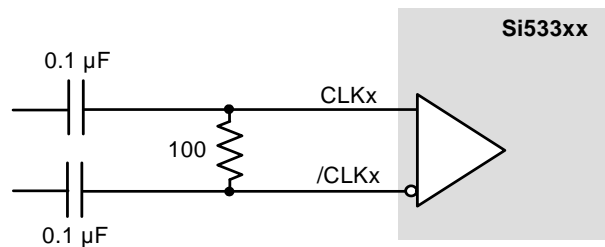

Figure 1. Differential LVPECL, LVDS, CML AC-Coupled Input Termination

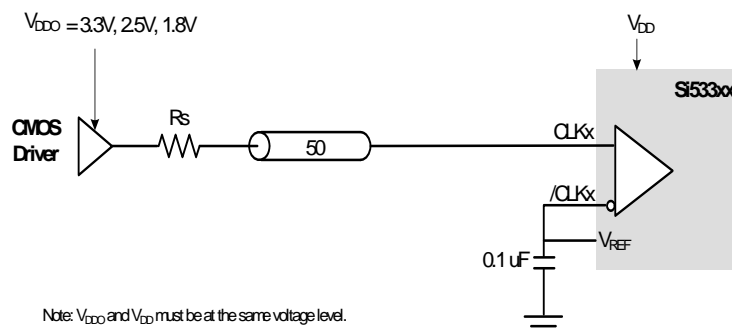
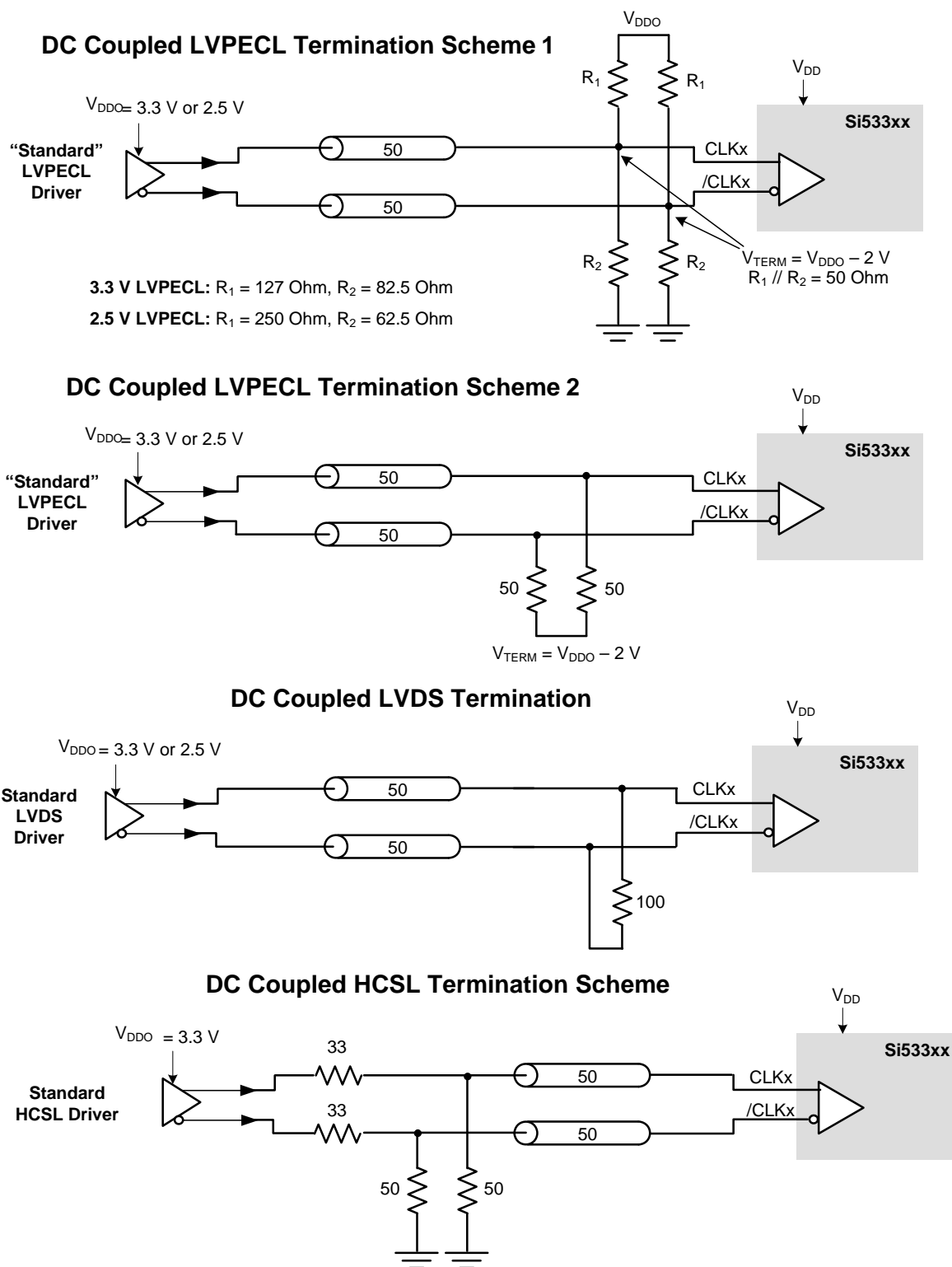

Figure 2. LVCMOS DC-Coupled Input Termination



Note: 33 Ohm series termination is optional depending on the location of the receiver.

Figure 3. Differential DC-Coupled Input Terminations

2.2. Input Bias Resistors

Internal bias resistors ensure a differential output low condition in the event that the clock inputs are not connected. The noninverting input is biased with a 18.75 kΩ pullup to V_{DD} and a 75 kΩ pullup to V_{DD}. The inverting input is biased with a 75 kΩ pullup to V_{DD} and a 18.75 kΩ pullup to GND.

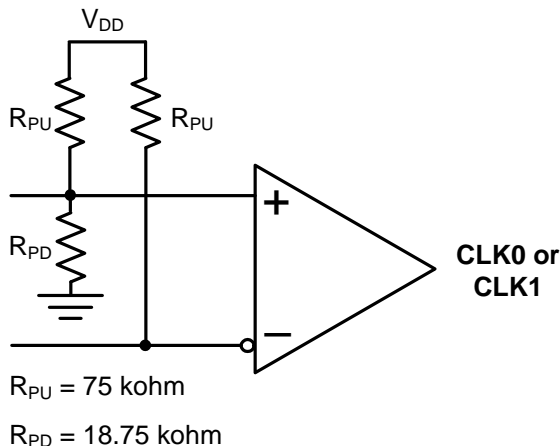

Figure 4. Input Bias Resistors

2.3. Universal, Any-Format Output Buffer

The Si53314 has highly flexible output drivers that support a wide range of clock signal formats, including LVPECL, low power LVPECL, LVDS, CML, HCSL, and LVCMOS. SFOUTX[1] and SFOUTX[0] are 3-level inputs that can be pin-strapped to select the clock signal formats for all of the outputs, Q0 through Q5. This feature enables the device to be used for format/level translation in addition to clock distribution, minimizing the number of unique buffer part numbers required in a typical application and simplifying design reuse. For EMI reduction applications, four LVCMOS drive strength options are available for each V_{DDO} setting.

Table 14. Output Signal Format Selection

SFOUTX[1]	SFOUTX[0]	V _{DDOX} = 3.3 V	V _{DDOX} = 2.5 V	V _{DDOX} = 1.8 V
Open*	Open*	LVPECL	LVPECL	N/A
0	0	LVDS	LVDS	LVDS
0	1	LVCMOS, 24 mA drive	LVCMOS, 18 mA drive	LVCMOS, 12 mA drive
1	0	LVCMOS, 18 mA drive	LVCMOS, 12 mA drive	LVCMOS, 9 mA drive
1	1	LVCMOS, 12 mA drive	LVCMOS, 9 mA drive	LVCMOS, 6 mA drive
Open*	0	LVCMOS, 6 mA drive	LVCMOS, 4 mA drive	LVCMOS, 2 mA drive
Open*	1	LVPECL Low power	LVPECL Low power	N/A
0	Open*	CML	CML	CML
1	Open*	HCSL	HCSL	HCSL

***Note:** SFOUTX[1:0] are 3-level input pins. Tie low for “0” setting. Tie high for “1” setting. When left open, the pin floats to V_{DD}/2.

2.4. Input Mux and Output Enable Logic

The Si53314 provides two clock inputs for applications that need to select between one of two clock sources. The CLK_SEL pin selects the active clock input. The table below summarizes the input and output clock based on the input mux and output enable pin settings.

Table 15. Input Mux and Output Enable Logic

CLK_SEL	CLK0	CLK1	OEx ¹	Qx ²
L	L	X	H	L
L	H	X	H	H
H	X	L	H	L
H	X	H	H	H
X	X	X	L	L ³

Notes:

1. Output enable active high
2. On the next negative transition of CLK0 or CLK1.
3. Single-end: Qx = low, \overline{Qx} = high
Differential: Qx = low, Qx = high

2.5. Power Supply (V_{DD} and V_{DDOX})

The device includes separate core (V_{DD}) and output driver supplies (V_{DDOX}). This feature allows the core to operate at a lower voltage than V_{DDO} , reducing current consumption in mixed supply applications. The core V_{DD} supports 3.3, 2.5, or 1.8 V. Each output bank has its own V_{DDOX} supply, supporting 3.3, 2.5, or 1.8 V.

2.6. Output Clock Termination Options

The recommended output clock termination options are shown below. Unused output clocks should be left floating.

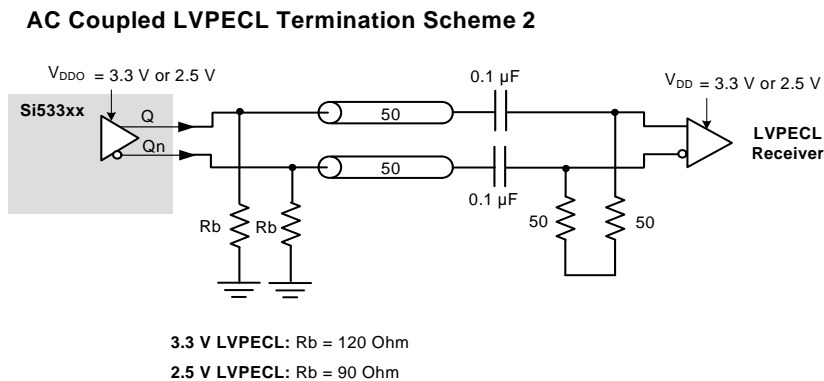
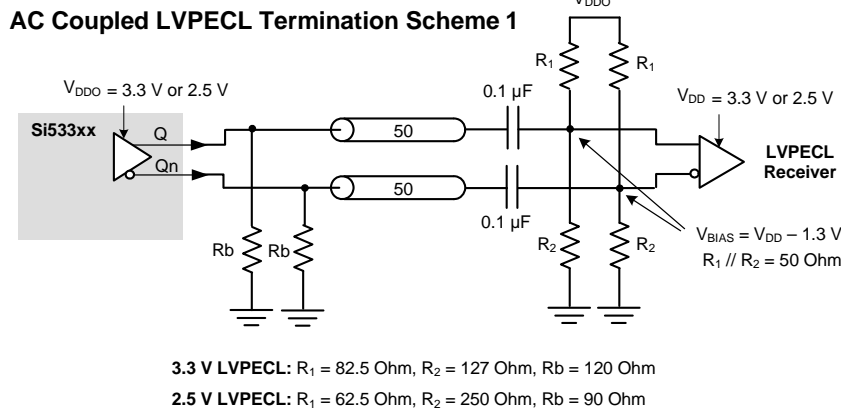
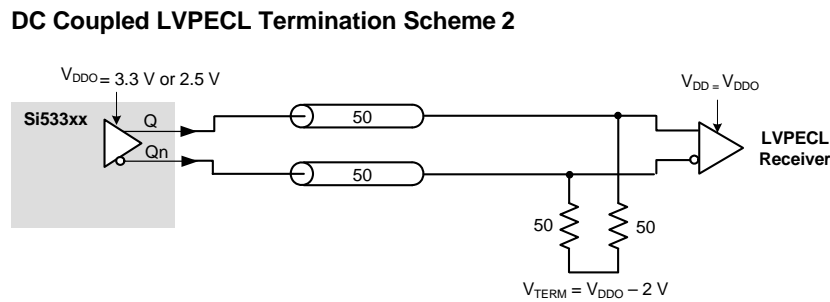
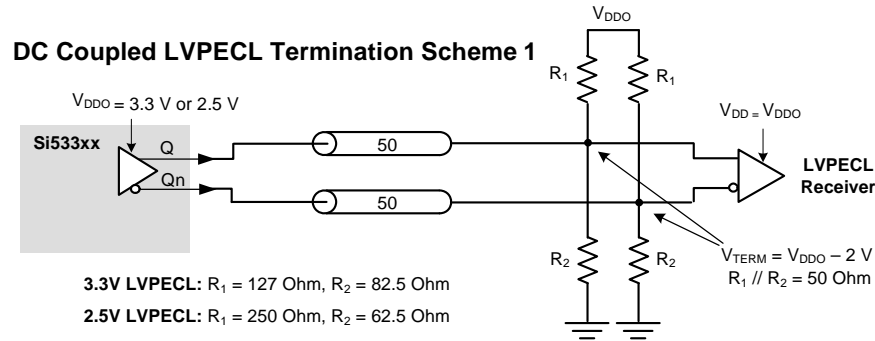

Figure 5. LVPECL Output Termination

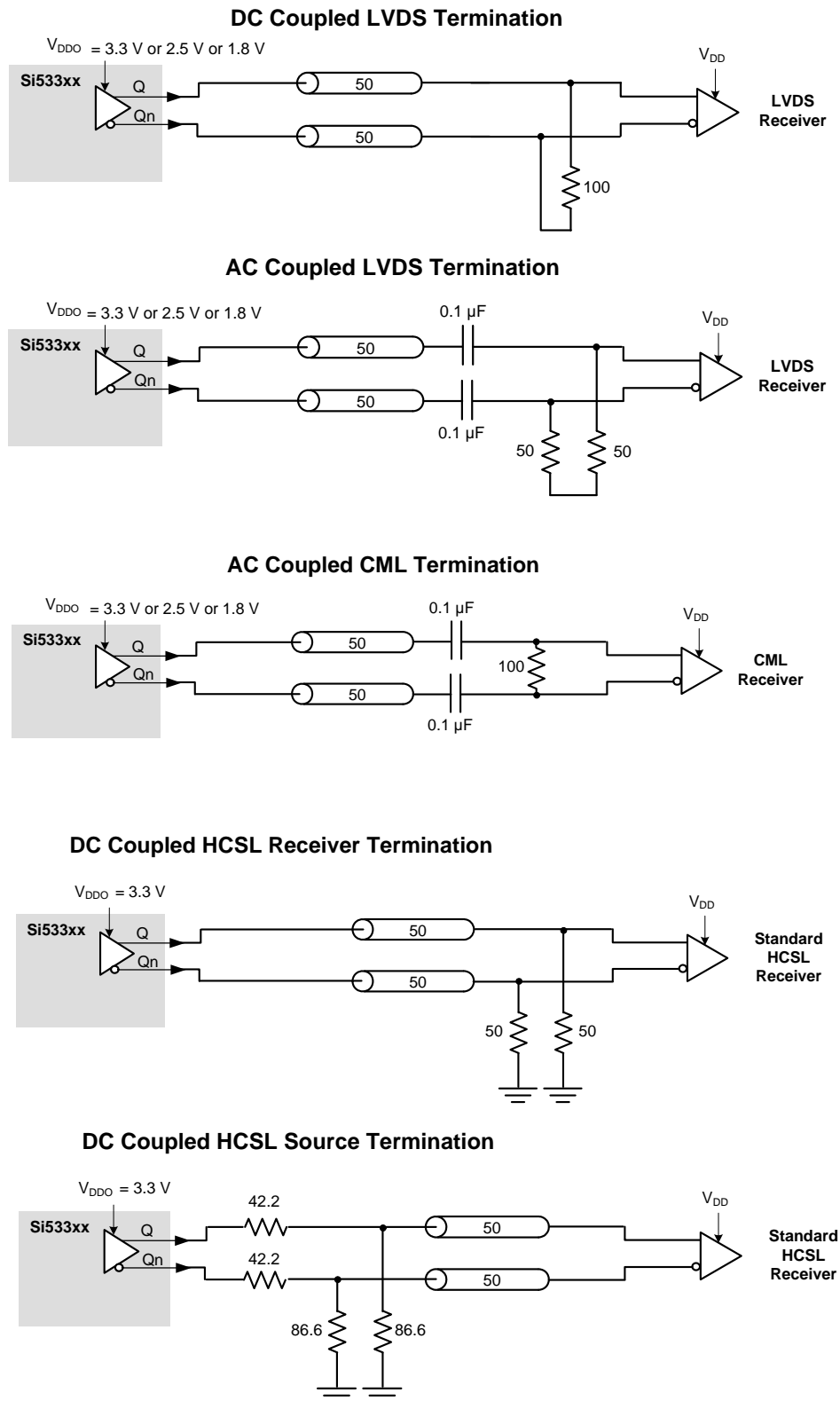

Figure 6. LVDS, CML, and HCSSL Output Termination

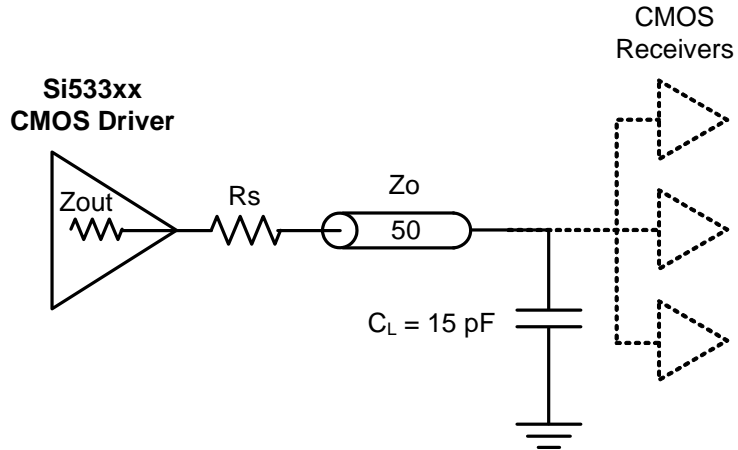

Figure 7. LVC MOS Output Termination

Table 16. Recommended LVC MOS R_S Series Termination

SFOUTX[1]	SFOUTX[0]	R_S (ohms)		
		3.3 V	2.5 V	1.8 V
0	1	33	33	33
1	0	33	33	33
1	1	0	0	0
Open	0	0	0	0

2.7. AC Timing Waveforms

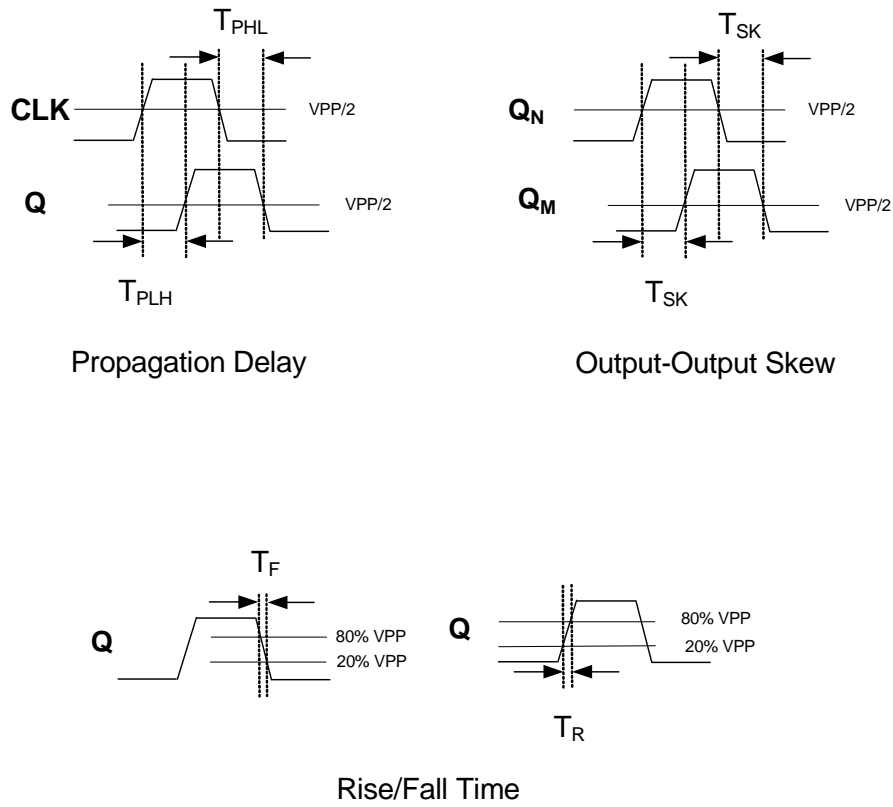
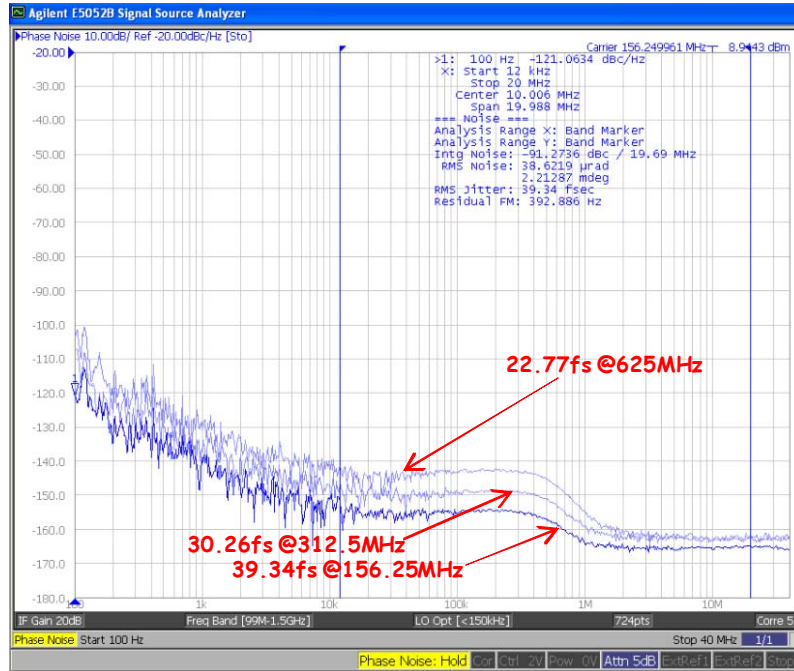
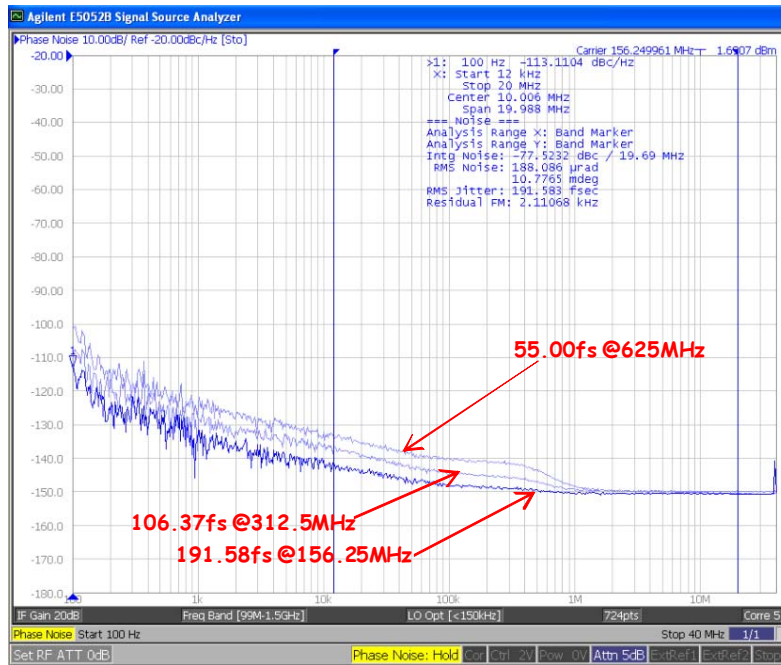

Figure 8. AC Waveforms

2.8. Typical Phase Noise Performance



Source Jitter



Total Jitter

Figure 9. Si53314 Phase Noise

Note: Measured single-endedly.

Table 17. Si53314 Additive Jitter

Frequency (MHz)	Source Jitter (fs)	Total Jitter (fs)	Additive Jitter (fs)
156.25	39.34	191.58	187.50
312.5	30.26	106.37	101.98
625	22.77	55.00	50.07

2.9. Input Mux Noise Isolation

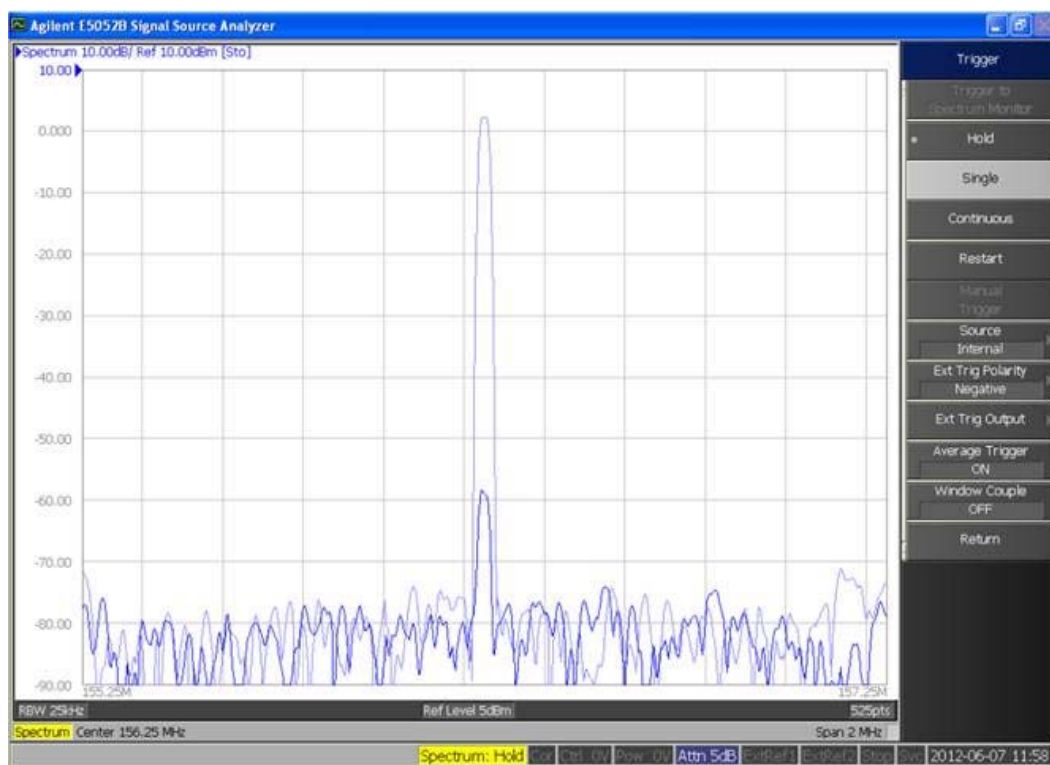

Figure 10. Input Mux Noise Isolation

2.10. Power Supply Noise Rejection

The device supports on-chip supply voltage regulation to reject noise present on the power supply, simplifying low jitter operation in real-world environments. This feature enables robust operation alongside FPGAs, ASICs and SoCs and may reduce board-level filtering requirements. For more information, see “AN491: Power Supply Rejection for Low Jitter Clocks”.

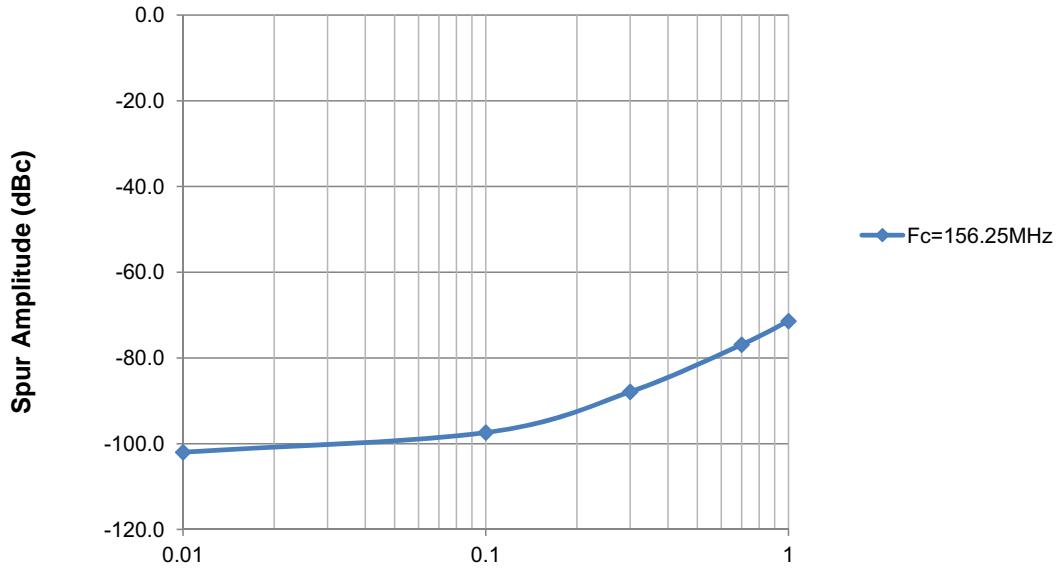

Figure 11. Power Supply Noise Rejection (100 mVpp Sinusoidal Power Supply Noise Applied)

3. Pin Description: 32-Pin QFN

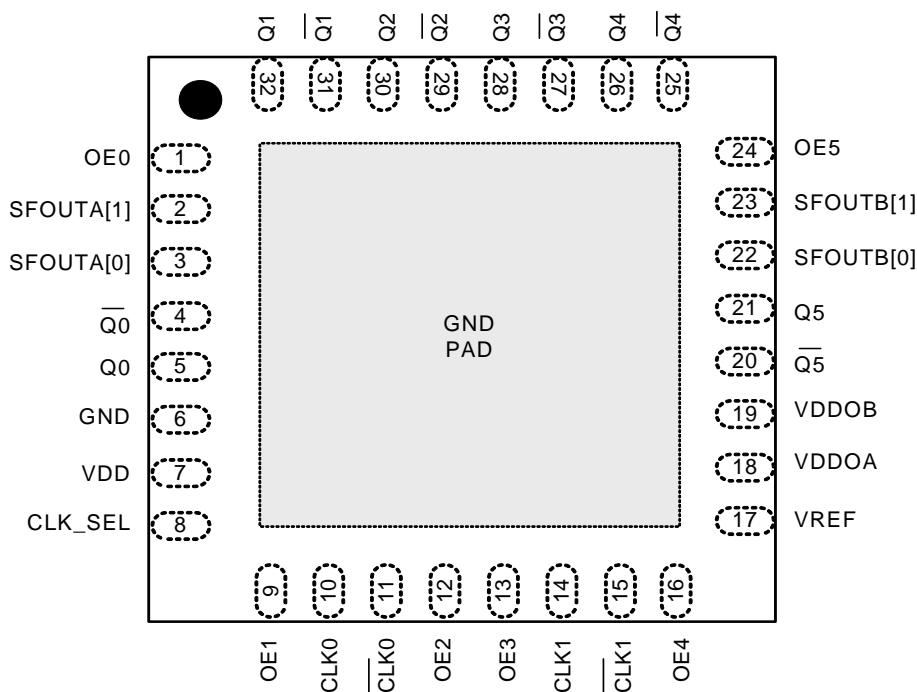

Table 18. Pin Description

Pin	Name	Description
1	OE0	Output enable—Output 0 When OE = high, the Q0 is enabled. When OE = low, Q is held low and \bar{Q} is held high for differential formats. For LVCMOS, both Q and \bar{Q} are held low when OE is set low. This pin contains an internal pull-up resistor.
2	SFOUTA[1]	Output signal format control pin for Bank A Three level input control. Internally biased at $V_{DD}/2$. Can be left floating or tied to ground or V_{DD} .
3	SFOUTA[0]	Output signal format control pin for Bank A Three level input control. Internally biased at $V_{DD}/2$. Can be left floating or tied to ground or V_{DD} .
4	$\bar{Q}0$	Output clock 0 (complement)
5	Q0	Output clock 0
6	GND	Ground
7	V_{DD}	Core voltage supply Bypass with 1.0 μF capacitor and place as close to the V_{DD} pin as possible.

Table 18. Pin Description (Continued)

Pin	Name	Description
8	CLK_SEL	Mux input select pin (LVCMOS) When CLK_SEL is high, CLK1 is selected. When CLK_SEL is low, CLK0 is selected. CLK_SEL contains an internal pull-down resistor.
9	OE1	Output enable—Output 1 When OE = high, the Q1 is enabled. When OE = low, Q is held low and \bar{Q} is held high for differential formats. For LVCMOS, both Q and \bar{Q} are held low when OE is set low. This pin contains an internal pull-up resistor.
10	CLK0	Input clock 0
11	$\overline{\text{CLK0}}$	Input clock 0 (complement) When the CLK0 is driven by a single-end input, connect V_{REF} to $\overline{\text{CLK0}}$. CLK0 contains an internal pull-up resistor.
12	OE2	Output enable—Output 2 When OE = high, the Q2 is enabled. When OE = low, Q is held low and \bar{Q} is held high for differential formats. For LVCMOS, both Q and \bar{Q} are held low when OE is set low. OE2 contains an internal pull-up resistor.
13	OE3	Output enable—Output 3 When OE = high, the Q3 is enabled. When OE = low, Q is held low and \bar{Q} is held high for differential formats. For LVCMOS, both Q and \bar{Q} are held low when OE is set low. OE3 contains an internal pull-up resistor.
14	CLK1	Input clock 1
15	$\overline{\text{CLK1}}$	Input clock 1 (complement) When the CLK1 is driven by a single-end input, connect V_{REF} to $\overline{\text{CLK1}}$. CLK1 contains an internal pull-up resistor.
16	OE4	Output enable—Output 4 When OE = high, the Q4 is enabled. When OE = low, Q is held low and \bar{Q} is held high for differential formats. For LVCMOS, both Q and \bar{Q} are held low when OE is set low. This pin contains an internal pull-up resistor.
17	V_{REF}	Input reference voltage When driven by a LVCMOS clock input, connect the unused clock input to V_{REF} and a 0.1 μF cap to ground. When driven by a differential clock, do not connect the V_{REF} pin.
18	V_{DDOA}	Output voltage supply—Bank A (Outputs: Q0 to Q2) Bypass with 1.0 μF capacitor and place as close to the V_{DDOA} pin as possible.

Table 18. Pin Description (Continued)

Pin	Name	Description
19	V _{DDOB}	Output voltage supply—Bank B (Outputs: Q3 to Q5) Bypass with 1.0 μ F capacitor and place as close to the V _{DDOB} pin as possible.
20	$\overline{Q5}$	Output clock 5 (complement)
21	Q5	Output clock 5
22	SFOUTB[0]	Output signal format control pin for Bank B Three level input control. Internally biased at V _{DD} /2. Can be left floating or tied to ground or V _{DD} .
23	SFOUTB[1]	Output signal format control pin for Bank B Three level input control. Internally biased at V _{DD} /2. Can be left floating or tied to ground or V _{DD} .
24	OE5	Output enable—Output 5 When OE = high, the Q5 is enabled. When OE = low, Q is held low and \overline{Q} is held high for differential formats. For LVCMOS, both Q and \overline{Q} are held low when OE is set low. This pin contains an internal pull-up resistor.
25	$\overline{Q4}$	Output clock 4 (complement)
26	Q4	Output clock 4
27	$\overline{Q3}$	Output clock 3 (complement)
28	Q3	Output clock 3
29	$\overline{Q2}$	Output clock 2 (complement)
30	Q2	Output clock 2
31	$\overline{Q1}$	Output clock 1 (complement)
32	Q1	Output clock 1
GND Pad	GND	Ground Pad Power supply ground and thermal relief.

Si53314

4. Ordering Guide

Part Number	Package	PB-Free, ROHS-6	Temperature
Si53314-B-GM	32-QFN	Yes	-40 to 85 °C

5. Package Outline

5.1. 5x5 mm 32-QFN Package Diagram

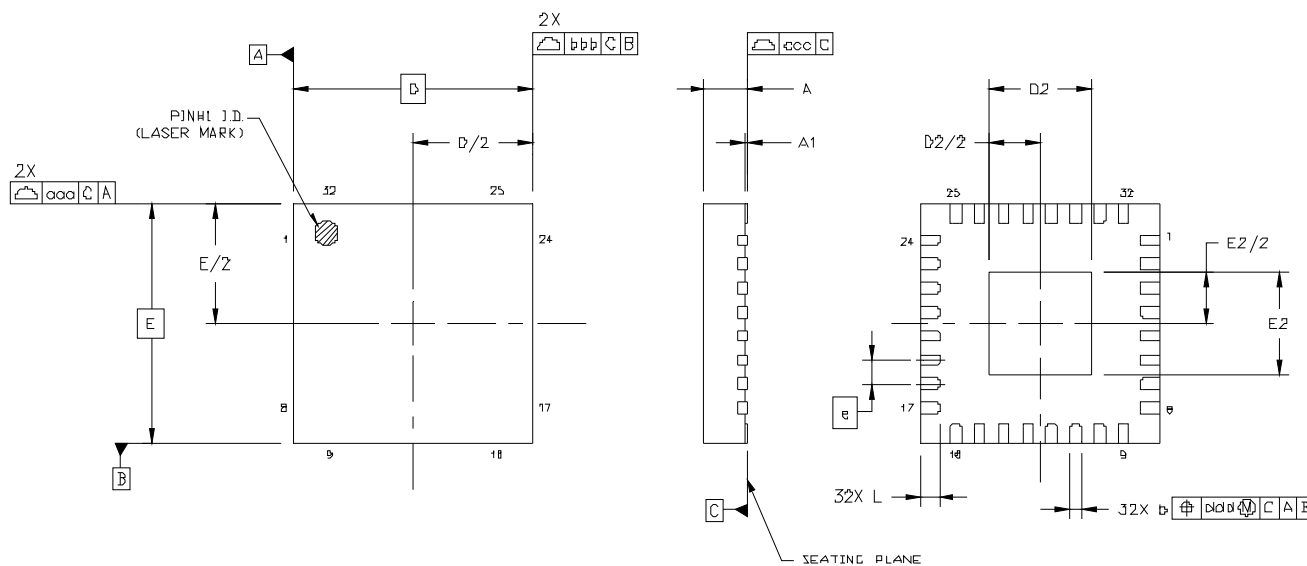

Figure 12. Si53314 5x5 mm Package Diagram

Table 19. Package Dimensions

Dimension	Min	Nom	Max
A	0.80	0.85	1.00
A1	0.00	0.02	0.05
b	0.18	0.25	0.30
c	0.20	0.25	0.30
D	5.00 BSC		
D2	2.00	2.15	2.30
e	0.50 BSC		
E	5.00 BSC		
E2	2.00	2.15	2.30
L	0.30	0.40	0.50
aaa	0.10		
bbb	0.10		
ccc	0.08		
ddd	0.10		
Notes:			
1. All dimensions shown are in millimeters (mm) unless otherwise noted.			
2. Dimensioning and Tolerancing per ANSI Y14.5M-1994.			
3. This drawing conforms to the JEDEC Solid State Outline MO-220.			

6. PCB Land Pattern

6.1. 5x5 mm 32-QFN Package Land Pattern

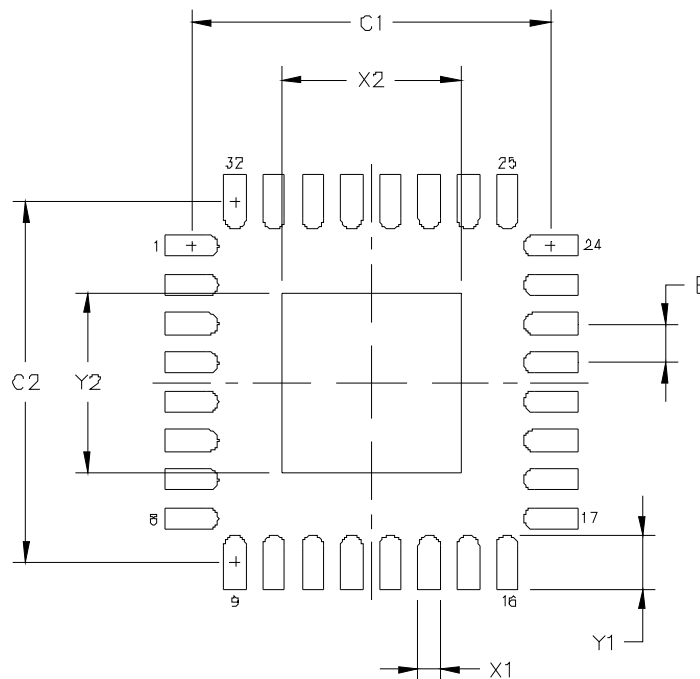

Figure 13. Si53314 5x5 mm Package Land Pattern

Table 20. PCB Land Pattern

Dimension	Min	Max	Dimension	Min	Max
C1	4.52	4.62	X2	2.20	2.30
C2	4.52	4.62	Y1	0.59	0.69
E	0.50 BSC		Y2	2.20	2.30
X1	0.20	0.30			

Notes:

General

1. All dimensions shown are in millimeters (mm) unless otherwise noted.
2. This Land Pattern Design is based on the IPC-7351 guidelines.

Solder Mask Design

1. All metal pads are to be non-solder mask defined (NSMD). Clearance between the solder mask and the metal pad is to be 60 μm minimum, all the way around the pad.

Stencil Design

1. A stainless steel, laser-cut and electro-polished stencil with trapezoidal walls should be used to assure good solder paste release.
2. The stencil thickness should be 0.125 mm (5 mils).
3. The ratio of stencil aperture to land pad size should be 1:1 for all perimeter pads.
4. A 2x2 array of 0.75 mm square openings on 1.15 mm pitch should be used for the center ground pad.

Card Assembly

1. A No-Clean, Type-3 solder paste is recommended.
2. The recommended card reflow profile is per the JEDEC/IPC J-STD-020 specification for Small Body Components.

7. Top Marking

7.1. Si53314 Top Marking

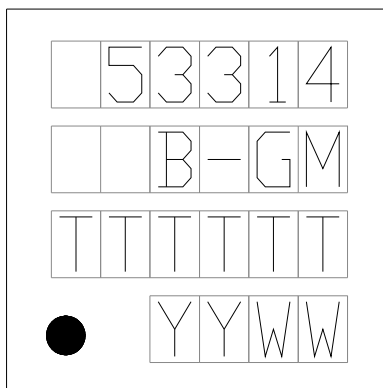

7.2. Top Marking Explanation

Mark Method:	Laser	
Font Size:	2.0 Point (28 mils) Center-Justified	
Line 1 Marking:	Device Part Number	53314
Line 2 Marking:	Device Revision/Type	B-GM
Line 3 Marking:	YY = Year WW = Work Week	Assigned by the Assembly House. Corresponds to the year and work week of the mold date.
	R = Die Rev F = Wafer Fab	First two characters of the Manufacturing Code from the Assembly Purchase Order form.
Line 4 Marking	Circle = 0.5 mm Diameter Lower-Left Justified	Pin 1 Identifier
	A = Assembly Site I = Internal Code XX = Serial Lot Number	Last four characters of the Manufacturing Code from the Assembly Purchase Order form.

CONTACT INFORMATION

Silicon Laboratories Inc.

400 West Cesar Chavez
Austin, TX 78701
Tel: 1+(512) 416-8500
Fax: 1+(512) 416-9669
Toll Free: 1+(877) 444-3032

Please visit the Silicon Labs Technical Support web page:
<https://www.silabs.com/support/pages/contacttechnicalsupport.aspx>
and register to submit a technical support request.

Patent Notice

Silicon Labs invests in research and development to help our customers differentiate in the market with innovative low-power, small size, analog-intensive mixed-signal solutions. Silicon Labs' extensive patent portfolio is a testament to our unique approach and world-class engineering team.

The information in this document is believed to be accurate in all respects at the time of publication but is subject to change without notice. Silicon Laboratories assumes no responsibility for errors and omissions, and disclaims responsibility for any consequences resulting from the use of information included herein. Additionally, Silicon Laboratories assumes no responsibility for the functioning of undescribed features or parameters. Silicon Laboratories reserves the right to make changes without further notice. Silicon Laboratories makes no warranty, representation or guarantee regarding the suitability of its products for any particular purpose, nor does Silicon Laboratories assume any liability arising out of the application or use of any product or circuit, and specifically disclaims any and all liability, including without limitation consequential or incidental damages. Silicon Laboratories products are not designed, intended, or authorized for use in applications intended to support or sustain life, or for any other application in which the failure of the Silicon Laboratories product could create a situation where personal injury or death may occur. Should Buyer purchase or use Silicon Laboratories products for any such unintended or unauthorized application, Buyer shall indemnify and hold Silicon Laboratories harmless against all claims and damages.

Silicon Laboratories and Silicon Labs are trademarks of Silicon Laboratories Inc.
Other products or brandnames mentioned herein are trademarks or registered trademarks of their respective holders.

Mouser Electronics

Authorized Distributor

Click to View Pricing, Inventory, Delivery & Lifecycle Information:

[Silicon Laboratories:](#)

[Si53314-B-GM](#)