

### FEATURES

**Latch-up proof**  
**3 pF off source capacitance**  
**5 pF off drain capacitance**  
**0.07 pC charge injection**  
**Low leakage: 0.2 nA maximum at 85°C**  
**±9 V to ±22 V dual-supply operation**  
**9 V to 40 V single-supply operation**  
**48 V supply maximum ratings**  
**Fully specified at ±15 V, ±20 V, +12 V, and +36 V**  
 **$V_{SS}$  to  $V_{DD}$  analog signal range**

### APPLICATIONS

**Automatic test equipment**  
**Data acquisition**  
**Instrumentation**  
**Avionics**  
**Audio and video switching**  
**Communication systems**

### GENERAL DESCRIPTION

The ADG5212/ADG5213 contain four independent single-pole/single-throw (SPST) switches. The ADG5212 switches turn on with Logic 1. The ADG5213 has two switches with digital control logic similar to that of the ADG5212; however, the logic is inverted on the other two switches. Each switch conducts equally well in both directions when on, and each switch has an input signal range that extends to the supplies. In the off condition, signal levels up to the supplies are blocked.

The ADG5212 and ADG5213 do not have a  $V_L$  pin. The digital inputs are compatible with 3 V logic inputs over the full operating supply range.

The ultralow capacitance and charge injection of these switches make them ideal solutions for data acquisition and sample-and-hold applications, where low glitch and fast settling are required. Fast switching speed together with high signal bandwidth make the parts suitable for video signal switching.

### FUNCTIONAL BLOCK DIAGRAMS

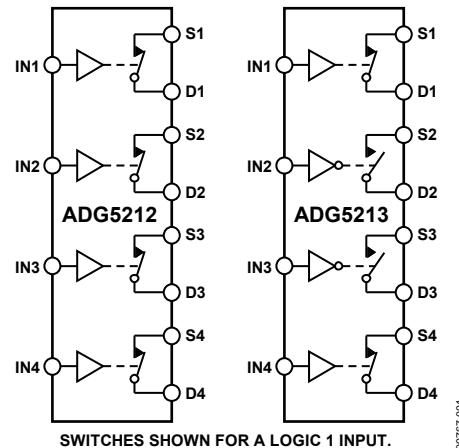

Figure 1.

### PRODUCT HIGHLIGHTS

1. Trench Isolation Guards Against Latch-Up.  
A dielectric trench separates the P and N channel transistors, thereby preventing latch-up even under severe overvoltage conditions.
2. Ultralow Capacitance and <1 pC Charge Injection.
3. Dual-Supply Operation.  
For applications where the analog signal is bipolar, the ADG5212/ADG5213 can be operated from dual supplies of up to ±22 V.
4. Single-Supply Operation.  
For applications where the analog signal is unipolar, the ADG5212/ADG5213 can be operated from a single rail power supply of up to 40 V.
5. 3 V Logic-Compatible Digital Inputs.  
 $V_{INH} = 2.0$  V,  $V_{INL} = 0.8$  V.
6. No  $V_L$  Logic Power Supply Required.

#### Rev. 0

Information furnished by Analog Devices is believed to be accurate and reliable. However, no responsibility is assumed by Analog Devices for its use, nor for any infringements of patents or other rights of third parties that may result from its use. Specifications subject to change without notice. No license is granted by implication or otherwise under any patent or patent rights of Analog Devices. Trademarks and registered trademarks are the property of their respective owners.

## TABLE OF CONTENTS

Features .....	1	Continuous Current per Channel, Sx or Dx.....	7
Applications.....	1	Absolute Maximum Ratings .....	8
Functional Block Diagrams.....	1	ESD Caution.....	8
General Description .....	1	Pin Configurations and Function Descriptions .....	9
Product Highlights .....	1	Typical Performance Characteristics .....	10
Revision History .....	2	Test Circuits.....	14
Specifications.....	3	Terminology .....	16
±15 V Dual Supply .....	3	Trench Isolation .....	17
±20 V Dual Supply .....	4	Applications Information .....	18
12 V Single Supply.....	5	Outline Dimensions .....	19
36 V Single Supply.....	6	Ordering Guide .....	19

## REVISION HISTORY

4/11—Revision 0: Initial Version

# SPECIFICATIONS

## ±15 V DUAL SUPPLY

$V_{DD} = +15\text{ V} \pm 10\%$ ,  $V_{SS} = -15\text{ V} \pm 10\%$ ,  $GND = 0\text{ V}$ , unless otherwise noted.

**Table 1.**

Parameter	25°C	-40°C to +85°C	-40°C to +125°C	Unit	Test Conditions/Comments
<b>ANALOG SWITCH</b>					
Analog Signal Range			$V_{DD}$ to $V_{SS}$	V max	
On Resistance, $R_{ON}$	160			$\Omega$ typ	$V_S = \pm 10\text{ V}$ , $I_S = -1\text{ mA}$ , see Figure 24
On-Resistance Match Between Channels, $\Delta R_{ON}$	200	250	280	$\Omega$ max	$V_{DD} = +13.5\text{ V}$ , $V_{SS} = -13.5\text{ V}$
	2			$\Omega$ typ	$V_S = \pm 10\text{ V}$ , $I_S = -1\text{ mA}$
On-Resistance Flatness, $R_{FLAT(ON)}$	8	9	10	$\Omega$ max	
	38			$\Omega$ typ	$V_S = \pm 10\text{ V}$ , $I_S = -1\text{ mA}$
	50	65	70	$\Omega$ max	
<b>LEAKAGE CURRENTS</b>					
Source Off Leakage, $I_S$ (Off)	0.01			nA typ	$V_{DD} = +16.5\text{ V}$ , $V_{SS} = -16.5\text{ V}$ $V_S = \pm 10\text{ V}$ , $V_D = \mp 10\text{ V}$ , see Figure 23
Drain Off Leakage, $I_D$ (Off)	0.1	0.2	0.4	nA max	
	0.01			nA typ	$V_S = \pm 10\text{ V}$ , $V_D = \mp 10\text{ V}$ , see Figure 23
Channel On Leakage, $I_D$ (On), $I_S$ (On)	0.1	0.2	0.4	nA max	
	0.02			nA typ	$V_S = V_D = \pm 10\text{ V}$ , see Figure 26
	0.2	0.25	0.9	nA max	
<b>DIGITAL INPUTS</b>					
Input High Voltage, $V_{INH}$			2.0	V min	
Input Low Voltage, $V_{INL}$			0.8	V max	
Input Current, $I_{INL}$ or $I_{INH}$	0.002			$\mu\text{A}$ typ	$V_{IN} = V_{GND}$ or $V_{DD}$
			$\pm 0.1$	$\mu\text{A}$ max	
Digital Input Capacitance, $C_{IN}$	3			pF typ	
<b>DYNAMIC CHARACTERISTICS<sup>1</sup></b>					
$t_{ON}$	175			ns typ	$R_L = 300\ \Omega$ , $C_L = 35\text{ pF}$
	210	255	280	ns max	$V_S = 10\text{ V}$ , see Figure 30
$t_{OFF}$	140			ns typ	$R_L = 300\ \Omega$ , $C_L = 35\text{ pF}$
	170	195	215	ns max	$V_S = 10\text{ V}$ , see Figure 30
Break-Before-Make Time Delay, $t_D$ (ADG5213 Only)	40			ns typ	$R_L = 300\ \Omega$ , $C_L = 35\text{ pF}$
Charge Injection, $Q_{INJ}$			20	ns min	$V_{S1} = V_{S2} = 10\text{ V}$ , see Figure 29
	0.07			pC typ	$V_S = 0\text{ V}$ , $R_S = 0\ \Omega$ , $C_L = 1\text{ nF}$ , see Figure 31
Off Isolation	-105			dB typ	$R_L = 50\ \Omega$ , $C_L = 5\text{ pF}$ , $f = 1\text{ MHz}$ , see Figure 25
Channel-to-Channel Crosstalk	-105			dB typ	$R_L = 50\ \Omega$ , $C_L = 5\text{ pF}$ , $f = 1\text{ MHz}$ , see Figure 27
-3 dB Bandwidth	435			MHz typ	$R_L = 50\ \Omega$ , $C_L = 5\text{ pF}$ , see Figure 28
Insertion Loss	-6.8			dB typ	$R_L = 50\ \Omega$ , $C_L = 5\text{ pF}$ , $f = 1\text{ MHz}$ , see Figure 28
$C_S$ (Off)	3			pF typ	$V_S = 0\text{ V}$ , $f = 1\text{ MHz}$
$C_D$ (Off)	5			pF typ	$V_S = 0\text{ V}$ , $f = 1\text{ MHz}$
$C_D$ (On), $C_S$ (On)	8			pF typ	$V_S = 0\text{ V}$ , $f = 1\text{ MHz}$
<b>POWER REQUIREMENTS</b>					
$I_{DD}$	45			$\mu\text{A}$ typ	$V_{DD} = +16.5\text{ V}$ , $V_{SS} = -16.5\text{ V}$ Digital inputs = 0 V or $V_{DD}$
	55		70	$\mu\text{A}$ max	
$I_{SS}$	0.001			$\mu\text{A}$ typ	Digital inputs = 0 V or $V_{DD}$
			1	$\mu\text{A}$ max	
$V_{DD}/V_{SS}$			$\pm 9/\pm 22$	V min/V max	$GND = 0\text{ V}$

<sup>1</sup> Guaranteed by design; not subject to production test.

# ADG5212/ADG5213

## ±20 V DUAL SUPPLY

$V_{DD} = +20\text{ V} \pm 10\%$ ,  $V_{SS} = -20\text{ V} \pm 10\%$ , GND = 0 V, unless otherwise noted.

Table 2.

Parameter	25°C	-40°C to +85°C	-40°C to +125°C	Unit	Test Conditions/Comments
<b>ANALOG SWITCH</b>					
Analogue Signal Range			$V_{DD}$ to $V_{SS}$	V max	
On Resistance, $R_{ON}$	140			$\Omega$ typ	$V_S = \pm 15\text{ V}$ , $I_S = -1\text{ mA}$ , see Figure 24
On-Resistance Match Between Channels, $\Delta R_{ON}$	160 1.5	200	230	$\Omega$ max $\Omega$ typ	$V_{DD} = +18\text{ V}$ , $V_{SS} = -18\text{ V}$ $V_S = \pm 15\text{ V}$ , $I_S = -1\text{ mA}$
On-Resistance Flatness, $R_{FLAT(ON)}$	8 33 45	9	10 60	$\Omega$ max $\Omega$ typ $\Omega$ max	$V_S = \pm 15\text{ V}$ , $I_S = -1\text{ mA}$
<b>LEAKAGE CURRENTS</b>					
Source Off Leakage, $I_S$ (Off)	0.01			nA typ	$V_{DD} = +22\text{ V}$ , $V_{SS} = -22\text{ V}$ $V_S = \pm 15\text{ V}$ , $V_D = \mp 15\text{ V}$ , see Figure 23
Drain Off Leakage, $I_D$ (Off)	0.1 0.01	0.2	0.4	nA max nA typ	$V_S = \pm 15\text{ V}$ , $V_D = \mp 15\text{ V}$ , see Figure 23
Channel On Leakage, $I_D$ (On), $I_S$ (On)	0.1 0.02 0.2	0.2	0.4 0.9	nA max nA typ nA max	$V_S = V_D = \pm 15\text{ V}$ , see Figure 26
<b>DIGITAL INPUTS</b>					
Input High Voltage, $V_{INH}$			2.0	V min	
Input Low Voltage, $V_{INL}$			0.8	V max	
Input Current, $I_{INL}$ or $I_{INH}$	0.002		$\pm 0.1$	$\mu\text{A}$ typ $\mu\text{A}$ max	$V_{IN} = V_{GND}$ or $V_{DD}$
Digital Input Capacitance, $C_{IN}$	3			pF typ	
<b>DYNAMIC CHARACTERISTICS<sup>1</sup></b>					
$t_{ON}$	155 195	235	255	ns typ ns max	$R_L = 300\ \Omega$ , $C_L = 35\text{ pF}$ $V_S = 10\text{ V}$ , see Figure 30
$t_{OFF}$	145 165	185	210	ns typ ns max	$R_L = 300\ \Omega$ , $C_L = 35\text{ pF}$ $V_S = 10\text{ V}$ , see Figure 30
Break-Before-Make Time Delay, $t_D$ (ADG5213 Only)	35		20	ns typ	$R_L = 300\ \Omega$ , $C_L = 35\text{ pF}$
Charge Injection, $Q_{INJ}$	-0.5			ns min pC typ	$V_{S1} = V_{S2} = 10\text{ V}$ , see Figure 29 $V_S = 0\text{ V}$ , $R_S = 0\ \Omega$ , $C_L = 1\text{ nF}$ , see Figure 31
Off Isolation	-105			dB typ	$R_L = 50\ \Omega$ , $C_L = 5\text{ pF}$ , $f = 1\text{ MHz}$ , see Figure 25
Channel-to-Channel Crosstalk	-105			dB typ	$R_L = 50\ \Omega$ , $C_L = 5\text{ pF}$ , $f = 1\text{ MHz}$ , see Figure 27
-3 dB Bandwidth	460			MHz typ	$R_L = 50\ \Omega$ , $C_L = 5\text{ pF}$ , see Figure 28
Insertion Loss	-6			dB typ	$R_L = 50\ \Omega$ , $C_L = 5\text{ pF}$ , $f = 1\text{ MHz}$ , see Figure 28
$C_S$ (Off)	2.8			pF typ	$V_S = 0\text{ V}$ , $f = 1\text{ MHz}$
$C_D$ (Off)	4.8			pF typ	$V_S = 0\text{ V}$ , $f = 1\text{ MHz}$
$C_D$ (On), $C_S$ (On)	8			pF typ	$V_S = 0\text{ V}$ , $f = 1\text{ MHz}$

Parameter	25°C	-40°C to +85°C	-40°C to +125°C	Unit	Test Conditions/Comments
<b>POWER REQUIREMENTS</b>					
$I_{DD}$	50			$\mu\text{A typ}$	$V_{DD} = +22\text{ V}$ , $V_{SS} = -22\text{ V}$ Digital inputs = 0 V or $V_{DD}$
$I_{SS}$	70		110	$\mu\text{A max}$	
	0.001			$\mu\text{A typ}$	Digital inputs = 0 V or $V_{DD}$
$V_{DD}/V_{SS}$			1	$\mu\text{A max}$	
			$\pm 9/\pm 22$	V min/V max	GND = 0 V

<sup>1</sup> Guaranteed by design; not subject to production test.

## 12 V SINGLE SUPPLY

$V_{DD} = 12\text{ V} \pm 10\%$ ,  $V_{SS} = 0\text{ V}$ , GND = 0 V, unless otherwise noted.

**Table 3.**

Parameter	25°C	-40°C to +85°C	-40°C to +125°C	Unit	Test Conditions/Comments
<b>ANALOG SWITCH</b>					
Analog Signal Range			0 V to $V_{DD}$	V max	
On Resistance, $R_{ON}$	350			$\Omega\text{ typ}$	$V_S = 0\text{ V to }10\text{ V}$ , $I_S = -1\text{ mA}$ , see Figure 24
On-Resistance Match Between Channels, $\Delta R_{ON}$	500	610	700	$\Omega\text{ max}$	$V_{DD} = 10.8\text{ V}$ , $V_{SS} = 0\text{ V}$
	4			$\Omega\text{ typ}$	$V_S = 0\text{ V to }10\text{ V}$ , $I_S = -1\text{ mA}$
On-Resistance Flatness, $R_{FLAT(ON)}$	20	21	22	$\Omega\text{ max}$	
	160			$\Omega\text{ typ}$	$V_S = 0\text{ V to }10\text{ V}$ , $I_S = -1\text{ mA}$
	280	335	370	$\Omega\text{ max}$	
<b>LEAKAGE CURRENTS</b>					
Source Off Leakage, $I_S$ (Off)	0.01			nA typ	$V_{DD} = 13.2\text{ V}$ , $V_{SS} = 0\text{ V}$ $V_S = 1\text{ V}/10\text{ V}$ , $V_D = 10\text{ V}/1\text{ V}$ , see Figure 23
Drain Off Leakage, $I_D$ (Off)	0.1	0.2	0.4	nA max	
	0.01			nA typ	$V_S = 1\text{ V}/10\text{ V}$ , $V_D = 10\text{ V}/1\text{ V}$ , see Figure 23
Channel On Leakage, $I_D$ (On), $I_S$ (On)	0.1	0.2	0.4	nA max	
	0.02			nA typ	$V_S = V_D = 1\text{ V}/10\text{ V}$ , see Figure 26
	0.2	0.25	0.9	nA max	
<b>DIGITAL INPUTS</b>					
Input High Voltage, $V_{INH}$			2.0	V min	
Input Low Voltage, $V_{INL}$			0.8	V max	
Input Current, $I_{INL}$ or $I_{INH}$	0.002			$\mu\text{A typ}$	$V_{IN} = V_{GND}$ or $V_{DD}$
			$\pm 0.1$	$\mu\text{A max}$	
Digital Input Capacitance, $C_{IN}$	3			pF typ	
<b>DYNAMIC CHARACTERISTICS<sup>1</sup></b>					
$t_{ON}$	235			ns typ	$R_L = 300\ \Omega$ , $C_L = 35\text{ pF}$
	290	360	410	ns max	$V_S = 8\text{ V}$ , see Figure 30
$t_{OFF}$	165			ns typ	$R_L = 300\ \Omega$ , $C_L = 35\text{ pF}$
	205	235	260	ns max	$V_S = 8\text{ V}$ , see Figure 30
Break-Before-Make Time Delay, $t_D$ (ADG5213 Only)	85			ns typ	$R_L = 300\ \Omega$ , $C_L = 35\text{ pF}$
			50	ns min	$V_{S1} = V_{S2} = 8\text{ V}$ , see Figure 29
Charge Injection, $Q_{INU}$	-0.5			pC typ	$V_S = 6\text{ V}$ , $R_S = 0\ \Omega$ , $C_L = 1\text{ nF}$ , see Figure 31
Off Isolation	-105			dB typ	$R_L = 50\ \Omega$ , $C_L = 5\text{ pF}$ , $f = 1\text{ MHz}$ , see Figure 25
Channel-to-Channel Crosstalk	-105			dB typ	$R_L = 50\ \Omega$ , $C_L = 5\text{ pF}$ , $f = 1\text{ MHz}$ , see Figure 27
-3 dB Bandwidth	340			MHz typ	$R_L = 50\ \Omega$ , $C_L = 5\text{ pF}$ , see Figure 28

# ADG5212/ADG5213

Parameter	25°C	-40°C to +85°C	-40°C to +125°C	Unit	Test Conditions/Comments
Insertion Loss	-11			dB typ	$R_L = 50 \Omega$ , $C_L = 5 \text{ pF}$ , $f = 1 \text{ MHz}$ , see Figure 28
$C_S$ (Off)	3.5			pF typ	$V_S = 6 \text{ V}$ , $f = 1 \text{ MHz}$
$C_D$ (Off)	5.5			pF typ	$V_S = 6 \text{ V}$ , $f = 1 \text{ MHz}$
$C_D$ (On), $C_S$ (On)	9			pF typ	$V_S = 6 \text{ V}$ , $f = 1 \text{ MHz}$
<b>POWER REQUIREMENTS</b>					
$I_{DD}$	40		65	$\mu\text{A}$ typ $\mu\text{A}$ max	$V_{DD} = 13.2 \text{ V}$ Digital inputs = 0 V or $V_{DD}$
$V_{DD}$			9/40	V min/V max	GND = 0 V, $V_{SS} = 0 \text{ V}$

<sup>1</sup> Guaranteed by design; not subject to production test.

## 36 V SINGLE SUPPLY

$V_{DD} = 36 \text{ V} \pm 10\%$ ,  $V_{SS} = 0 \text{ V}$ , GND = 0 V, unless otherwise noted.

**Table 4.**

Parameter	25°C	-40°C to +85°C	-40°C to +125°C	Unit	Test Conditions/Comments
<b>ANALOG SWITCH</b>					
Analog Signal Range			0 V to $V_{DD}$	V max	
On Resistance, $R_{ON}$	150			$\Omega$ typ	$V_S = 0 \text{ V}$ to 30 V, $I_S = -1 \text{ mA}$ , see Figure 24
	170	215	245	$\Omega$ max	$V_{DD} = 32.4 \text{ V}$ , $V_{SS} = 0 \text{ V}$
On-Resistance Match Between Channels, $\Delta R_{ON}$	1.6			$\Omega$ typ	$V_S = 0 \text{ V}$ to 30 V, $I_S = -1 \text{ mA}$
	8	9	10	$\Omega$ max	
On-Resistance Flatness, $R_{FLAT(ON)}$	35			$\Omega$ typ	$V_S = 0 \text{ V}$ to 30 V, $I_S = -1 \text{ mA}$
	50	60	65	$\Omega$ max	
<b>LEAKAGE CURRENTS</b>					
Source Off Leakage, $I_S$ (Off)	0.01			nA typ	$V_{DD} = 39.6 \text{ V}$ , $V_{SS} = 0 \text{ V}$ $V_S = 1 \text{ V}/30 \text{ V}$ , $V_D = 30 \text{ V}/1 \text{ V}$ , see Figure 23
	0.1	0.2	0.4	nA max	
Drain Off Leakage, $I_D$ (Off)	0.01			nA typ	$V_S = 1 \text{ V}/30 \text{ V}$ , $V_D = 30 \text{ V}/1 \text{ V}$ , see Figure 23
	0.1	0.2	0.4	nA max	
Channel On Leakage, $I_D$ (On), $I_S$ (On)	0.02			nA typ	$V_S = V_D = 1 \text{ V}/30 \text{ V}$ , see Figure 26
	0.2	0.25	0.9	nA max	
<b>DIGITAL INPUTS</b>					
Input High Voltage, $V_{INH}$			2.0	V min	
Input Low Voltage, $V_{INL}$			0.8	V max	
Input Current, $I_{INL}$ or $I_{INH}$	0.002			$\mu\text{A}$ typ	$V_{IN} = V_{GND}$ or $V_{DD}$
			$\pm 0.1$	$\mu\text{A}$ max	
Digital Input Capacitance, $C_{IN}$	3			pF typ	
<b>DYNAMIC CHARACTERISTICS<sup>1</sup></b>					
$t_{ON}$	190			ns typ	$R_L = 300 \Omega$ , $C_L = 35 \text{ pF}$
	230	255	265	ns max	$V_S = 18 \text{ V}$ , see Figure 30
$t_{OFF}$	175			ns typ	$R_L = 300 \Omega$ , $C_L = 35 \text{ pF}$
	215	230	245	ns max	$V_S = 18 \text{ V}$ , see Figure 30
Break-Before-Make Time Delay, $t_D$ (ADG5213 Only)	45			ns typ	$R_L = 300 \Omega$ , $C_L = 35 \text{ pF}$
			25	ns min	$V_{S1} = V_{S2} = 18 \text{ V}$ , see Figure 29
Charge Injection, $Q_{INJ}$	-0.5			pC typ	$V_S = 18 \text{ V}$ , $R_S = 0 \Omega$ , $C_L = 1 \text{ nF}$ , see Figure 31
Off Isolation	-105			dB typ	$R_L = 50 \Omega$ , $C_L = 5 \text{ pF}$ , $f = 1 \text{ MHz}$ , see Figure 25
Channel-to-Channel Crosstalk	-105			dB typ	$R_L = 50 \Omega$ , $C_L = 5 \text{ pF}$ , $f = 1 \text{ MHz}$ , Figure 27

Parameter	25°C	-40°C to +85°C	-40°C to +125°C	Unit	Test Conditions/Comments
-3 dB Bandwidth	410			MHz typ	$R_L = 50 \Omega$ , $C_L = 5 \text{ pF}$ , see Figure 28
Insertion Loss	-6.8			dB typ	$R_L = 50 \Omega$ , $C_L = 5 \text{ pF}$ , $f = 1 \text{ MHz}$ , see Figure 28
$C_S$ (Off)	3			pF typ	$V_S = 18 \text{ V}$ , $f = 1 \text{ MHz}$
$C_D$ (Off)	5			pF typ	$V_S = 18 \text{ V}$ , $f = 1 \text{ MHz}$
$C_D$ (On), $C_S$ (On)	8			pF typ	$V_S = 18 \text{ V}$ , $f = 1 \text{ MHz}$
<b>POWER REQUIREMENTS</b>					$V_{DD} = 39.6 \text{ V}$
$I_{DD}$	80		130	$\mu\text{A}$ typ	Digital inputs = 0 V or $V_{DD}$
	100		9/40	$\mu\text{A}$ max	
$V_{DD}$				V min/V max	GND = 0 V, $V_{SS} = 0 \text{ V}$

<sup>1</sup> Guaranteed by design; not subject to production test.

## CONTINUOUS CURRENT PER CHANNEL, Sx OR Dx

Table 5.

Parameter	25°C	85°C	125°C	Unit
<b>CONTINUOUS CURRENT, Sx or Dx</b>				
$V_{DD} = +15 \text{ V}$ , $V_{SS} = -15 \text{ V}$				
TSSOP ( $\theta_{JA} = 112.6^\circ\text{C/W}$ )	18	10	5	mA maximum
LFCSP ( $\theta_{JA} = 30.4^\circ\text{C/W}$ )	32	15	6	mA maximum
$V_{DD} = +20 \text{ V}$ , $V_{SS} = -20 \text{ V}$				
TSSOP ( $\theta_{JA} = 112.6^\circ\text{C/W}$ )	29	16	8	mA maximum
LFCSP ( $\theta_{JA} = 30.4^\circ\text{C/W}$ )	50	22	9	mA maximum
$V_{DD} = 12 \text{ V}$ , $V_{SS} = 0 \text{ V}$				
TSSOP ( $\theta_{JA} = 112.6^\circ\text{C/W}$ )	18	12	7	mA maximum
LFCSP ( $\theta_{JA} = 30.4^\circ\text{C/W}$ )	32	17	8	mA maximum
$V_{DD} = 36 \text{ V}$ , $V_{SS} = 0 \text{ V}$				
TSSOP ( $\theta_{JA} = 112.6^\circ\text{C/W}$ )	34	18	8	mA maximum
LFCSP ( $\theta_{JA} = 30.4^\circ\text{C/W}$ )	59	24	9	mA maximum

## ABSOLUTE MAXIMUM RATINGS

T<sub>A</sub> = 25°C, unless otherwise noted.

Table 6.

Parameter	Rating
V <sub>DD</sub> to V <sub>SS</sub>	48 V
V <sub>DD</sub> to GND	−0.3 V to +48 V
V <sub>SS</sub> to GND	+0.3 V to −48 V
Analog Inputs <sup>1</sup>	V <sub>SS</sub> − 0.3 V to V <sub>DD</sub> + 0.3 V or 30 mA, whichever occurs first
Digital Inputs <sup>1</sup>	V <sub>SS</sub> − 0.3 V to V <sub>DD</sub> + 0.3 V or 30 mA, whichever occurs first
Peak Current, Sx or Dx Pin	60 mA (pulsed at 1 ms, 10% duty cycle maximum)
Continuous Current, Sx or Dx <sup>2</sup>	Data + 15%
Temperature	
Operating Range	−40°C to +125°C
Storage Range	−65°C to +150°C
Junction	150°C
Thermal Impedance, θ <sub>JA</sub>	
16-Lead TSSOP (4-Layer Board)	112.6°C/W
16-Lead LFCSOP (4-Layer Board)	30.4°C/W
Reflow Soldering Peak Temperature, Pb Free	260(+0/−5)°C

<sup>1</sup> Overvoltages at the INx, Sx, and Dx pins are clamped by internal diodes.  
Limit current to the maximum ratings given.

<sup>2</sup> See Table 5.

Stresses above those listed under Absolute Maximum Ratings may cause permanent damage to the device. This is a stress rating only; functional operation of the device at these or any other conditions above those indicated in the operational section of this specification is not implied. Exposure to absolute maximum rating conditions for extended periods may affect device reliability.

Only one absolute maximum rating can be applied at any one time.

### ESD CAUTION



**ESD (electrostatic discharge) sensitive device.** Charged devices and circuit boards can discharge without detection. Although this product features patented or proprietary protection circuitry, damage may occur on devices subjected to high energy ESD. Therefore, proper ESD precautions should be taken to avoid performance degradation or loss of functionality.

## PIN CONFIGURATIONS AND FUNCTION DESCRIPTIONS

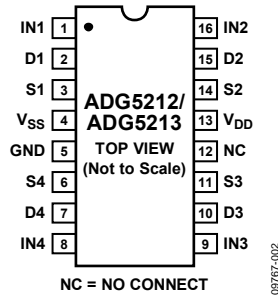
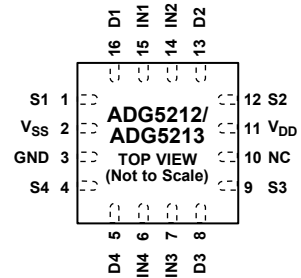

Figure 2. TSSOP Pin Configuration



NOTES  
 1. EXPOSED PAD TIED TO SUBSTRATE,  $V_{SS}$ .  
 2. NC = NO CONNECT.

Figure 3. LFCSP Pin Configuration

Table 7. Pin Function Descriptions

Pin No.		Mnemonic	Description
TSSOP	LFCSP		
1	15	IN1	Logic Control Input.
2	16	D1	Drain Terminal. This pin can be an input or an output.
3	1	S1	Source Terminal. This pin can be an input or an output.
4	2	$V_{SS}$	Most Negative Power Supply Potential.
5	3	GND	Ground (0 V) Reference.
6	4	S4	Source Terminal. This pin can be an input or an output.
7	5	D4	Drain Terminal. This pin can be an input or an output.
8	6	IN4	Logic Control Input.
9	7	IN3	Logic Control Input.
10	8	D3	Drain Terminal. This pin can be an input or an output.
11	9	S3	Source Terminal. This pin can be an input or an output.
12	10	NC	No Connect. These pins are open.
13	11	$V_{DD}$	Most Positive Power Supply Potential.
14	12	S2	Source Terminal. This pin can be an input or an output.
15	13	D2	Drain Terminal. This pin can be an input or an output.
16	14	IN2	Logic Control Input.
N/A <sup>1</sup>	EP	Exposed pad	Exposed Pad. The exposed pad is connected internally. For increased reliability of the solder joints and maximum thermal capability, it is recommended that the pad be soldered to the substrate, $V_{SS}$ .

<sup>1</sup> N/A means not applicable.

Table 8. ADG5212 Truth Table

ADG5212 INx	Switch Condition
1	On
0	Off

Table 9. ADG5213 Truth Table

ADG5213 INx	S1, S4	S2, S3
0	Off	On
1	On	Off

## TYPICAL PERFORMANCE CHARACTERISTICS

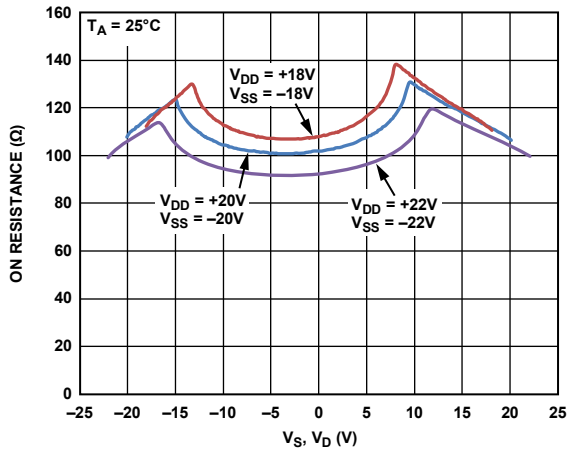

Figure 4.  $R_{ON}$  as a Function of  $V_S, V_D$  (Dual Supply)

09767-104

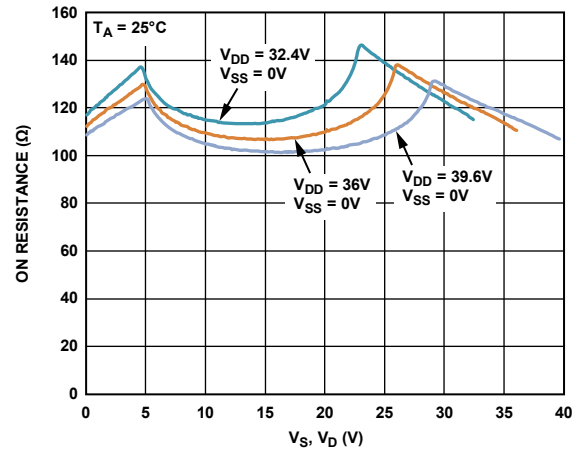

Figure 7.  $R_{ON}$  as a Function of  $V_S, V_D$  (Single Supply)

09767-107

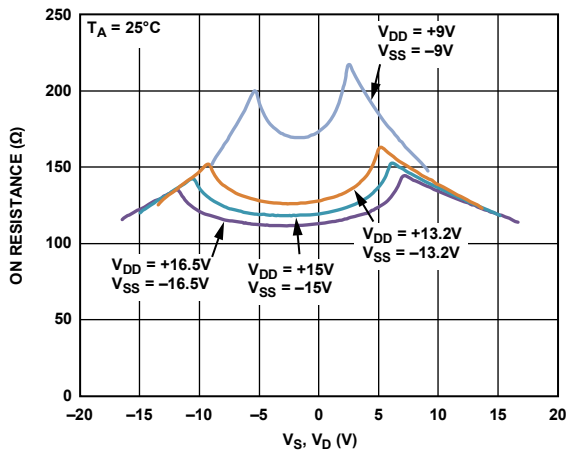

Figure 5.  $R_{ON}$  as a Function of  $V_S, V_D$  (Dual Supply)

09767-105

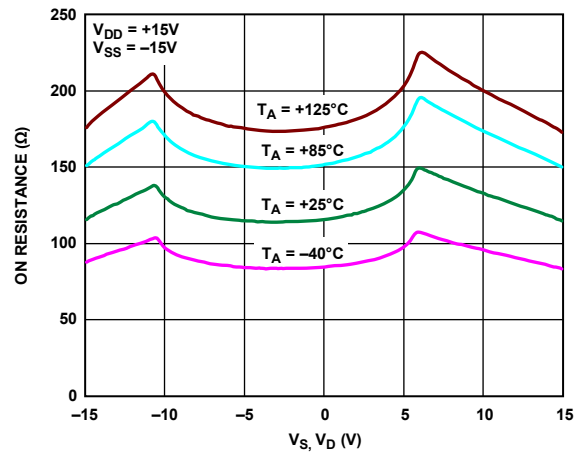

Figure 8.  $R_{ON}$  as a Function of  $V_S, V_D$  for Different Temperatures,  $\pm 15$  V Dual Supply

09767-108

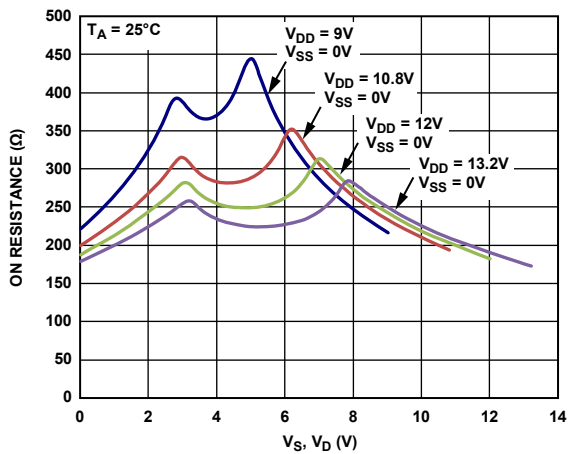

Figure 6.  $R_{ON}$  as a Function of  $V_S, V_D$  (Single Supply)

09767-106

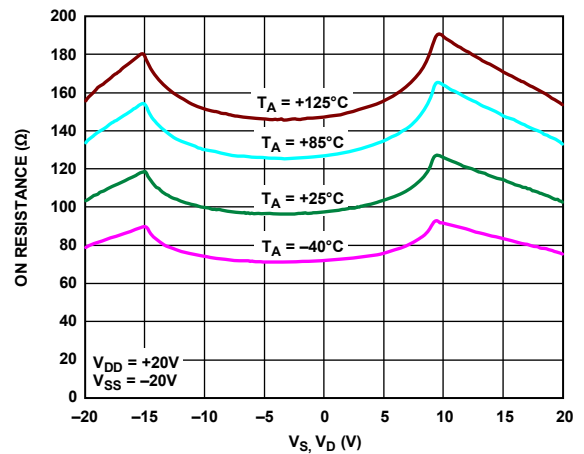

Figure 9.  $R_{ON}$  as a Function of  $V_S, V_D$  for Different Temperatures,  $\pm 20$  V Dual Supply

09767-109

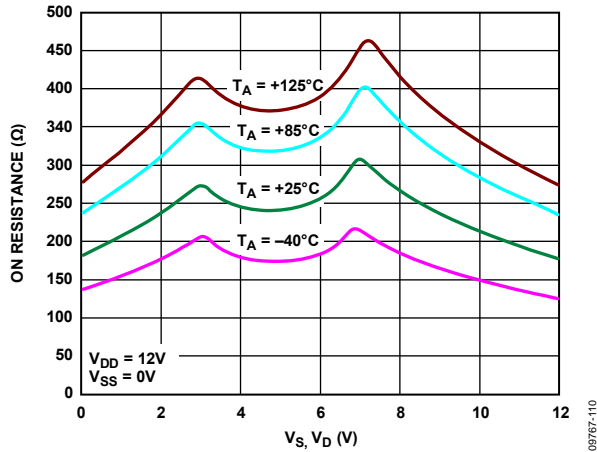

Figure 10.  $R_{ON}$  as a Function of  $V_S, V_D$  for Different Temperatures, 12 V Single Supply

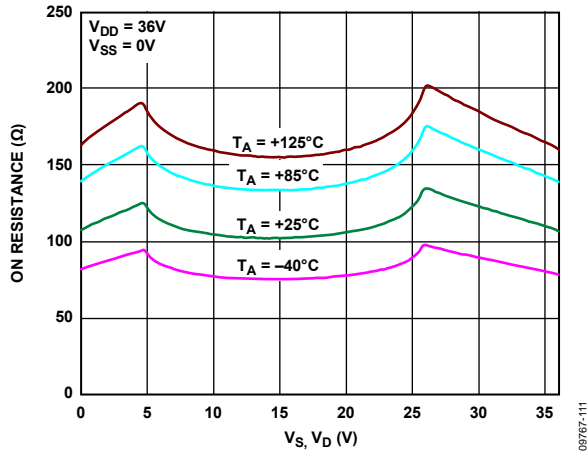

Figure 11.  $R_{ON}$  as a Function of  $V_S, V_D$  for Different Temperatures, 36 V Single Supply

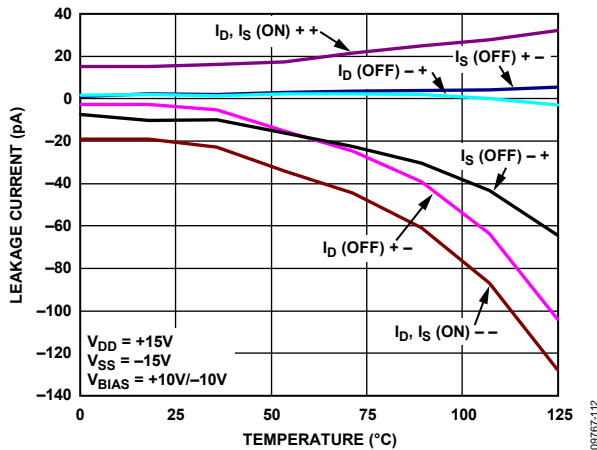

Figure 12. Leakage Currents vs. Temperature,  $\pm 15$  V Dual Supply

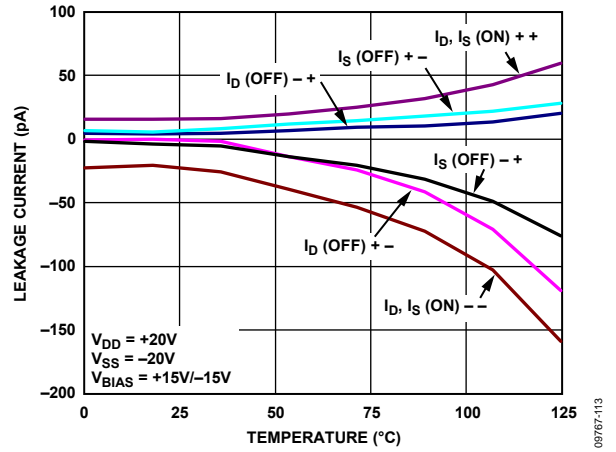

Figure 13. Leakage Currents vs. Temperature,  $\pm 20$  V Dual Supply

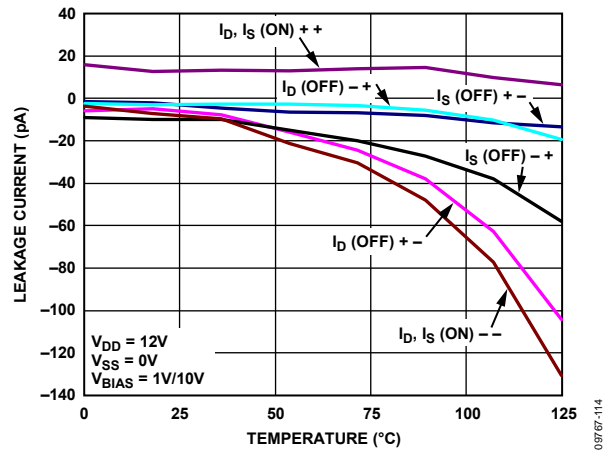

Figure 14. Leakage Currents vs. Temperature, 12 V Single Supply

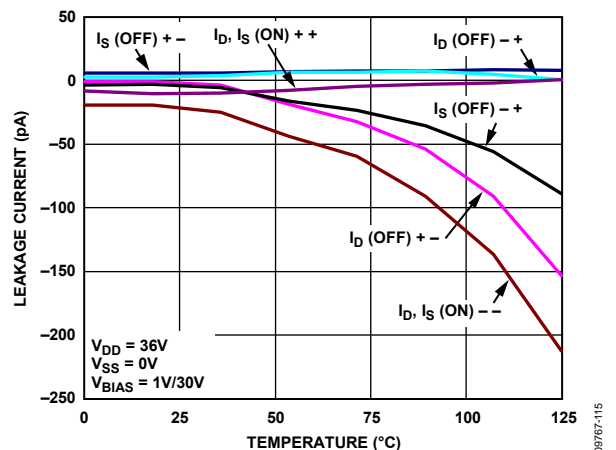

Figure 15. Leakage Currents vs. Temperature, 36 V Single Supply

# ADG5212/ADG5213

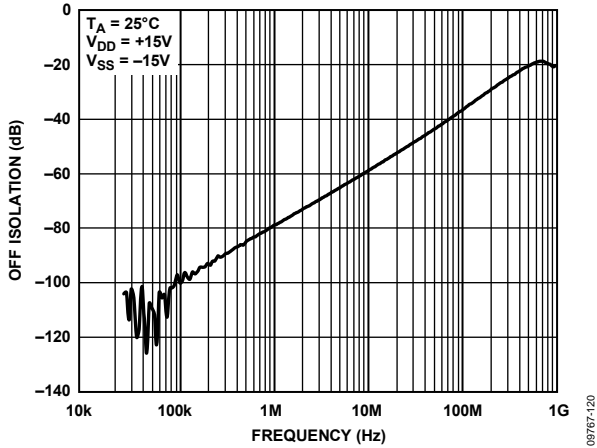

Figure 16. Off Isolation vs. Frequency,  $\pm 15$  V Dual Supply

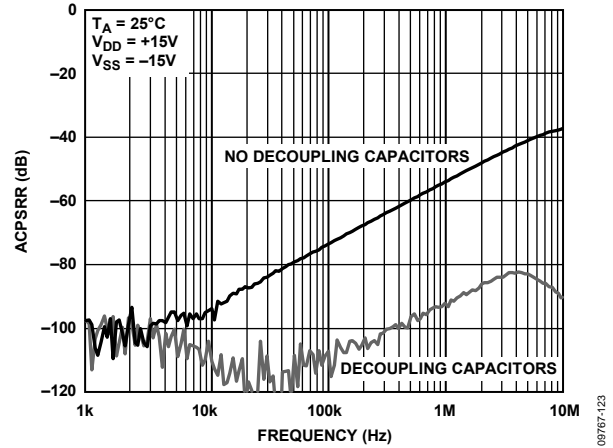

Figure 19. ACPSRR vs. Frequency,  $\pm 15$  V Dual Supply

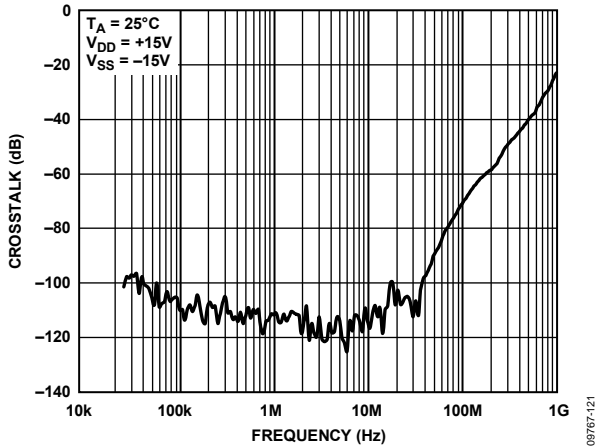

Figure 17. Crosstalk vs. Frequency,  $\pm 15$  V Dual Supply

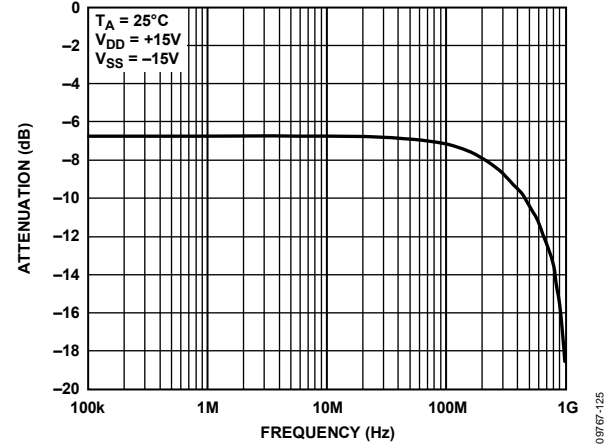

Figure 20. Bandwidth

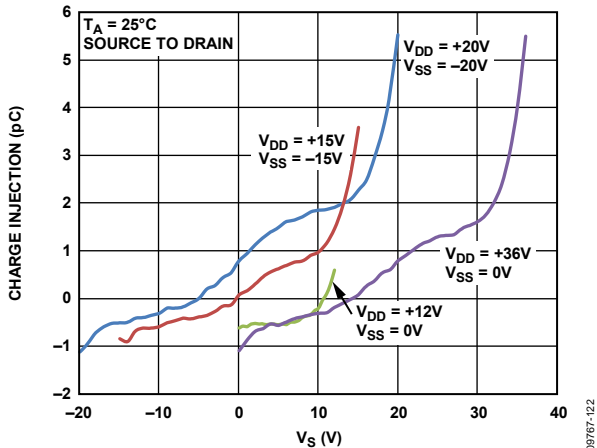

Figure 18. Charge Injection vs. Source Voltage

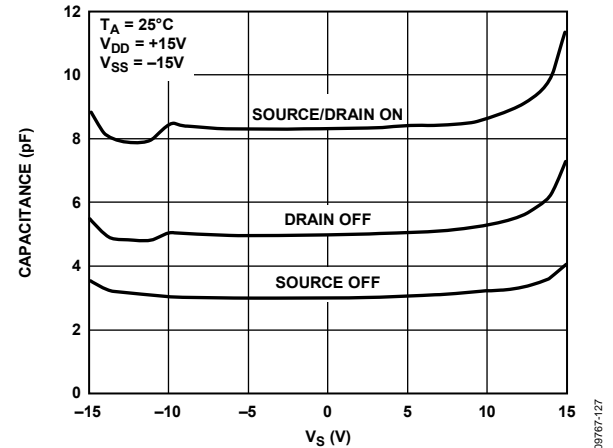

Figure 21. Capacitance

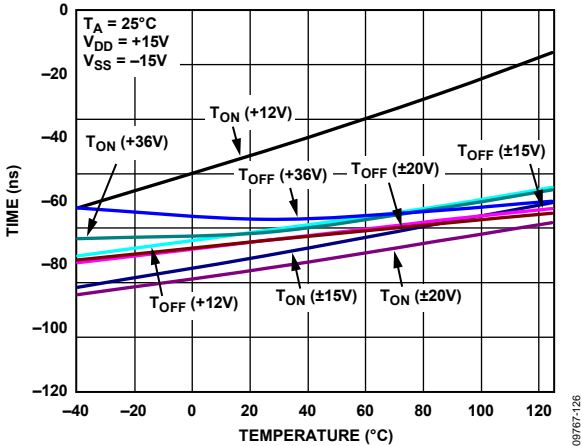

Figure 22.  $t_{ON}$ ,  $t_{OFF}$  Times vs. Temperature

09767-126

## TEST CIRCUITS

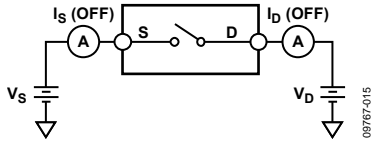

Figure 23. Off Leakage

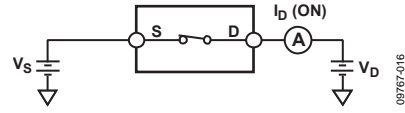

Figure 26. On Leakage

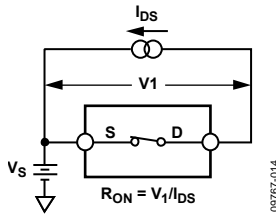

Figure 24. On Resistance

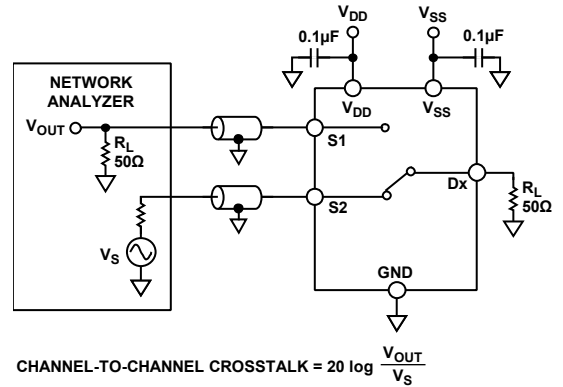

Figure 27. Channel-to-Channel Crosstalk

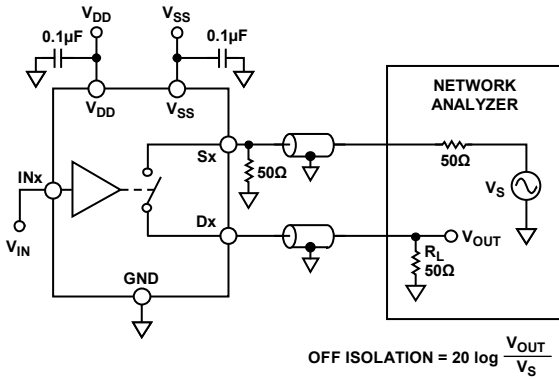

Figure 25. Off Isolation

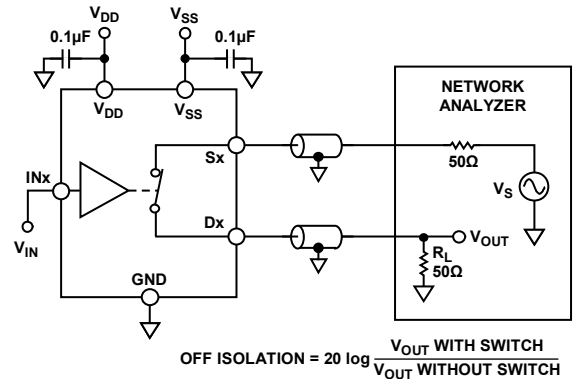

Figure 28. Bandwidth

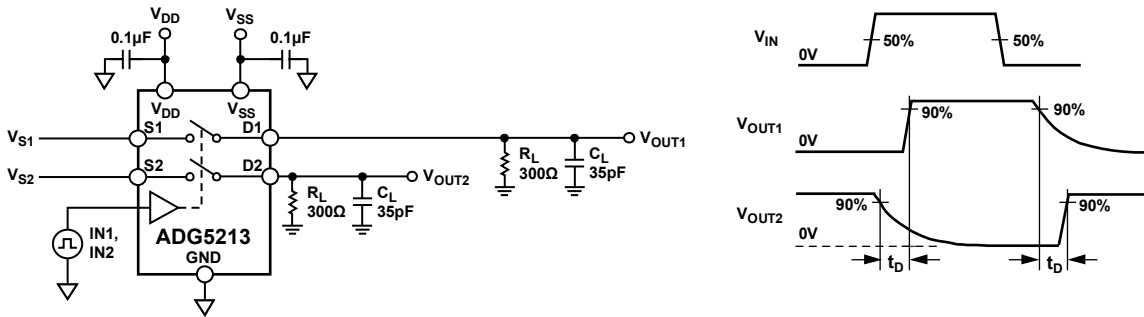

Figure 29. Break-Before-Make Time Delay,  $t_D$

09767-017

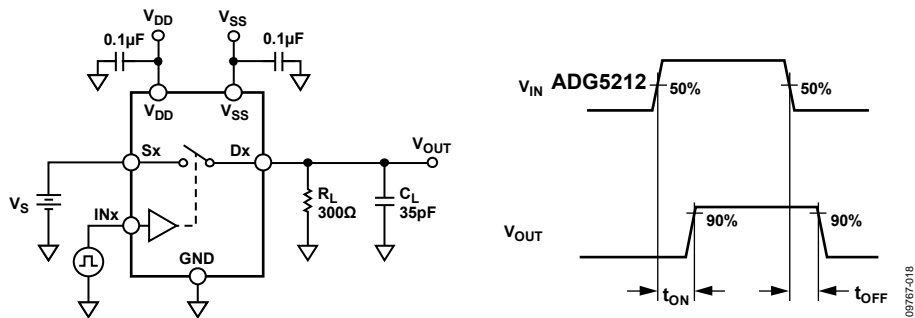

Figure 30. Switching Times

09767-018

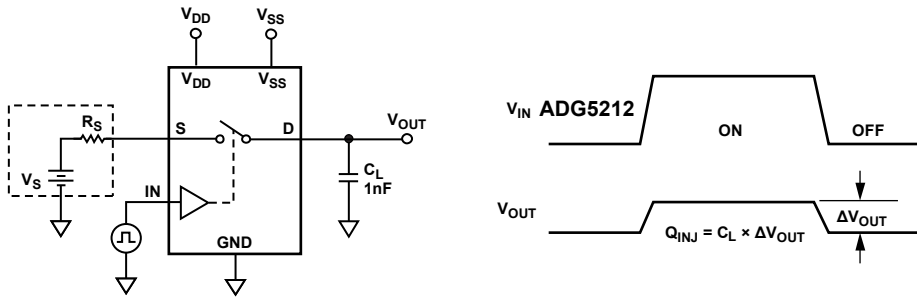

Figure 31. Charge Injection

09767-019

## TERMINOLOGY

### $I_{DD}$

$I_{DD}$  represents the positive supply current.

### $I_{SS}$

$I_{SS}$  represents the negative supply current.

### $V_D, V_S$

$V_D$  and  $V_S$  represent the analog voltage on Terminal Dx and Terminal Sx, respectively.

### $R_{ON}$

$R_{ON}$  represents the ohmic resistance between Terminal Dx and Terminal Sx.

### $\Delta R_{ON}$

$\Delta R_{ON}$  represents the difference between the  $R_{ON}$  of any two channels.

### $R_{FLAT(ON)}$

Flatness that is defined as the difference between the maximum and minimum value of on resistance measured over the specified analog signal range is represented by  $R_{FLAT(ON)}$ .

### $I_S$ (Off)

$I_S$  (Off) is the source leakage current with the switch off.

### $I_D$ (Off)

$I_D$  (Off) is the drain leakage current with the switch off.

### $I_D$ (On), $I_S$ (On)

$I_D$  (On) and  $I_S$  (On) represent the channel leakage currents with the switch on.

### $V_{INL}$

$V_{INL}$  is the maximum input voltage for Logic 0.

### $V_{INH}$

$V_{INH}$  is the minimum input voltage for Logic 1.

### $I_{INL}, I_{INH}$

$I_{INL}$  and  $I_{INH}$  represent the low and high input currents of the digital inputs.

### $C_D$ (Off)

$C_D$  (Off) represents the off switch drain capacitance, which is measured with reference to ground.

### $C_S$ (Off)

$C_S$  (Off) represents the off switch source capacitance, which is measured with reference to ground.

### $C_D$ (On), $C_S$ (On)

$C_D$  (On) and  $C_S$  (On) represent on switch capacitances, which are measured with reference to ground.

### $C_{IN}$

$C_{IN}$  is the digital input capacitance.

### $t_{ON}$

$t_{ON}$  represents the delay between applying the digital control input and the output switching on (see Figure 30).

### $t_{OFF}$

$t_{OFF}$  represents the delay between applying the digital control input and the output switching off (see Figure 30).

### $t_D$

$t_D$  represents the off time measured between the 80% point of both switches when switching from one address state to another.

### Off Isolation

Off isolation is a measure of unwanted signal coupling through an off switch.

### Charge Injection

Charge injection is a measure of the glitch impulse transferred from the digital input to the analog output during switching.

### Crosstalk

Crosstalk is a measure of unwanted signal that is coupled through from one channel to another as a result of parasitic capacitance.

### Bandwidth

Bandwidth is the frequency at which the output is attenuated by 3 dB.

### On Response

On response is the frequency response of the on switch.

### Insertion Loss

Insertion loss is the loss due to the on resistance of the switch.

### AC Power Supply Rejection Ratio (ACPSRR)

AC power supply rejection ratio (ACPSRR) is the ratio of the amplitude of signal on the output to the amplitude of the modulation. This is a measure of the ability of the device to avoid coupling noise and spurious signals that appear on the supply voltage pin to the output of the switch. The dc voltage on the device is modulated by a sine wave of 0.62 V p-p.

## TRENCH ISOLATION

In the ADG5212 and ADG5213, an insulating oxide layer (trench) is placed between the NMOS and the PMOS transistors of each CMOS switch. Parasitic junctions, which occur between the transistors in junction isolated switches, are eliminated, and the result is a completely latch-up proof switch.

In junction isolation, the N and P wells of the PMOS and NMOS transistors form a diode that is reverse-biased under normal operation. However, during overvoltage conditions, this diode can become forward-biased. A silicon controlled rectifier (SCR) type circuit is formed by the two transistors, causing a significant amplification of the current that, in turn, leads to latch-up. With trench isolation, this diode is removed and the result is a latch-up proof switch.

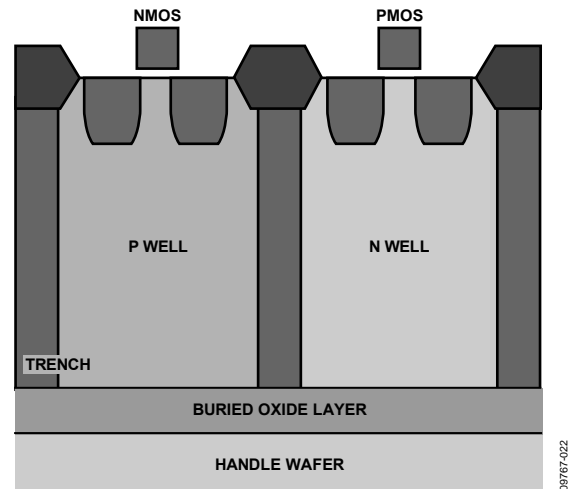

Figure 32. Trench Isolation

09767-022

## APPLICATIONS INFORMATION

The ADG52xx family of switches and multiplexers provides a robust solution for instrumentation, industrial, automotive, aerospace, and other harsh environments that are prone to latch-up, which is an undesirable high current state that can lead to device failure and persists until the power supply is turned off. The ADG5212/ADG5213 high voltage switches allow single-supply operation from 9 V to 40 V and dual-supply operation from  $\pm 9$  V to  $\pm 22$  V.

OUTLINE DIMENSIONS

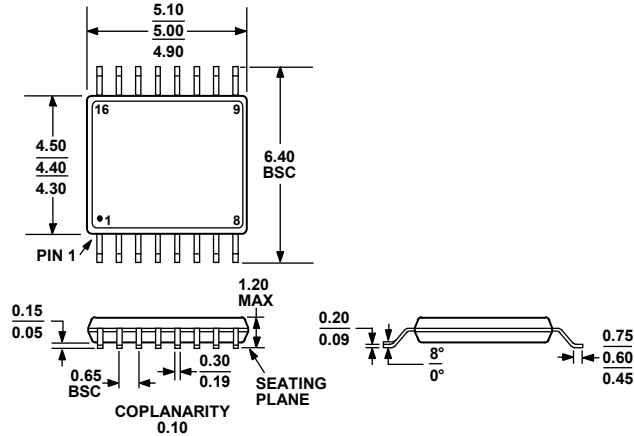

COMPLIANT TO JEDEC STANDARDS MO-153-AB

Figure 33. 16-Lead Thin Shrink Small Outline Package [TSSOP] (RU-16)

Dimensions shown in millimeters

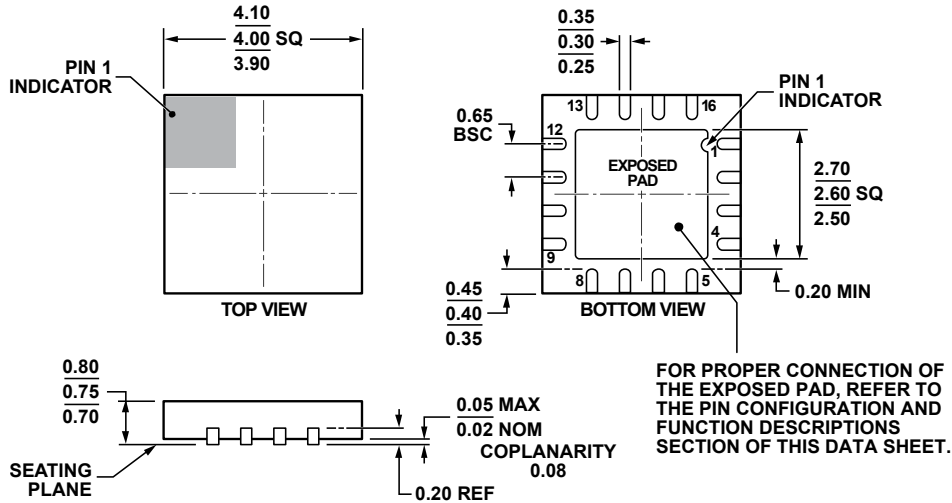

COMPLIANT TO JEDEC STANDARDS MO-220-WGGC.

Figure 34. 16-Lead Lead Frame Chip Scale Package [LFCSP\_VQ] 4 mm x 4 mm Body, Very Very Thin Quad (CP-16-17)

Dimensions shown in millimeters

08-16-2010-C

ORDERING GUIDE

Model <sup>1</sup>	Temperature Range	Package Description	Package Option
ADG5212BRUZ	-40°C to +125°C	16-Lead Thin Shrink Small Outline Package [TSSOP]	RU-16
ADG5212BRUZ-RL7	-40°C to +125°C	16-Lead Thin Shrink Small Outline Package [TSSOP]	RU-16
ADG5212BCPZ-RL7	-40°C to +125°C	16-Lead Lead Frame Chip Scale Package [LFCSP_VQ]	CP-16-17
ADG5213BRUZ	-40°C to +125°C	16-Lead Thin Shrink Small Outline Package [TSSOP]	RU-16
ADG5213BRUZ-RL7	-40°C to +125°C	16-Lead Thin Shrink Small Outline Package [TSSOP]	RU-16
ADG5213BCPZ-RL7	-40°C to +125°C	16-Lead Lead Frame Chip Scale Package [LFCSP_VQ]	CP-16-17

<sup>1</sup> Z = RoHS Compliant Part.

**NOTES**