



**MCP3425 SOT23-6
Evaluation Board
User's Guide**

Note the following details of the code protection feature on Microchip devices:

- Microchip products meet the specification contained in their particular Microchip Data Sheet.
- Microchip believes that its family of products is one of the most secure families of its kind on the market today, when used in the intended manner and under normal conditions.
- There are dishonest and possibly illegal methods used to breach the code protection feature. All of these methods, to our knowledge, require using the Microchip products in a manner outside the operating specifications contained in Microchip's Data Sheets. Most likely, the person doing so is engaged in theft of intellectual property.
- Microchip is willing to work with the customer who is concerned about the integrity of their code.
- Neither Microchip nor any other semiconductor manufacturer can guarantee the security of their code. Code protection does not mean that we are guaranteeing the product as "unbreakable."

Code protection is constantly evolving. We at Microchip are committed to continuously improving the code protection features of our products. Attempts to break Microchip's code protection feature may be a violation of the Digital Millennium Copyright Act. If such acts allow unauthorized access to your software or other copyrighted work, you may have a right to sue for relief under that Act.

Information contained in this publication regarding device applications and the like is provided only for your convenience and may be superseded by updates. It is your responsibility to ensure that your application meets with your specifications. MICROCHIP MAKES NO REPRESENTATIONS OR WARRANTIES OF ANY KIND WHETHER EXPRESS OR IMPLIED, WRITTEN OR ORAL, STATUTORY OR OTHERWISE, RELATED TO THE INFORMATION, INCLUDING BUT NOT LIMITED TO ITS CONDITION, QUALITY, PERFORMANCE, MERCHANTABILITY OR FITNESS FOR PURPOSE. Microchip disclaims all liability arising from this information and its use. Use of Microchip devices in life support and/or safety applications is entirely at the buyer's risk, and the buyer agrees to defend, indemnify and hold harmless Microchip from any and all damages, claims, suits, or expenses resulting from such use. No licenses are conveyed, implicitly or otherwise, under any Microchip intellectual property rights.

Trademarks

The Microchip name and logo, the Microchip logo, Accuron, dsPIC, KEELOQ, KEELOQ logo, MPLAB, PIC, PICmicro, PICSTART, rfPIC, SmartShunt and UNI/O are registered trademarks of Microchip Technology Incorporated in the U.S.A. and other countries.

FilterLab, Linear Active Thermistor, MXDEV, MXLAB, SEEVAL, SmartSensor and The Embedded Control Solutions Company are registered trademarks of Microchip Technology Incorporated in the U.S.A.

Analog-for-the-Digital Age, Application Maestro, CodeGuard, dsPICDEM, dsPICDEM.net, dsPICworks, dsSPEAK, ECAN, ECONOMONITOR, FanSense, In-Circuit Serial Programming, ICSP, ICEPIC, Mindi, MiWi, MPASM, MPLAB Certified logo, MPLIB, MPLINK, mTouch, PICkit, PICDEM, PICDEM.net, PICTail, PIC³² logo, PowerCal, PowerInfo, PowerMate, PowerTool, REAL ICE, rfLAB, Select Mode, Total Endurance, WiperLock and ZENA are trademarks of Microchip Technology Incorporated in the U.S.A. and other countries.

SQTP is a service mark of Microchip Technology Incorporated in the U.S.A.

All other trademarks mentioned herein are property of their respective companies.

© 2009, Microchip Technology Incorporated, Printed in the U.S.A., All Rights Reserved.

 Printed on recycled paper.

QUALITY MANAGEMENT SYSTEM
CERTIFIED BY DNV
== ISO/TS 16949:2002 ==

Microchip received ISO/TS-16949:2002 certification for its worldwide headquarters, design and wafer fabrication facilities in Chandler and Tempe, Arizona; Gresham, Oregon and design centers in California and India. The Company's quality system processes and procedures are for its PIC[®] MCUs and dsPIC[®] DSCs, KEELOQ[®] code hopping devices, Serial EEPROMs, microperipherals, nonvolatile memory and analog products. In addition, Microchip's quality system for the design and manufacture of development systems is ISO 9001:2000 certified.



MCP3425 SOT23-6 EVALUATION BOARD USER'S GUIDE

Table of Contents

Preface	1
Introduction.....	1
Document Layout	1
Conventions Used in this Guide	2
Recommended Reading.....	3
The Microchip Web Site	3
Customer Support	3
Document Revision History	4
Chapter 1. Quick Start Instructions	
1.1 Introduction	5
1.2 Description of the MCP3425 SOT23-6 Evaluation Board	5
1.3 Getting Started with PICKit™ Serial Analyzer	7
Appendix A. Schematic and Layouts	
A.1 Introduction	23
A.2 Board – Schematic	24
A.3 Board – Top Layer	25
A.4 Board – Top Metal Layer	26
A.5 Board – Bottom Layer	27
Appendix B. Bill Of Materials (BOM)	
Worldwide Sales and Service	30

MCP3425 SOT23-6 Evaluation Board User's Guide

NOTES:



MCP3425 SOT23-6 EVALUATION BOARD USER'S GUIDE

Preface

NOTICE TO CUSTOMERS

All documentation becomes dated, and this manual is no exception. Microchip tools and documentation are constantly evolving to meet customer needs, so some actual dialogs and/or tool descriptions may differ from those in this document. Please refer to our web site (www.microchip.com) to obtain the latest documentation available.

Documents are identified with a "DS" number. This number is located on the bottom of each page, in front of the page number. The numbering convention for the DS number is "DSXXXXA", where "XXXX" is the document number and "A" is the revision level of the document.

For the most up-to-date information on development tools, see the MPLAB® IDE on-line help. Select the Help menu, and then Topics to open a list of available on-line help files.

INTRODUCTION

This chapter contains general information that will be useful to know before using the MCP3425 SOT23-6 Evaluation Board. Items discussed in this chapter include:

- Document Layout
- Conventions Used in this Guide
- Recommended Reading
- The Microchip Web Site
- Customer Support
- Document Revision History

DOCUMENT LAYOUT

This document describes how to use the MCP3425 SOT23-6 Evaluation Board as a development tool to emulate and debug firmware on a target board. The manual layout is as follows:

- **Chapter 1. "Quick Start Instructions"** – this chapter provides an overview of the MCP3425 SOT23-6 Evaluation Board and instructions on how to program the DAC register and EEPROM of the MCP4725 device.
- **Appendix A. "Schematic and Layouts"** – shows the schematic and layout diagrams for the MCP3425 SOT23-6 Evaluation Board.
- **Appendix B. "Bill Of Materials (BOM)"** – lists the parts used to build the MCP3425 SOT23-6 Evaluation Board.

MCP3425 SOT23-6 Evaluation Board User's Guide

CONVENTIONS USED IN THIS GUIDE

This manual uses the following documentation conventions:

DOCUMENTATION CONVENTIONS

Description	Represents	Examples
Arial font:		
Italic characters	Referenced books	<i>MPLAB[®] IDE User's Guide</i>
	Emphasized text	...is the <i>only</i> compiler...
Initial caps	A window	the Output window
	A dialog	the Settings dialog
	A menu selection	select Enable Programmer
Quotes	A field name in a window or dialog	"Save project before build"
Underlined, italic text with right angle bracket	A menu path	<u><i>File>Save</i></u>
Bold characters	A dialog button	Click OK
	A tab	Click the Power tab
N'Rnnnn	A number in verilog format, where N is the total number of digits, R is the radix and n is a digit.	4'b0010, 2'hF1
Text in angle brackets < >	A key on the keyboard	Press <Enter>, <F1>
Courier New font:		
Plain Courier New	Sample source code	#define START
	Filenames	autoexec.bat
	File paths	c:\mcc18\h
	Keywords	_asm, _endasm, static
	Command-line options	-Opa+, -Opa-
	Bit values	0, 1
	Constants	0xFF, 'A'
Italic Courier New	A variable argument	<i>file.o</i> , where <i>file</i> can be any valid filename
Square brackets []	Optional arguments	mcc18 [options] <i>file</i> [options]
Curly brackets and pipe character: { }	Choice of mutually exclusive arguments; an OR selection	errorlevel {0 1}
Ellipses...	Replaces repeated text	var_name [, var_name...]
	Represents code supplied by user	void main (void) { ... }

RECOMMENDED READING

This user's guide describes how to use the MCP3425 SOT23-6 Evaluation Board with the PICkit Serial Analyzer. The following Microchip documents are available and recommended as supplemental reference resources.

PICkit™ Serial Analyzer User's Guide, DS51647

Consult this document for instructions on how to use the PICkit Serial Analyzer hardware and software.

MCP3425 Data Sheet, "16 bit Analog-to-Digital Converter with I²C Interface and On-Board Reference", DS22072

This data sheet provides detailed information regarding the MCP3425 product.

THE MICROCHIP WEB SITE

Microchip provides online support via our web site at www.microchip.com. This web site is used as a means to make files and information easily available to customers. Accessible by using your favorite Internet browser, the web site contains the following information:

- **Product Support** – Data sheets and errata, application notes and sample programs, design resources, user's guides and hardware support documents, latest software releases and archived software
- **General Technical Support** – Frequently Asked Questions (FAQs), technical support requests, online discussion groups, Microchip consultant program member listing
- **Business of Microchip** – Product selector and ordering guides, latest Microchip press releases, listing of seminars and events, listings of Microchip sales offices, distributors and factory representatives

CUSTOMER SUPPORT

Users of Microchip products can receive assistance through several channels:

- Distributor or Representative
- Local Sales Office
- Field Application Engineer (FAE)
- Technical Support

Customers should contact their distributor, representative or field application engineer (FAE) for support. Local sales offices are also available to help customers. A listing of sales offices and locations is included in the back of this document.

Technical support is available through the web site at: <http://support.microchip.com>

MCP3425 SOT23-6 Evaluation Board User's Guide

DOCUMENT REVISION HISTORY

Revision A (January 2009)

- Initial Release of this Document.

Chapter 1. Quick Start Instructions

1.1 INTRODUCTION

The following sections provide an overview of the MCP3425 SOT23-6 Evaluation Board and demonstrate how to use it with the PICKit™ Serial Analyzer (P/N: DV164122).

The following topics are covered:

- Description of the MCP3425 SOT23-6 Evaluation Board
- Using MCP3425 SOT23-6 Evaluation Board with the PICKit Serial Analyzer to evaluate the MCP3425 device.

1.2 DESCRIPTION OF THE MCP3425 SOT23-6 EVALUATION BOARD

The MCP3425 SOT23-6 Evaluation Board (P/N MCP3425EV) contains a MCP3425 16-bit Delta-Sigma Analog-to-Digital Converter (ADC). The MCP3425 is an 16-bit single channel ADC device with various options. The MCP3425 SOT23-6 Evaluation Board has analog input connection pads and V_{DD} , SDA, and SCL test pads. The user can connect any sensor input signal to this evaluation board and test the ADC conversion results. The PICKit Serial Analyzer's PC graphic user interface (GUI) provides the user's interface for configuration register bits of the MCP3425 and displays the ADC conversion values. The PICKit Serial Analyzer links between the GUI and the MCP3425 SOT23-6 Evaluation Board and provides the I²C communication to the MCP3425 SOT23-6 Evaluation Board. The user also can use this MCP3425 SOT23-6 Evaluation Board without the PICKit Serial Analyzer by providing the I²C communication signal to the SDA and SCL test pads on the board.

This evaluation board has the following interfaces:

- PICKit Serial Analyzer (P/N: DV164122) for writing configuration register bits and reading the conversion data.

Note: The user can use this board without the PICKit Serial Analyzer as long as the V_{DD} , SCL, and SDA are provided to the board. This evaluation board does not include MCU.

The user can monitor the I²C communications by connecting an oscilloscope to the SDA and SCL test pads. Refer to **Appendix A. "Schematic and Layouts"**.

MCP3425 SOT23-6 Evaluation Board User's Guide

1.2.1 I²C Address Bits

The I²C device code and address bits of the MCP3425 device in this evaluation board are pre-programmed at factory (Code: 1101000).

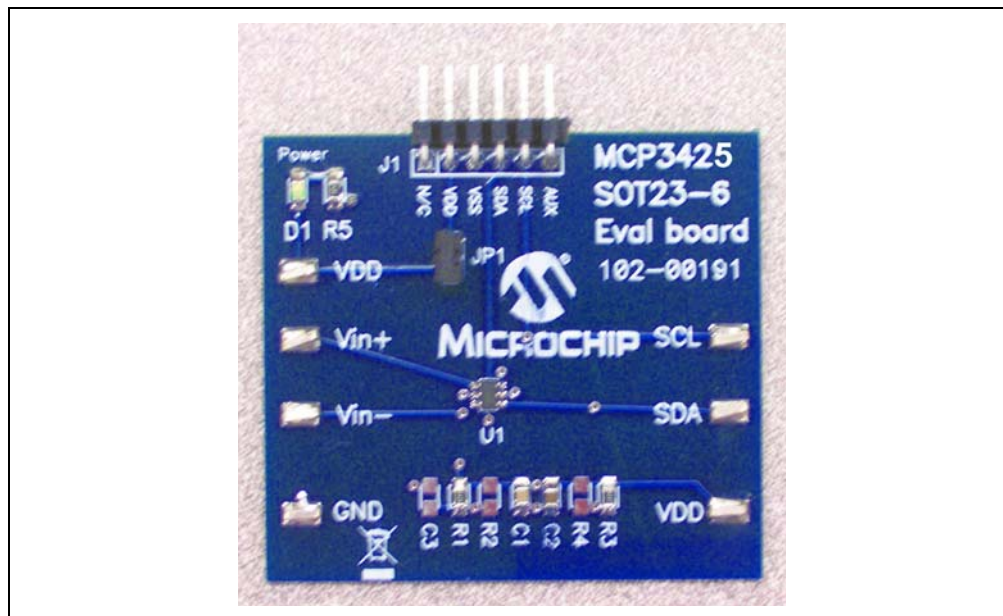

FIGURE 1-1: Front and Back Views of the MCP3425 SOT23-6 Evaluation Board.

1.3 GETTING STARTED WITH PICKIT™ SERIAL ANALYZER

Figure 1-1 shows the MCP3425 SOT23-6 Evaluation Board, while Figure 1-2 shows the evaluation board and the PICKit Serial Analyzer connection.

The following instructions show how to use them together:

1. Connect the MCP3425 SOT23-6 Evaluation Board's J1 pin socket to the PICKit Serial Analyzer, as shown in Figure 1-2.
2. Connect oscilloscope probes to SCL and SDA test pins (optional).
3. V_{DD} selection: You can use the V_{DD} from the PICKit Serial Analyzer or your own external V_{DD} . You can select the V_{DD} path using the JP1 connector:
 - (a) Connect JP1, if using V_{DD} from PICKit Serial Analyzer.
 - (b) Disconnect JP1 and apply V_{DD} at the V_{DD} pad, if you are using external V_{DD} .

Note: If you are using external V_{DD} , connect the external V_{DD} at V_{DD} pad.

4. Connect V_{DD} , if external V_{DD} is used.

Note: Do not connect V_{DD} if you are using the V_{DD} from the PICKit Serial Analyzer. The PICKit Serial Analyzer provides the V_{DD} automatically if it is connected to the PC.

5. LED D1 is turned on when V_{DD} is applied.

Note: If the V_{DD} is provided from the PICKit Serial Analyzer, then the LED may not be turned on until you execute a command. See **Section 1.3.2.1 "Creating a Script File for Configuration Byte Writing"** for executing the I²C command.

6. **Connecting analog inputs:** If you need to measure single-ended input, connect the unused pin (for example, V_{IN-}) to V_{SS} .
7. Use the PICKit Serial Analyzer PC GUI to send I²C write and read commands. See **Section 1.3.2.1 "Creating a Script File for Configuration Byte Writing"**
8. Execute the PICKit Serial Analyzer Script file and obtain the ADC conversion results. The conversion results appear on the PICKit Serial Analyzer PC GUI. You can also observe the conversion results using the oscilloscope.

CAUTION

The analog input pin has ESD diodes. Certain input conditions can damage the device. Please pay attention to the following conditions:

- (a) Do not apply input greater than the input range specified by the MCP3425 data sheet.
- (b) Apply input signal after the V_{DD} is powered-up.

MCP3425 SOT23-6 Evaluation Board User's Guide

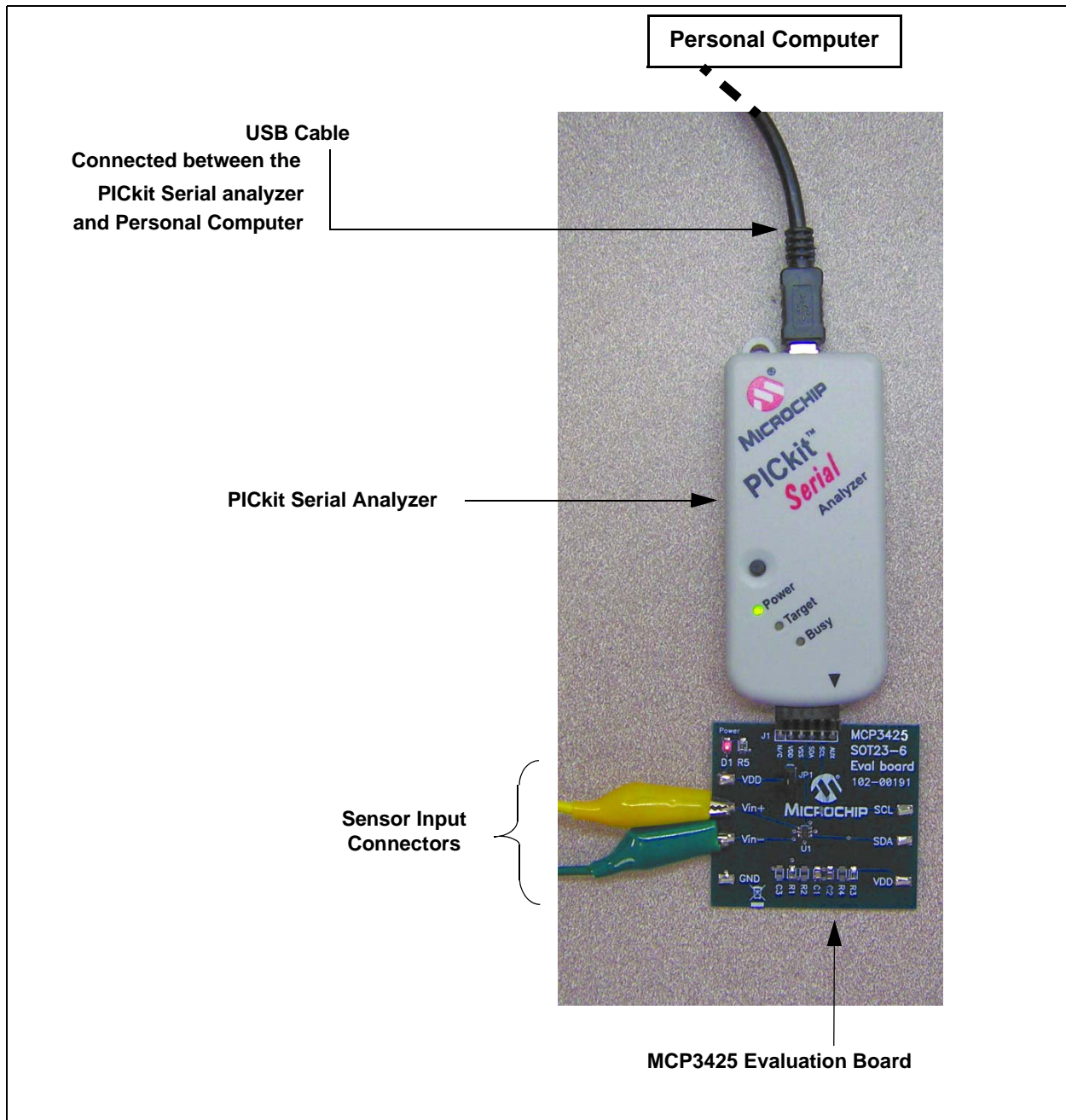

FIGURE 1-2: MCP3425 SOT23-6 Evaluation Board with the PICkit™ Serial Analyzer.

1.3.1 PICkit™ Serial Analyzer PC Software Set-Up for the MCP3425 Evaluation Board

The following steps describe how to set up and use the PICkit Serial Analyzer PC Graphic User Interface (GUI) to write the configuration bits of the MCP3425 on the MCP3425 SOT23-6 Evaluation Board and read the ADC conversion results.

1. Install the PICkit Serial Analyzer software onto your personal computer (PC).
2. Connect the USB cable between the PICkit Serial Analyzer and your PC.
3. Run the PICkit Serial PC Software; the following graphic user interface (GUI) will appear. Click the **Next** button and follow the instructions.

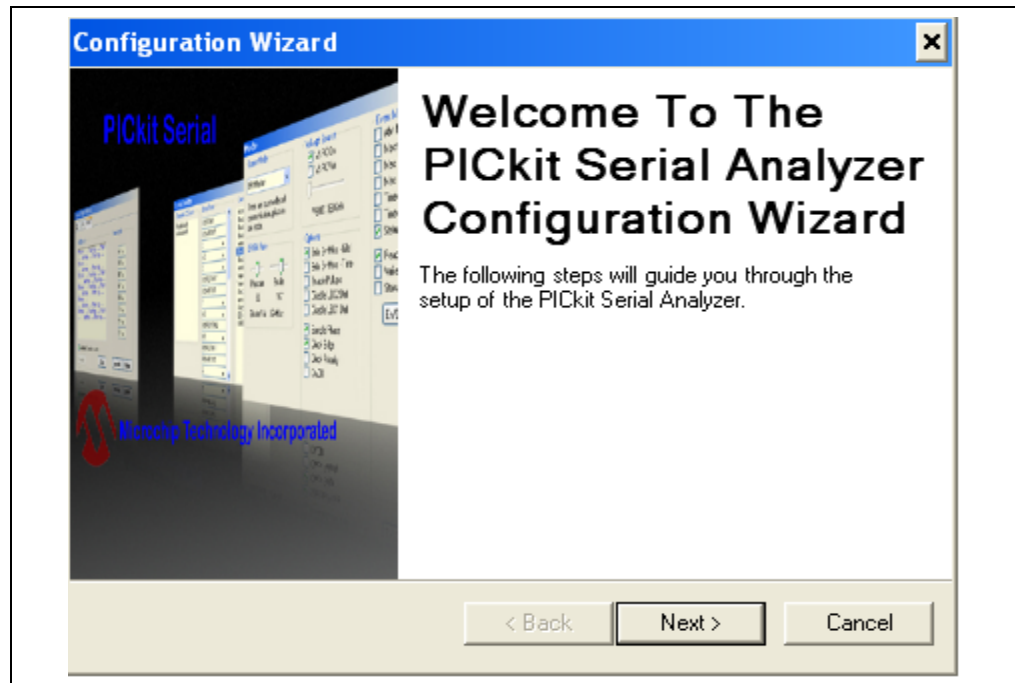

FIGURE 1-3: PICkit Serial Analyzer Configuration Wizard Welcome Window.

4. Select the Communication Mode type: I²C Master, and click the **Next** button.

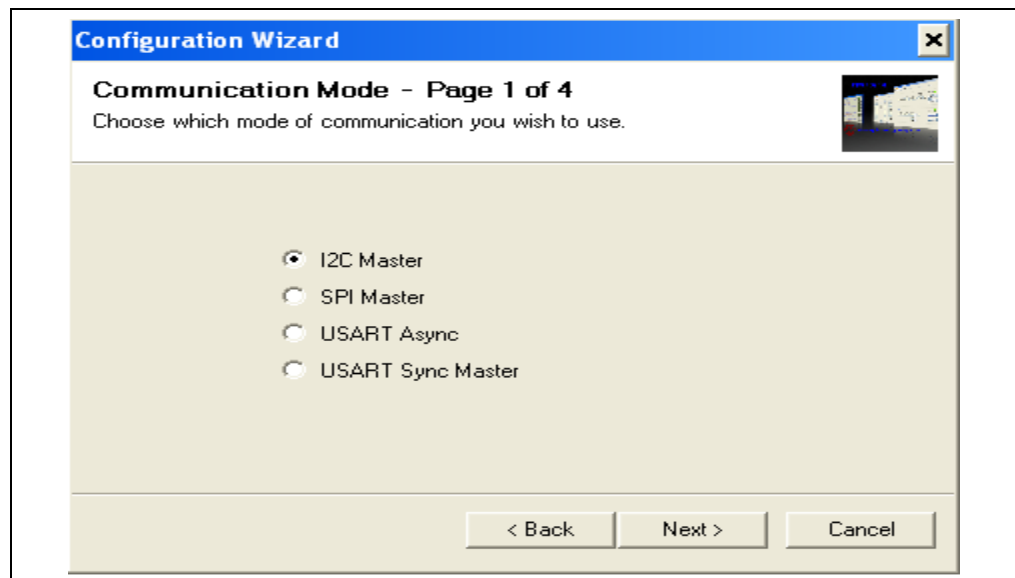

FIGURE 1-4: Step 1 - Communication Mode Selection.

MCP3425 SOT23-6 Evaluation Board User's Guide

5. Select 100 kHz or 400 kHz. Either one will be fine. Click the **Next** button.

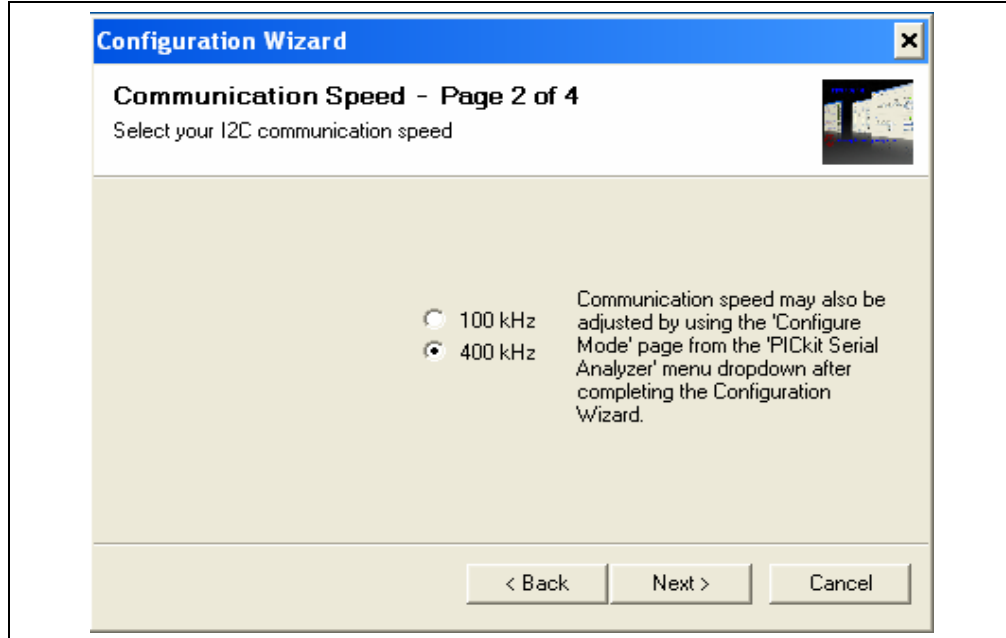

FIGURE 1-5: Step 2 - I²C Communication Speed Window.

Note: The MCP3425 device supports the I²C bus data rate up to 3.4 MHz, but the current version of the PICkit Serial Analyzer supports the I²C bus data rate up to 400 kHz only.

6. Select No on Enable Pull-ups and click the **Next** button.

Note: The MCP3425 SOT23-6 Evaluation Board has its own pull-up resistors.

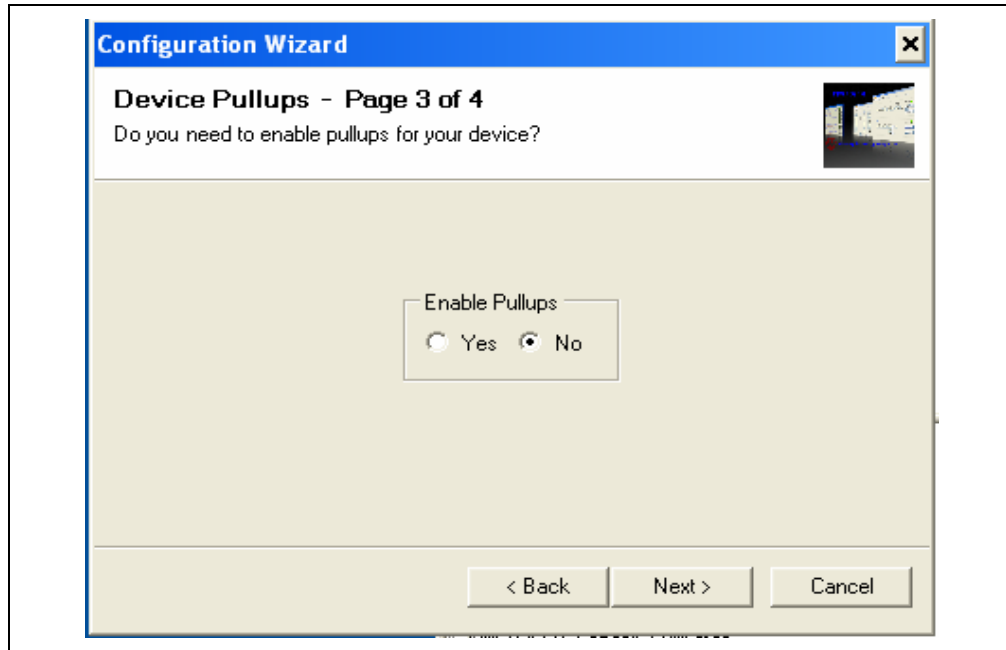

FIGURE 1-6: Step 3 - Device Pullups Window.

7. Select the V_{DD} voltage of the MCP3425 SOT23-6 Evaluation Board and click the **Next** button.

Case 1: When you use V_{DD} from the PICkit Serial Analyzer:

If you choose **PICkit Serial will power my device** and **5 Volt** as shown below, the MCP3425 SOT23-6 Evaluation Board is powered by the 5V DC from the PICkit Serial Analyzer through the JP1 jumper. In this case, make sure that the JP1 jumper on the MCP3425 SOT23-6 Evaluation Board is connected.

Case 2: When you use your own V_{DD} :

You can also provide your own V_{DD} voltage by applying a V_{DD} voltage at V_{DD} test point on the board. In this case, make sure that the JP1 jumper is disconnected.

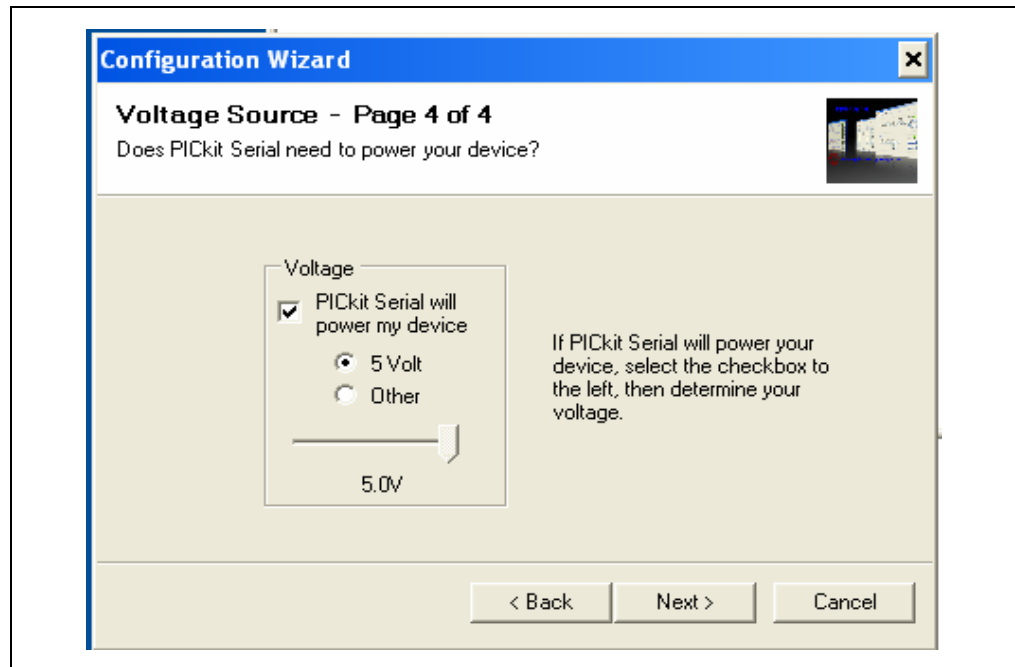

FIGURE 1-7: Step 4 - Voltage Source Selection Window.

MCP3425 SOT23-6 Evaluation Board User's Guide

- Click the **OK** button. You have made all of the PICkit Serial Analyzer Configuration Set-ups. You are now ready to program the MCP3425 SOT23-6 Evaluation Board using the PICkit Serial Analyzer.

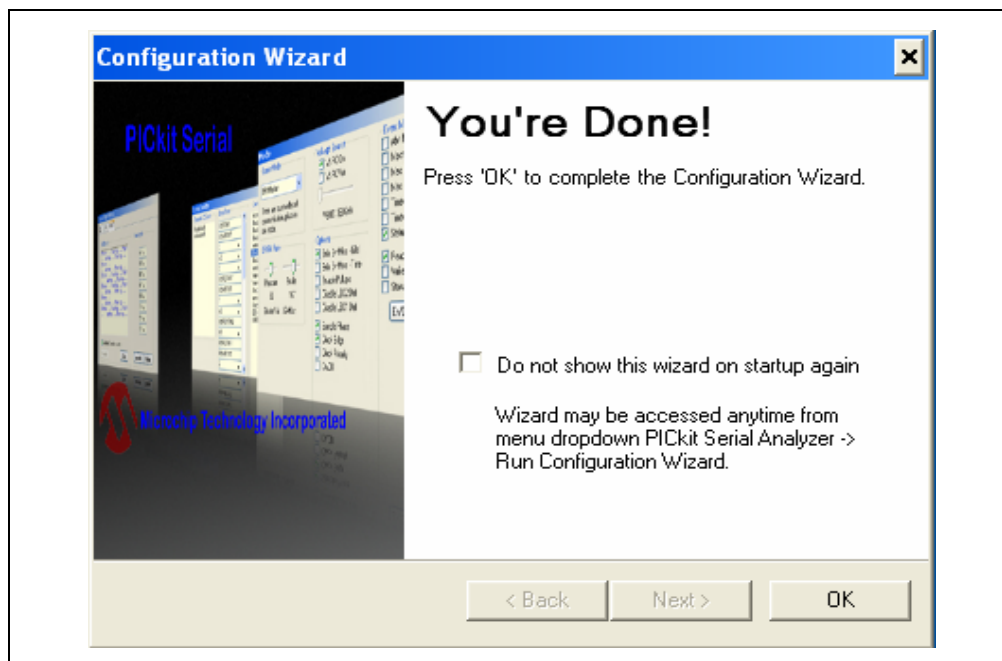

FIGURE 1-8: Configuration Wizard - Finishing Step.

1.3.2 Creating Script Files

In order to make a communication between the PICKit Serial Analyzer and the MCP3425 SOT23-6 Evaluation Board, a script file is needed. The following procedure shows how to create script files and how to use them.

- Select **Communication -> Script -> Script Builder**.

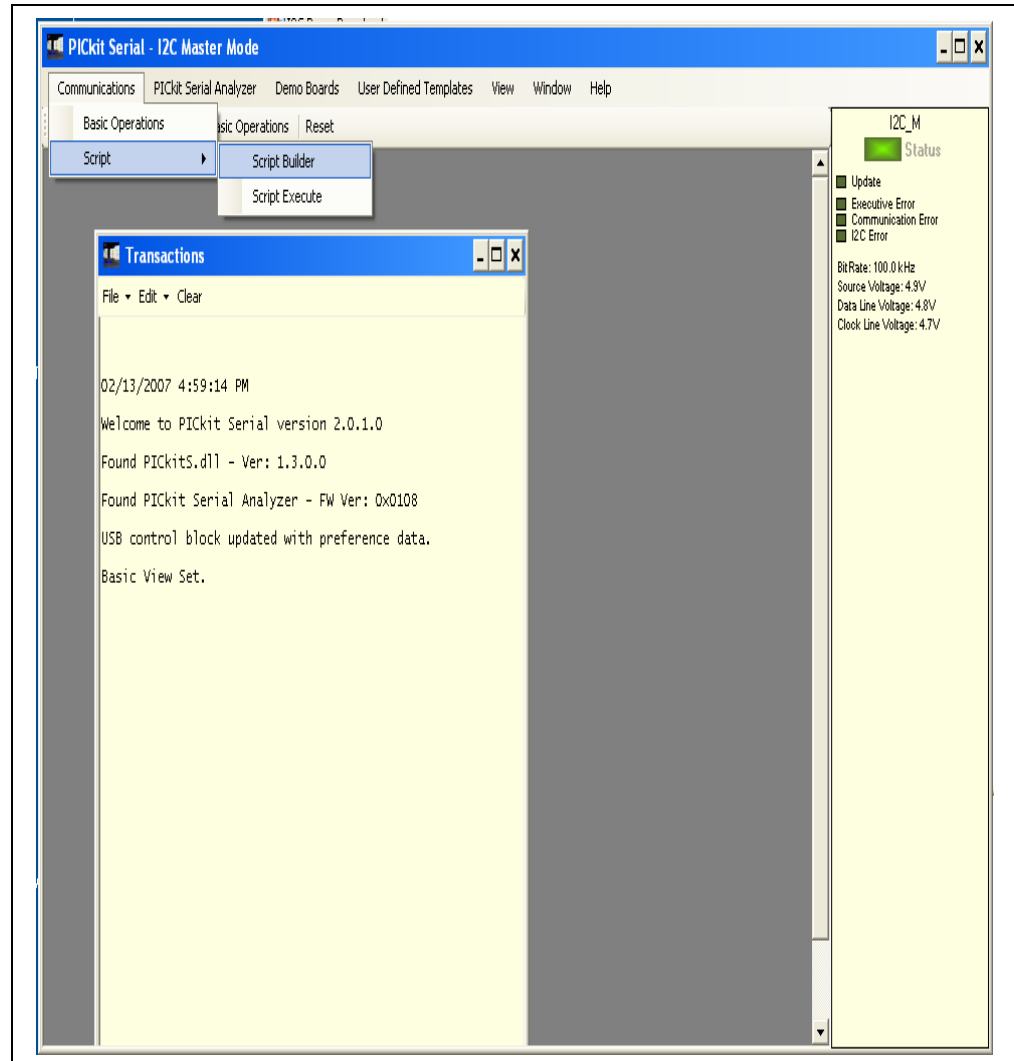

FIGURE 1-9: *Creating a Script File with Script Builder.*

MCP3425 SOT23-6 Evaluation Board User's Guide

1.3.2.1 CREATING A SCRIPT FILE FOR CONFIGURATION BYTE WRITING

1. Click on **WriteBlockAddrA8** in "Example I²C Scripts" column.
 - This will result in filling in the spaces under **Script Detail** column.
- Now you can modify the **Script Detail** column parameters by clicking with the right mouse button.

Modifying the Script Details parameters:

1. Under the Script Detail box, select the item in the parameter box.
2. Right click the mouse button and an option box appears to the right of your selection. This gives you the options that are available for the parameter selected.
3. Select the desired options (delete or insert the parameter box).
4. Keep the parameters in the same order as shown in the image below:

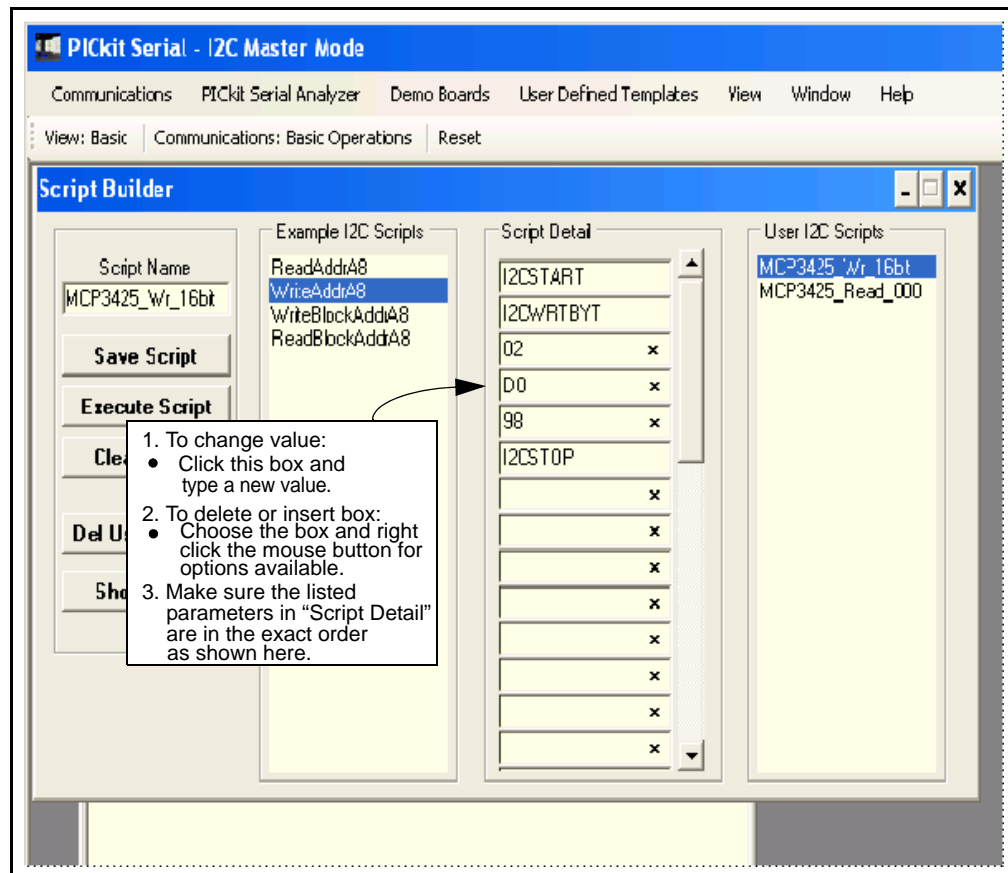

FIGURE 1-10: Modifying Parameters in the Script Builder Window.

5. Change the parameter value.

Script Detail	
I2CSTART	*
I2CWRTBYT	*
02	-----> This means there are two bytes to send
D0	-----> 1st Write Byte: Address byte with W/R bit = 1101-0000
98	-----> 2nd Write Byte: Configuration byte = 1001-1000
I2CSTOP	*

Note: All 6 parameters above must be listed in the same order as shown here. The parameters above with * are not modifiable. Address bits (A2, A1, A0) = (0,0,0) for this evaluation board. See the MCP3425 Data Sheet for more information on address bit selection.

MCP3425 SOT23-6 Evaluation Board User's Guide

PICKit Serial - I2C Master Mode

Communications PICKit Serial Analyzer Demo Boards User Defined Templates View Window Help

View: Basic | Communications: Basic Operations | Reset

Script Builder

Script Name: MCP3425_Wr_16bit

Buttons: Save Script, Execute Script, Clear Script, Del User Scripts, Show Array

Example I2C Scripts: ReadAddrA8, WriteAddrA8, WriteBlockAddrA8, ReadBlockAddrA8

Script Detail:

I2CSTART	
I2CWRTBYT	
02	x
D0	x
98	x
I2CSTOP	
	x
	x
	x
	x
	x
	x
	x
	x
	x

User I2C Scripts: MCP3425_Wr_16bit, MCP3425_Read_000

5:41:19 PM Sent script from Script Builder page, 9 bytes:

```
[S_] [W_] [02] [D0] [98] [P_]
[S_] [P_]
```

Note the 98 in the configuration byte selects the following options:

- Conversion Mode: Continuous Conversion
- Bit Resolution: 16 bits
- Gain Selection: 1x

FIGURE 1-11: Script File Example for the I²C Write Command.

1.3.2.2 SAVING THE SCRIPT FILE AND PROGRAMMING THE CONFIGURATION REGISTER

1. Change the 2nd and 3rd data bytes you want in the Script Detail.
2. Type in any script name (i.e., MCP3425_Wr_16Bit) in the space below the **Script Name** menu.
3. Click **Save Script** button.
4. Click **Execute Script** button.

Note: At this point, the PICKit Serial transmits the I²C Write command to the MCP3425 device. The saved file name will appear in **Users I2C Scripts** column, and can be re-used any time by selecting the file name.

5. You can also see the SCL and SDA waveforms using the oscilloscope.

Note: When you click on the “Execute Script” menu, the “Busy” LED on the PICKit Serial Analyzer will momentarily turn on and then turn off. If the LED remains ON, a communications problem has occurred. Remove the PICKit Serial Analyzer from your computer and recheck the parameter values in the order of parameters under the “Script Detail” column. Try again until the “Busy” LED goes OFF immediately after executing the write command.

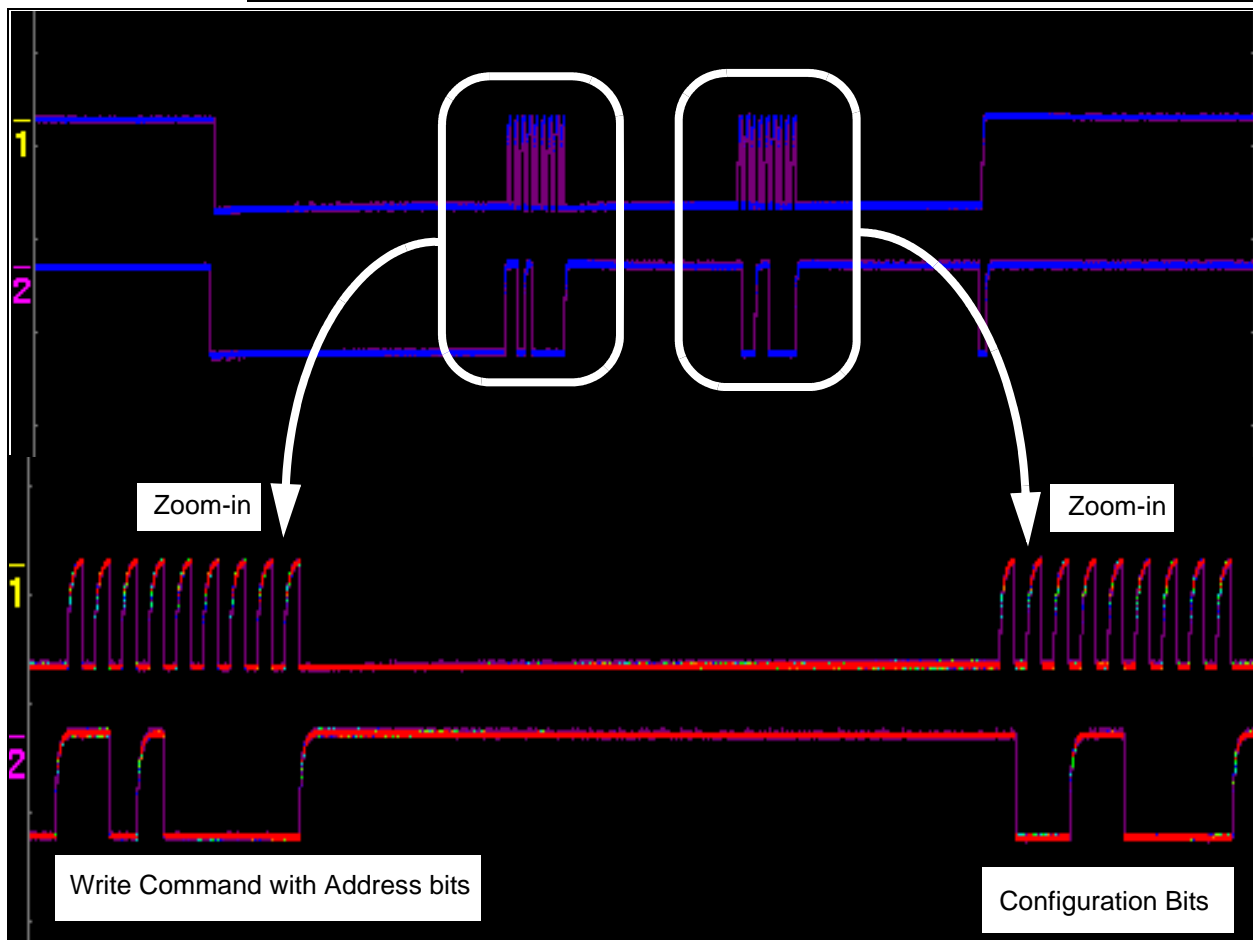

FIGURE 1-12: I²C Write Command Waveforms for the MCP3425.

MCP3425 SOT23-6 Evaluation Board User's Guide

1.3.3 Reading the Conversion Data using the PICkit Serial Analyzer

You can read back the conversion data with the following steps.

1.3.3.1 CREATING A SCRIPT FILE TO READ CONVERSION DATA

1. Click on **ReadAddrA8** in "Example I2C Scripts" column.
 - This will result in filling in the spaces under the **Script Detail** column. Now you can modify the parameter boxes (delete or insert) in the **Script Detail** column with options. The list of options will appear if you click the right mouse button at the parameter box. You can delete the parameter box or add a new one.
 - Make sure the "Script Detail" parameters are listed in order, as following:

Script Detail	
I2CSTART	*
I2CWRTBYT	*
01	-----> This means there <u>is</u> one byte to send for address
D1	-----> Address byte with \overline{W} /R bit = 1101-0001
I2CRDBYTNLB	*
4	-----> 4 bytes to read
I2CSTOP	*

Note: All 7 parameters above must be listed in the same order as shown here. The parameters above with * are not modifiable. Address bits (A2, A1, A0) = (0,0,0) for the MCP3425 SOT23-6 Evaluation Board. See the MCP3425 Data Sheet for more information on address bit selections.

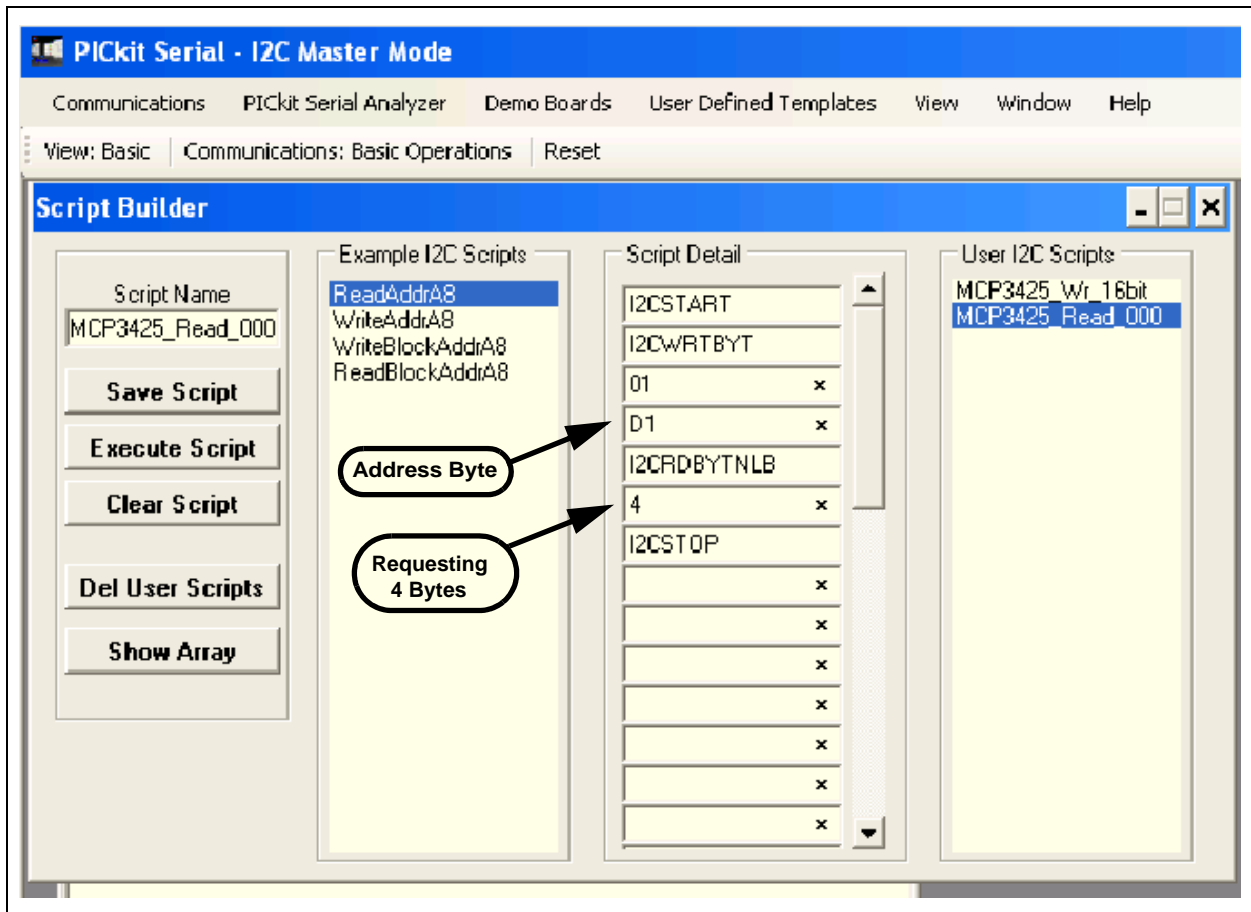

FIGURE 1-13: Script File Sample to Read Conversion Data.

2. Type in any script name (i.e., MCP3425_Read) in the space below the **Script Name** menu.
3. Click **Save Script** button.
4. Click **Execute Script** button.

Note: At this point, the PICkit Serial transmits the I²C Read Command to the MCP3425 device. The saved file name will appear in **Users I2C Scripts** column, and can be re-used any time by selecting the file name.

5. You can also see the SCL and SDA waveforms using the oscilloscope.

Note: When you click on the “Execute Script” menu, the “Busy” LED on the PICkit Serial Analyzer will momentarily turn on and then turn off. If the LED remains ON, a communications problem has occurred. Remove the PICkit Serial Analyzer from your computer and recheck the parameter values in the order of parameters under the “Script Detail” column. Try again until the “Busy” LED goes OFF immediately after executing the read command.

MCP3425 SOT23-6 Evaluation Board User's Guide

PICKit Serial - I2C Master Mode

Communications PICKit Serial Analyzer Demo Boards User Defined Templates View Window Help

View: Basic Communications: Basic Operations Reset

Script Builder

Script Name: MCP3425_Read_000

Save Script Execute Script Clear Script Del User Scripts Show Array

Example I2C Scripts: ReadAddrA8 WriteAddrA8 WriteBlockAddrA8 ReadBlockAddrA8

Script Detail:

I2CSTART	
I2CWRTBYT	
01	x
D1	x
I2CRDDBYTNLB	
4	x
I2CSTOP	
	x
	x
	x
	x
	x
	x
	x

User I2C Scripts: MCP3425 Wr 16bit MCP3425 Read_000

5:16:13 PM Sent script from Script Builder page, 10 bytes:

[S_] [W_] [01] [D1] [RN] [04] [P_] [S_] [1F] [50] [18] [98] [P_] **Reading Conversion Data**

4th Byte: Repeated Byte for Configuration byte (note that RDY bit returned to "1" after 4th byte)

3rd byte: Configuration Byte (note that RDYbit is "0")

2nd byte: Data Byte

1st byte: Data Byte

Results:

Output code: 1F50 in hex (= 8016 in decimal)

Output Voltage: 8016 x 62.5 μV (LSB) = 0.501V

Note:

- * 1 LSB for 16 bit = 62.6 μV
- * Input at CH1 = 0.501V

FIGURE 1-14: Reading Conversion Results: Note that the Input = 0.501V is applied at Ch.1. The reading indicates the measured value is 0.501V. See Figure 1-15 for waveforms.

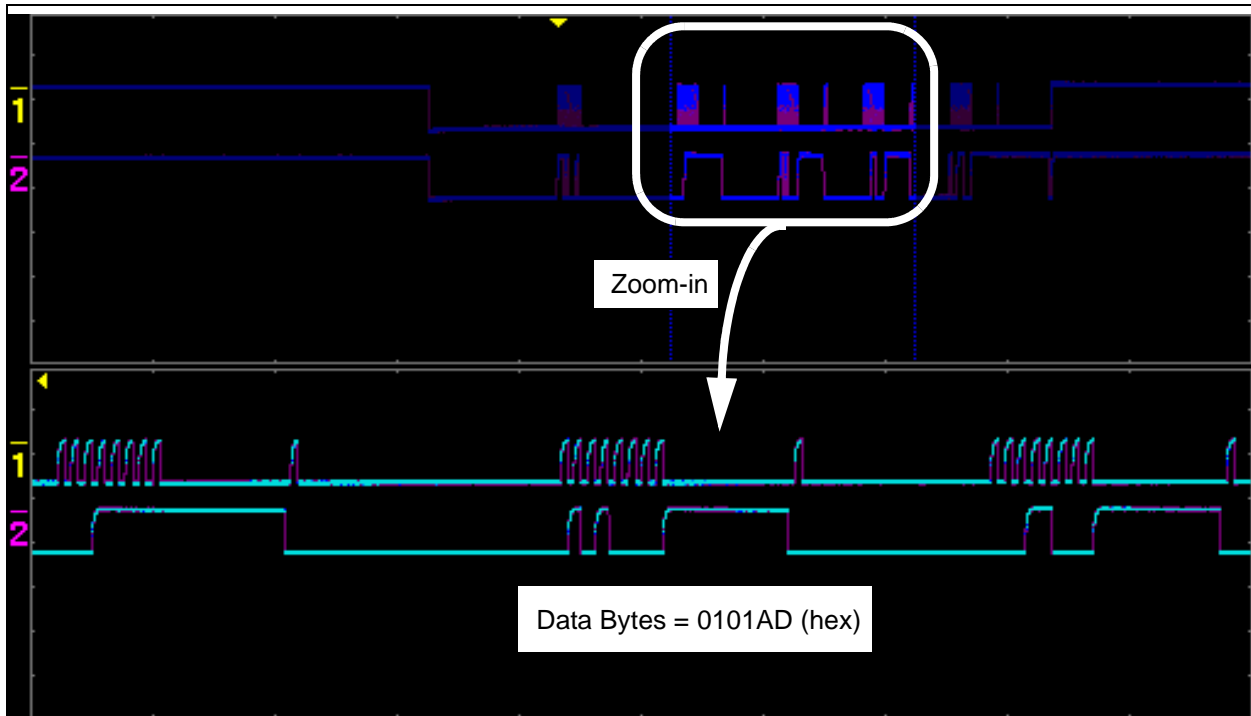

(a) Read command and outputs. The 3 data bytes are zoomed in for better clarity.

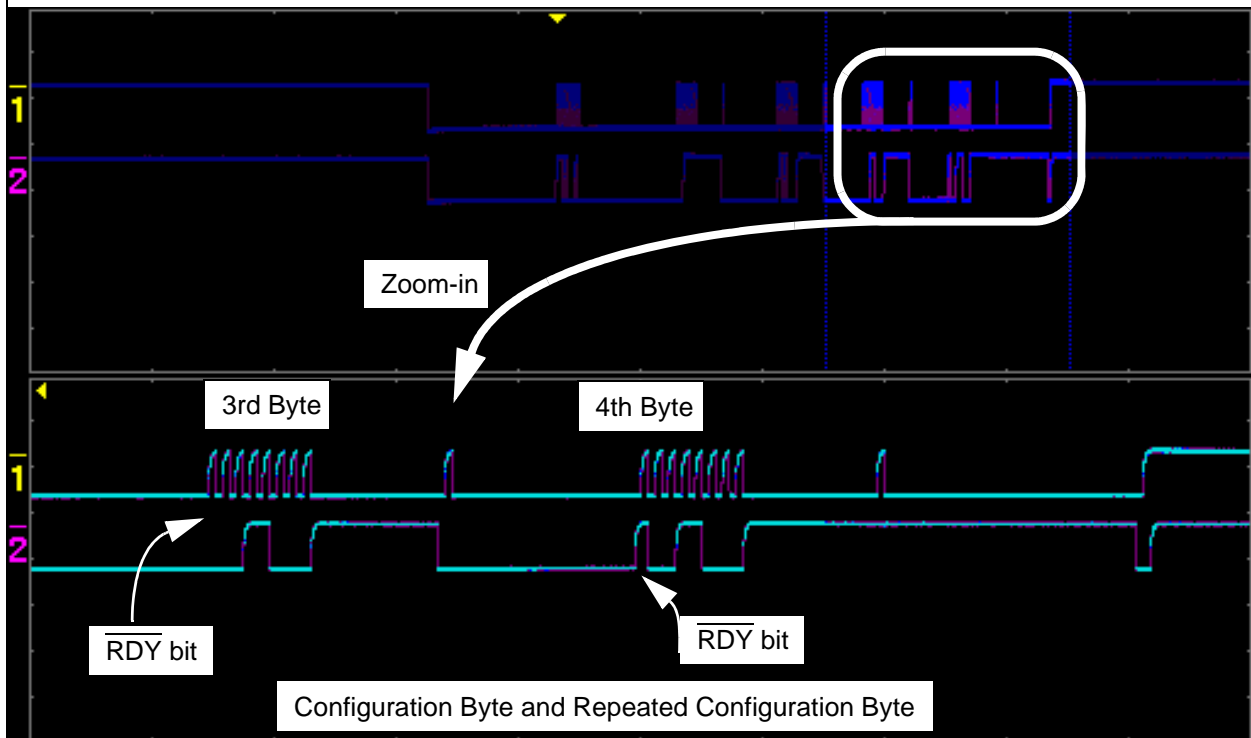

(b) Read command and outputs. The last two data bytes are zoomed in for better clarity.

FIGURE 1-15: Read Command and Data on I^2C bus. Note the \overline{RDY} bit in 3rd byte is "0". This means the conversion data just read is the latest conversion data. After the \overline{RDY} bit is read out at the 3rd byte, the \overline{RDY} bit becomes now "1" in the 4th byte (repeated byte). This means the device is now in the process of a new conversion and the latest conversion result is not ready yet.

MCP3425 SOT23-6 Evaluation Board User's Guide

NOTES:



MCP3425 SOT23-6 EVALUATION BOARD USER'S GUIDE

Appendix A. Schematic and Layouts

A.1 INTRODUCTION

This appendix contains the following schematics and layouts for the MCP3425 SOT23-6 Evaluation Board:

- Board – Schematic
- Board – Top Layer
- Board – Top Metal Layer
- Board – Bottom Layer

A.3 BOARD – TOP LAYER

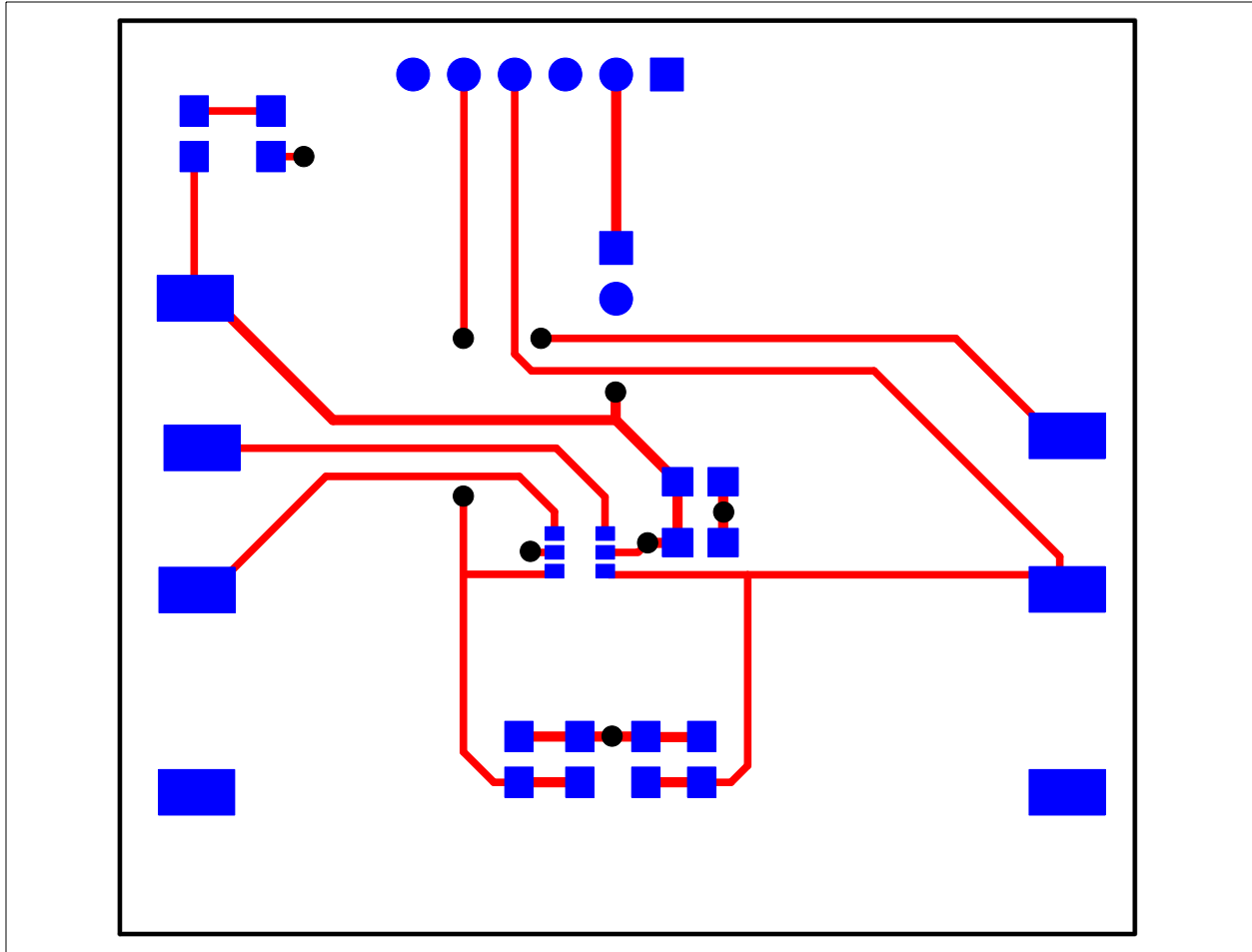

MCP3425 SOT23-6 Evaluation Board User's Guide

A.4 BOARD – TOP METAL LAYER

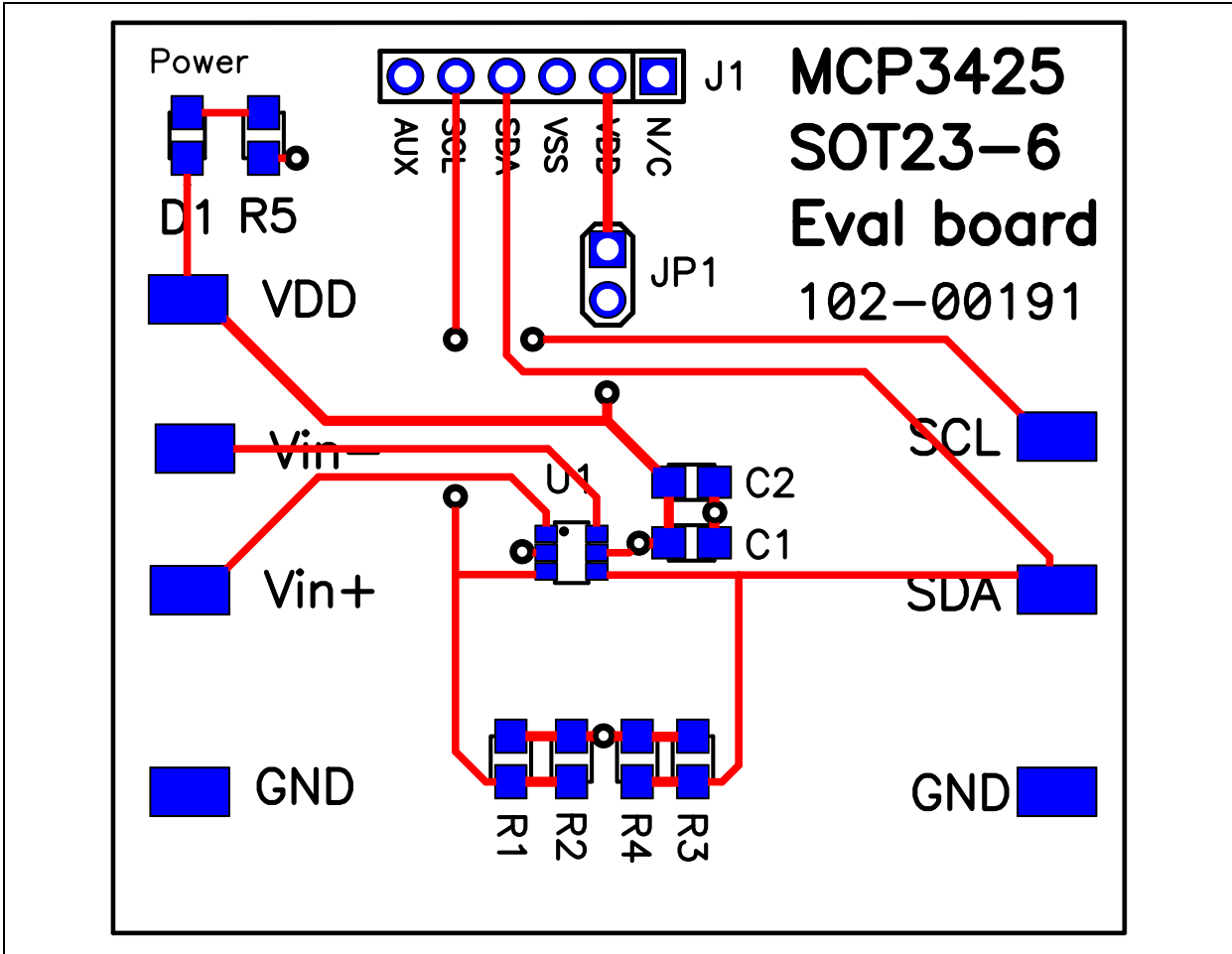

A.5 BOARD – BOTTOM LAYER

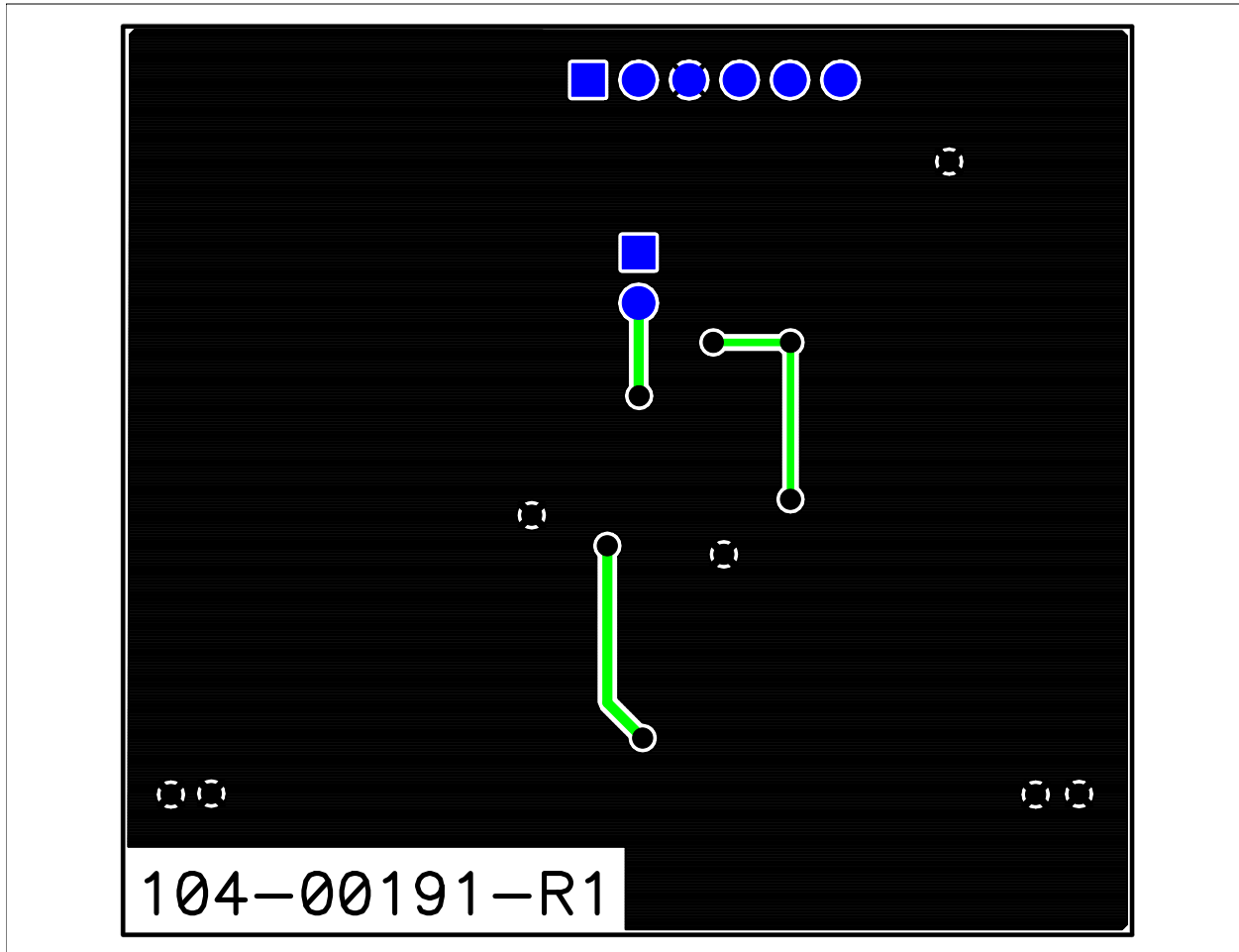

MCP3425 SOT23-6 Evaluation Board User's Guide

NOTES:

Appendix B. Bill Of Materials (BOM)

TABLE B-1: BILL OF MATERIALS

Qty	Reference	Description	Manufacturer	Part Number
1	C1	CAP .1UF 25V CERAMIC X7R 0805	Panasonic® - ECG	ECJ-2VB1E104K
1	C2	CAP CERAMIC 10UF 6.3V X5R 0805	Panasonic - ECG	ECJ-2FB0J106K
1	D1	LED RED ORANGE CLEAR 0805 SMD	LITE-ON INC	LTST-C170EKT
1	J1	CONN HEADER 6POS .100 R/A GOLD	Molex/Waldom Electronics Corp	22-28-8062
1	PCB	RoHS Compliant Bare PCB, MCP3425 SOT23-6 Eval Board	—	104-00191
2	R1, R3	RES 4.99K OHM 1/8W 1% 0805 SMD	Panasonic - ECG	ERJ-6ENF4991V
	R2, R4	DO NOT POPULATE	—	—
1	R5	RES 470 OHM 1/8W 5% 0805 SMD	Panasonic - ECG	ERJ-6GEYJ471V
1	U1	16-Bit Analog-to-Digital Converter with I2C Interface and On-Board Reference	Microchip Technology Inc.	MCP3425A0T-E/CH
7	VDD V _{IN+} V _{IN-} GND SCL SDA VDD	TEST POINT PC COMPACT SMT	Keystone Electronics®	5016

Note: The components listed in this Bill of Materials are representative of the PCB assembly. The released BOM used in manufacturing uses all RoHS-compliant components.



WORLDWIDE SALES AND SERVICE

AMERICAS

Corporate Office
2355 West Chandler Blvd.
Chandler, AZ 85224-6199
Tel: 480-792-7200
Fax: 480-792-7277
Technical Support:
<http://support.microchip.com>
Web Address:
www.microchip.com

Atlanta
Duluth, GA
Tel: 678-957-9614
Fax: 678-957-1455

Boston
Westborough, MA
Tel: 774-760-0087
Fax: 774-760-0088

Chicago
Itasca, IL
Tel: 630-285-0071
Fax: 630-285-0075

Dallas
Addison, TX
Tel: 972-818-7423
Fax: 972-818-2924

Detroit
Farmington Hills, MI
Tel: 248-538-2250
Fax: 248-538-2260

Kokomo
Kokomo, IN
Tel: 765-864-8360
Fax: 765-864-8387

Los Angeles
Mission Viejo, CA
Tel: 949-462-9523
Fax: 949-462-9608

Santa Clara
Santa Clara, CA
Tel: 408-961-6444
Fax: 408-961-6445

Toronto
Mississauga, Ontario,
Canada
Tel: 905-673-0699
Fax: 905-673-6509

ASIA/PACIFIC

Asia Pacific Office
Suites 3707-14, 37th Floor
Tower 6, The Gateway
Harbour City, Kowloon
Hong Kong
Tel: 852-2401-1200
Fax: 852-2401-3431

Australia - Sydney
Tel: 61-2-9868-6733
Fax: 61-2-9868-6755

China - Beijing
Tel: 86-10-8528-2100
Fax: 86-10-8528-2104

China - Chengdu
Tel: 86-28-8665-5511
Fax: 86-28-8665-7889

China - Hong Kong SAR
Tel: 852-2401-1200
Fax: 852-2401-3431

China - Nanjing
Tel: 86-25-8473-2460
Fax: 86-25-8473-2470

China - Qingdao
Tel: 86-532-8502-7355
Fax: 86-532-8502-7205

China - Shanghai
Tel: 86-21-5407-5533
Fax: 86-21-5407-5066

China - Shenyang
Tel: 86-24-2334-2829
Fax: 86-24-2334-2393

China - Shenzhen
Tel: 86-755-8203-2660
Fax: 86-755-8203-1760

China - Wuhan
Tel: 86-27-5980-5300
Fax: 86-27-5980-5118

China - Xiamen
Tel: 86-592-2388138
Fax: 86-592-2388130

China - Xian
Tel: 86-29-8833-7252
Fax: 86-29-8833-7256

China - Zhuhai
Tel: 86-756-3210040
Fax: 86-756-3210049

ASIA/PACIFIC

India - Bangalore
Tel: 91-80-4182-8400
Fax: 91-80-4182-8422

India - New Delhi
Tel: 91-11-4160-8631
Fax: 91-11-4160-8632

India - Pune
Tel: 91-20-2566-1512
Fax: 91-20-2566-1513

Japan - Yokohama
Tel: 81-45-471- 6166
Fax: 81-45-471-6122

Korea - Daegu
Tel: 82-53-744-4301
Fax: 82-53-744-4302

Korea - Seoul
Tel: 82-2-554-7200
Fax: 82-2-558-5932 or
82-2-558-5934

Malaysia - Kuala Lumpur
Tel: 60-3-6201-9857
Fax: 60-3-6201-9859

Malaysia - Penang
Tel: 60-4-227-8870
Fax: 60-4-227-4068

Philippines - Manila
Tel: 63-2-634-9065
Fax: 63-2-634-9069

Singapore
Tel: 65-6334-8870
Fax: 65-6334-8850

Taiwan - Hsin Chu
Tel: 886-3-572-9526
Fax: 886-3-572-6459

Taiwan - Kaohsiung
Tel: 886-7-536-4818
Fax: 886-7-536-4803

Taiwan - Taipei
Tel: 886-2-2500-6610
Fax: 886-2-2508-0102

Thailand - Bangkok
Tel: 66-2-694-1351
Fax: 66-2-694-1350

EUROPE

Austria - Wels
Tel: 43-7242-2244-39
Fax: 43-7242-2244-393

Denmark - Copenhagen
Tel: 45-4450-2828
Fax: 45-4485-2829

France - Paris
Tel: 33-1-69-53-63-20
Fax: 33-1-69-30-90-79

Germany - Munich
Tel: 49-89-627-144-0
Fax: 49-89-627-144-44

Italy - Milan
Tel: 39-0331-742611
Fax: 39-0331-466781

Netherlands - Drunen
Tel: 31-416-690399
Fax: 31-416-690340

Spain - Madrid
Tel: 34-91-708-08-90
Fax: 34-91-708-08-91

UK - Wokingham
Tel: 44-118-921-5869
Fax: 44-118-921-5820