

DETAILS

Product Number	CA13362_STRADA-SQ-VSM
Family	Strada-SQ
Type	Assembly
Color	clear
Diameter	25 mm
Height	6.9 mm
Style	square
Optic Material	PMMA
Holder Material	
Fastening	screw, tape
Status	ready
ROHS Compliant	Yes
Date Updated	26/08/2014



OPTICAL PROPERTIES

LED	Viewing	Light	Effi-	cd/lm	Connector
	Angle	Beam	ciency		
LUXEON H50-2	sim: 140	Wide-Area...	sim: 90 %	sim: 0.550	-
LUXEON T	145 deg	Wide-Area...	92 %	0.700	-
LUXEON TX	148 deg	Wide-Area...	94 %	0.670	-
LUXEON MZ	149 deg	Wide-Area...	94 %	0.410	-
XT-E	151 deg	Wide-Area...	93 %	0.200	-
XM-L	154 deg	Wide-Area...	93 %	0.200	-
LUXEON M	154 deg	Wide-Area...	93 %	0.250	-
MK-R	156 deg	Wide-Area...	91 %	0.300	-

D

C

B

A

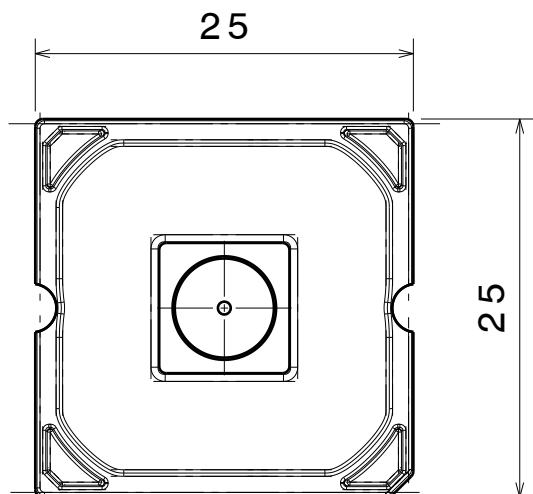

Bottom view

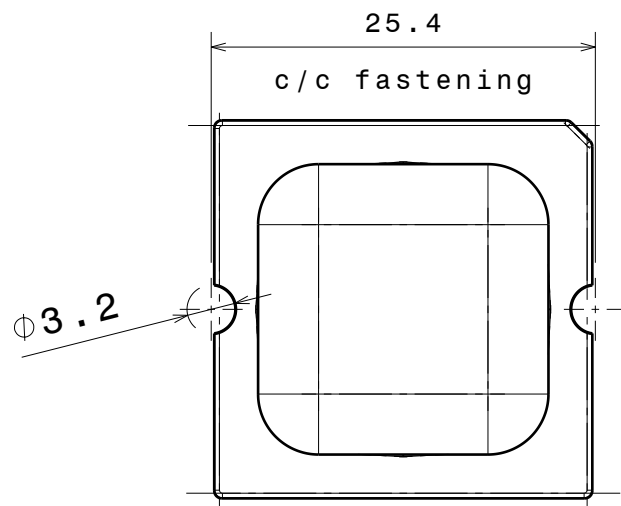

Top view

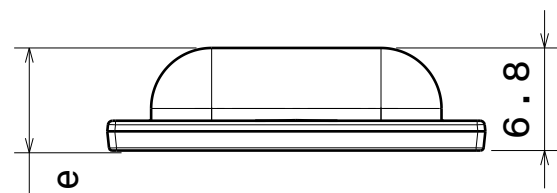

Front view

6.9
with tape

Tolerances if not otherwise shown
 According to DIN ISO 2768-1
 Linear measures:
 Up to 30mm class M, otherwise class C.
 According to DIN ISO 2768-2
 Form and position: class L

LEDiL Ledil Oy
 Salorankatu 10
 FIN 24240 SALO
 Finland

THIRD ANGLE PROJECTION:

DRAWING TITLE
STRADA-SQ-VSM MechanicalDrawing

This drawing is the property of LEDiL Oy. It may not be reproduced, copied or communicated without a written agreement with LEDiL Oy."

SIZE	PART NUMBER
A4	-

SCALE	2:1	WEIGHT	-	SHEET	1/1
-------	-----	--------	---	-------	-----

D

A

Luminaire: LEDiL Oy CA12891_STRADA-SQ-VSM_(LUXEON_T) Eff.92.4%
Lamps: 1 x LUXEON T (74lm@250mA)

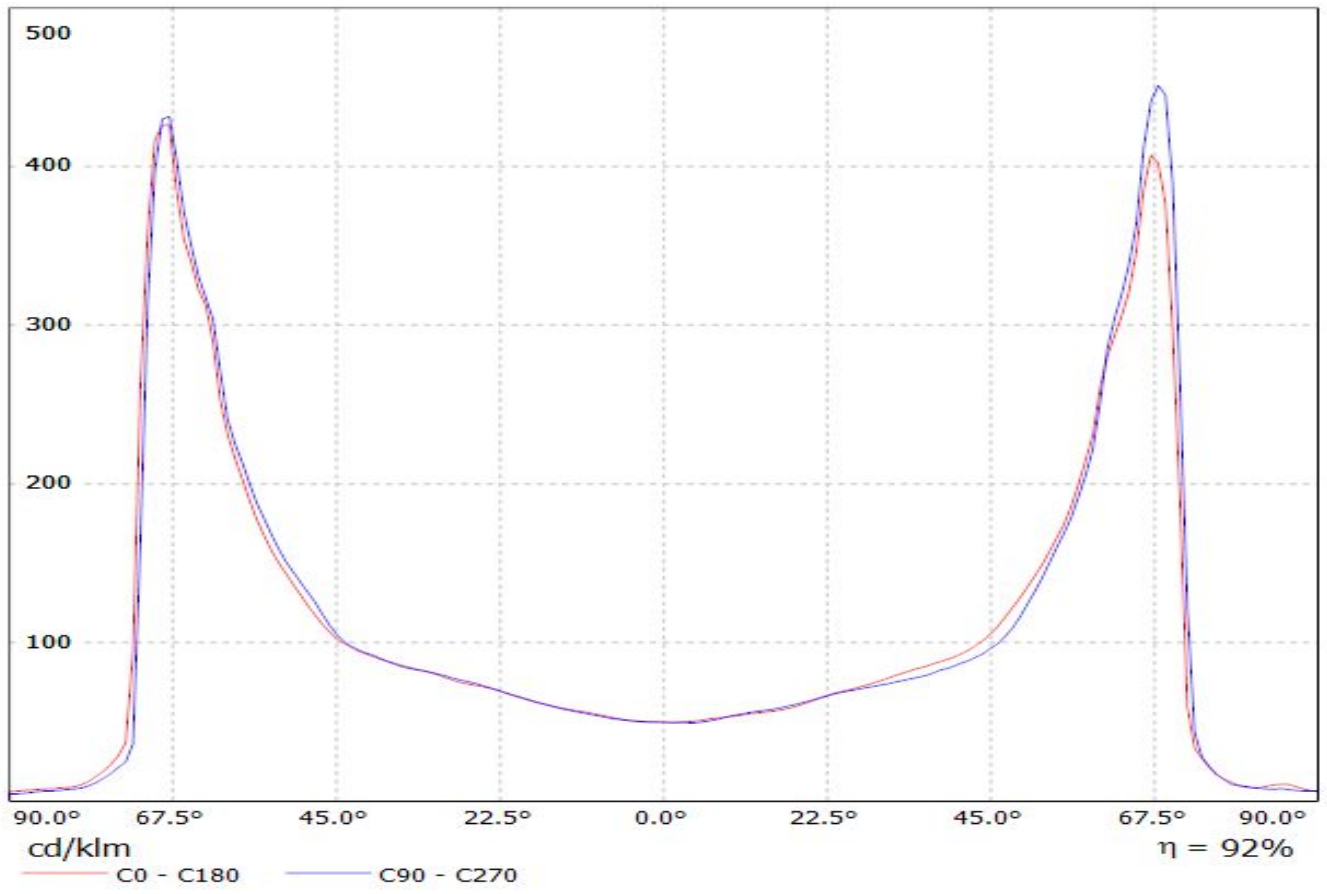

Luminaire: LEDiL Oy CA13362_STRADA-SQ-VSM_(Luxeon_TX) Eff.93.6%
Lamps: 1 x Luxeon_TX_(L1T2-3585)_80.1801lm@250mA_CCT=3500K_P=0.731482W_I=249.9mA

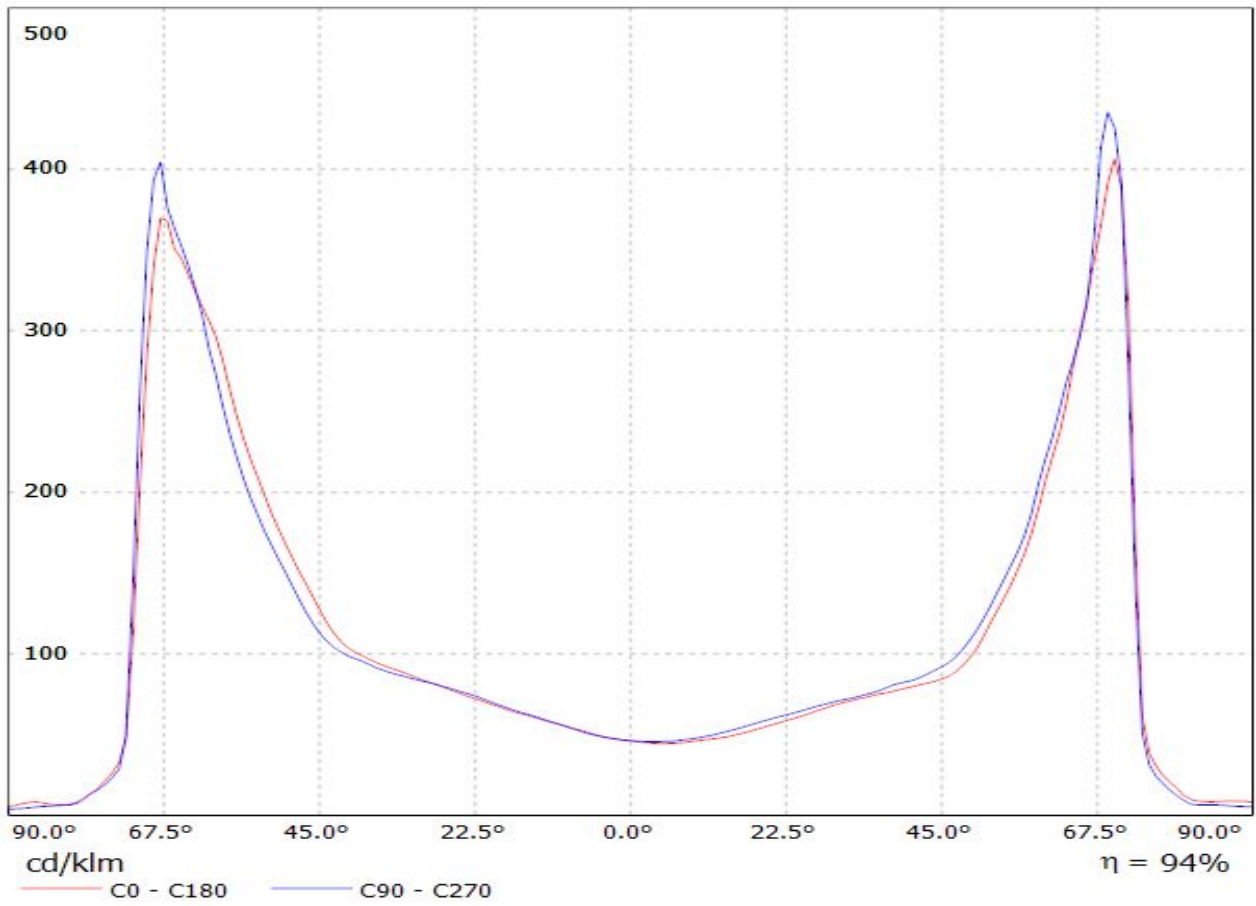

Luminaire: LEDil Oy CA13362_STRADA-SQ-VSM_(Luxeon_MZ) Efficiency=94%
Lamps: 1 x Philips Lumileds Luxeon MZ (387lm @ 250mA) CCT=3800K P=2.8W I=250mA

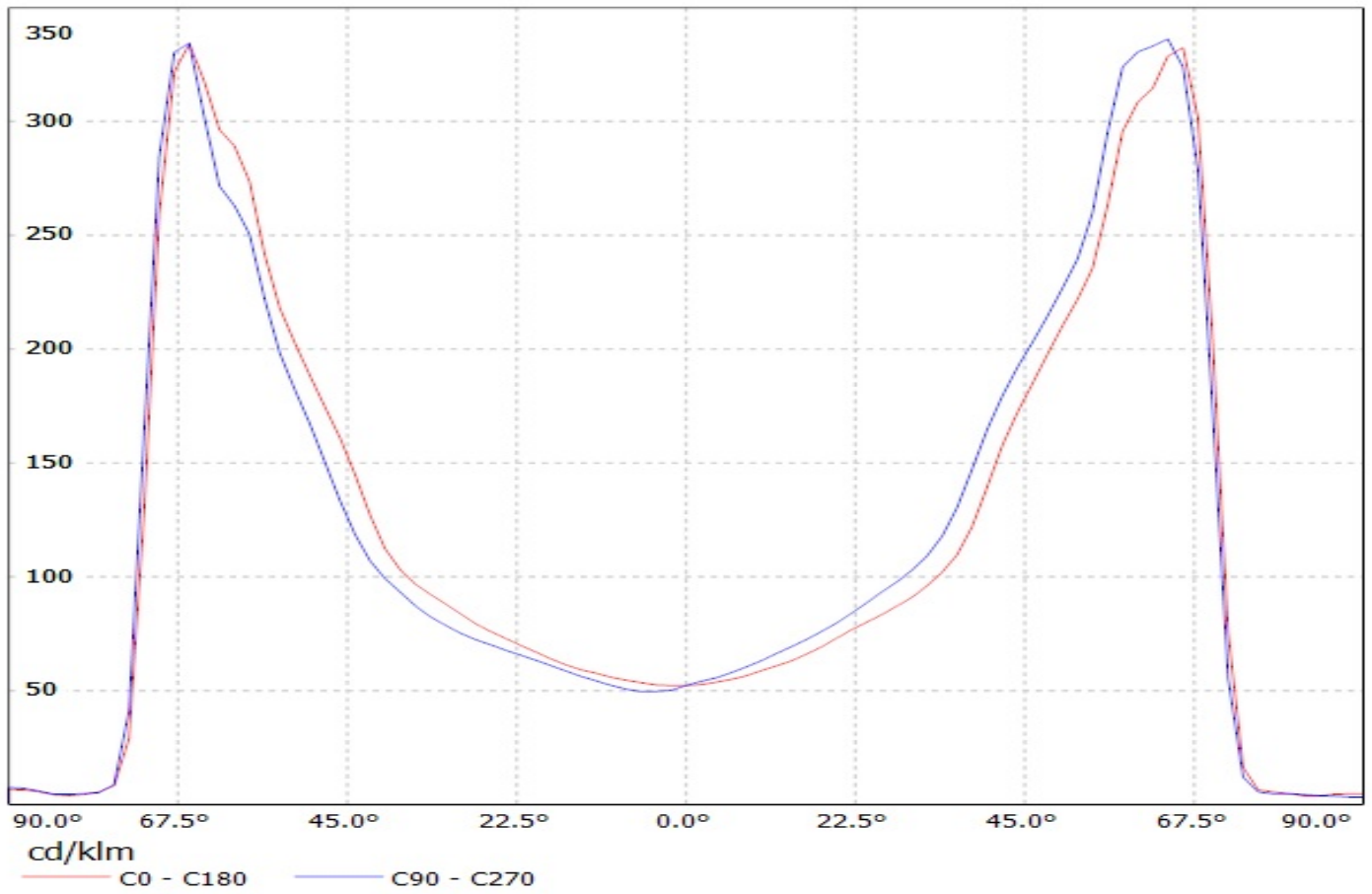

Luminaire: LEDiL Oy CA12891_STRADA-SQ-VSM_(XT-E) Eff. 93%
Lamps: 1 x Cree XT-E 100lm @ 250mA

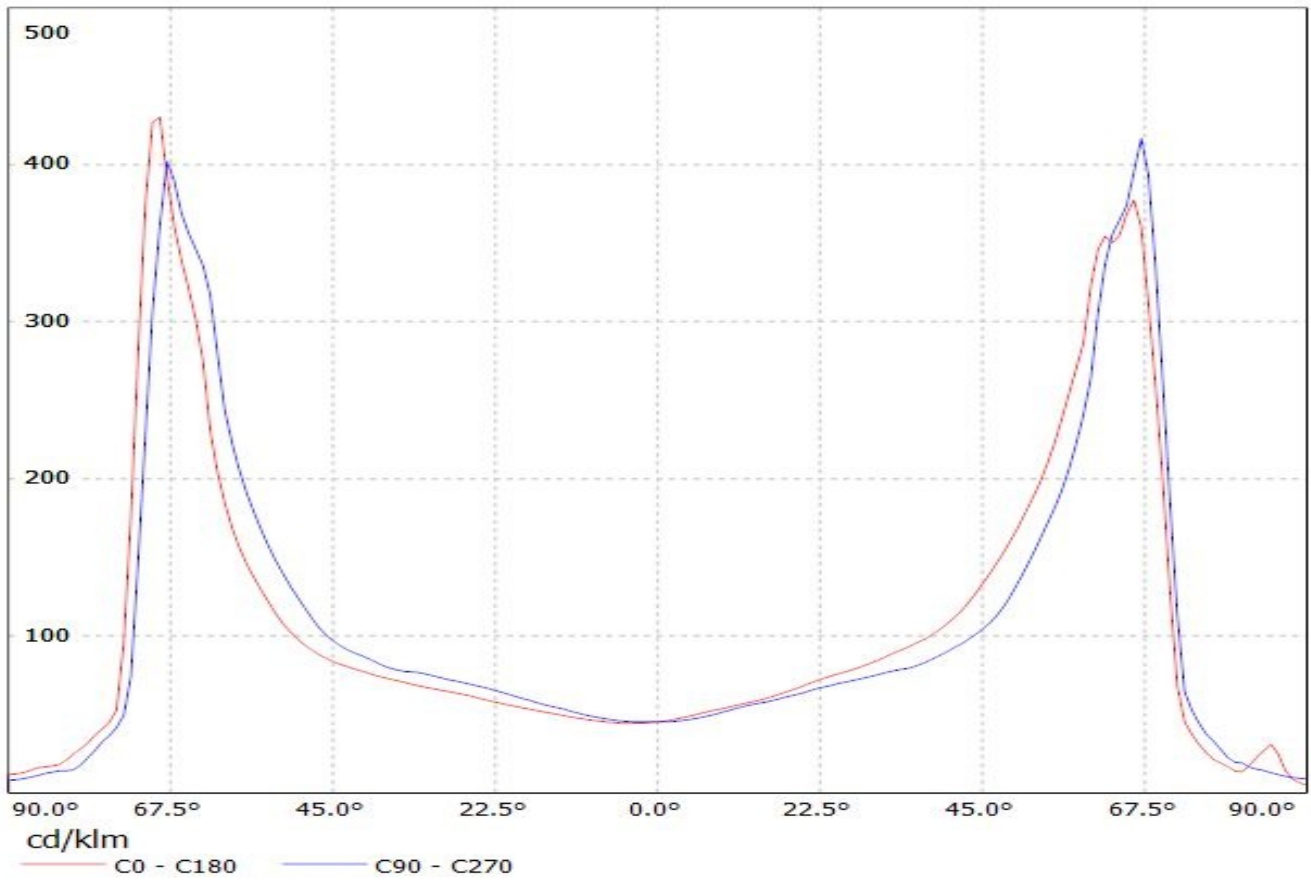

Luminaire: LEDiL Oy CA12891_STRADA-SQ-VSM_(XM-L) Eff.93%
Lamps: 1 x CREE_XM-L_78.0576lm@250mA_P=0.71104W_I=249.9mA

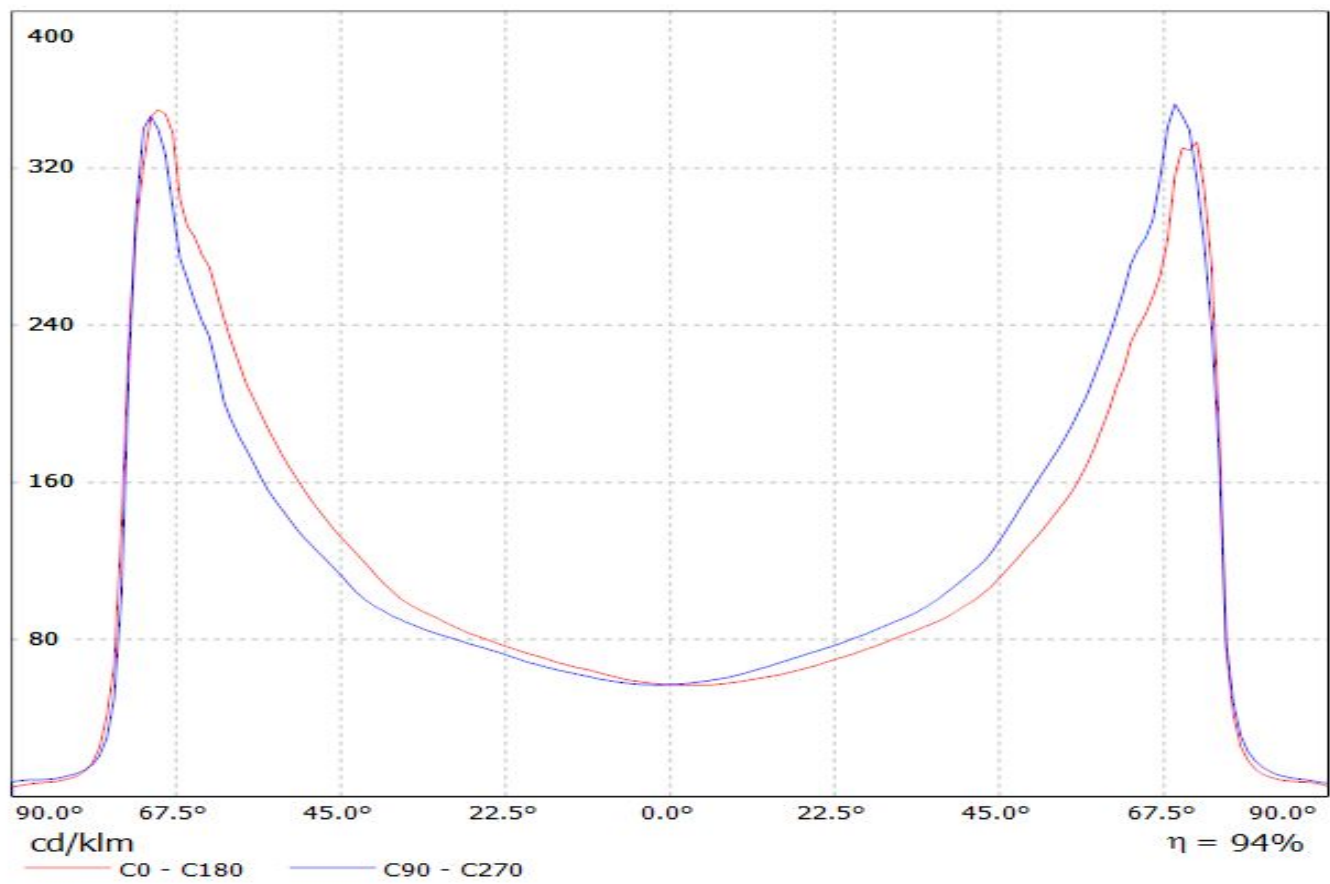

Luminaire: LEDIL OY C12727_STRADA-SQ-VSM (Luxeon M) Efficiency=95%
Lamps: 1 x Luxeon M (360lm@250mA)

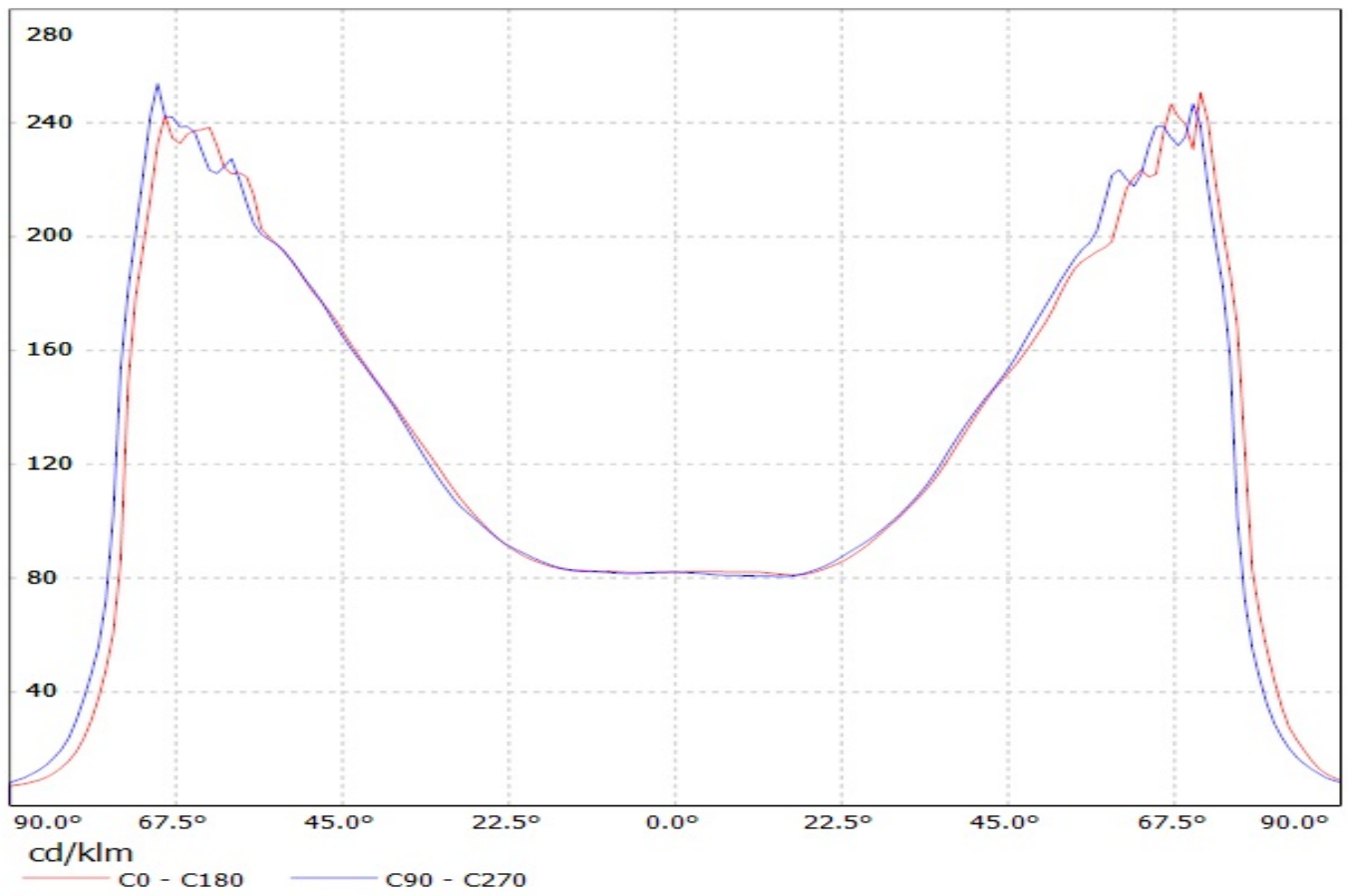

LEDiL Oy CA12891_STRADA-SQ-VSM_(MKR) Eff.90.8% / LDC (Linear)

Luminaire: LEDiL Oy CA12891_STRADA-SQ-VSM_(MKR) Eff.90.8%

Lamps: 1 x Cree MKR (368.505lm@250mA)

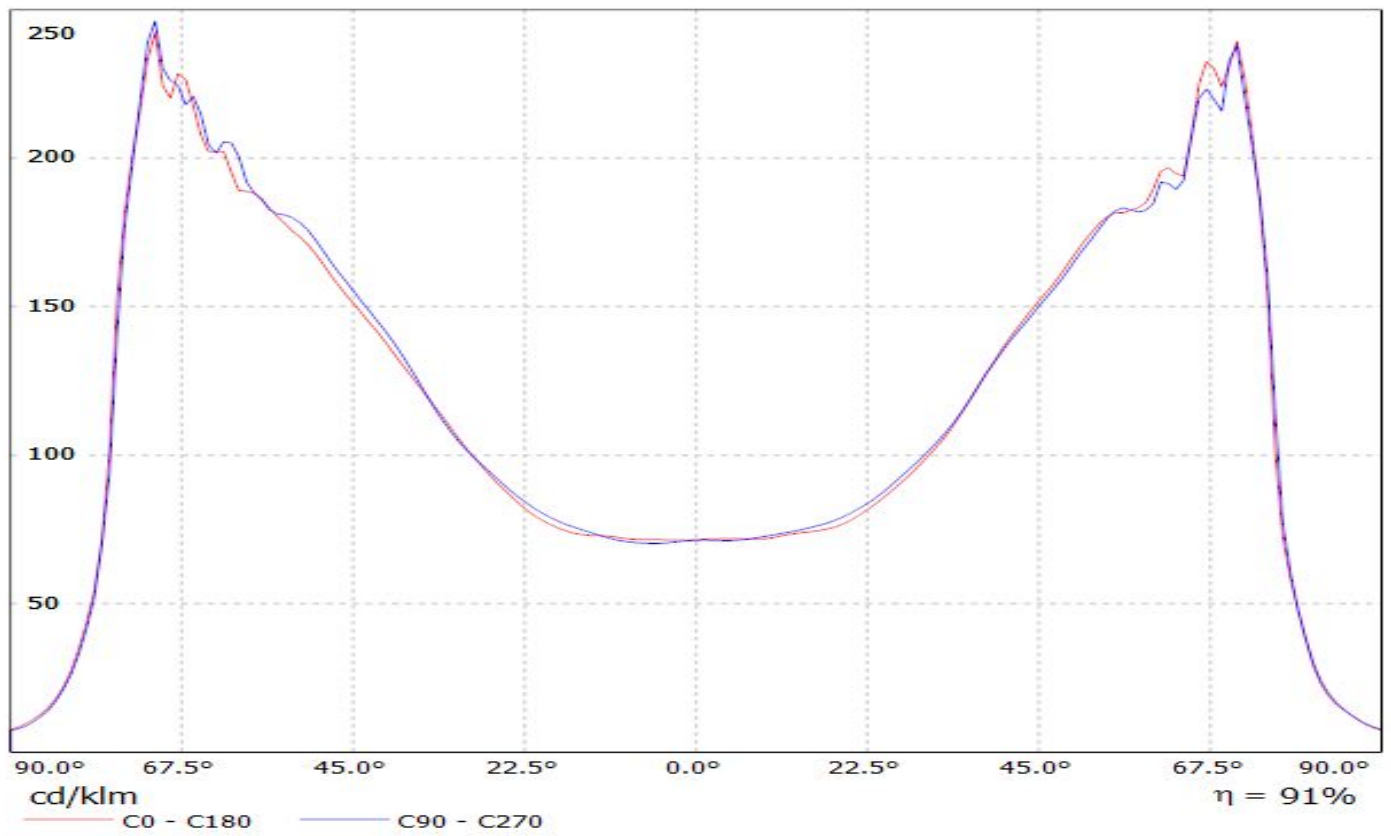

Luminaire: LEDiL Oy CA12891_STRADA-SQ-VSM_(LUXEON_T) Eff.92.4%
Lamps: 1 x LUXEON T (74lm@250mA)

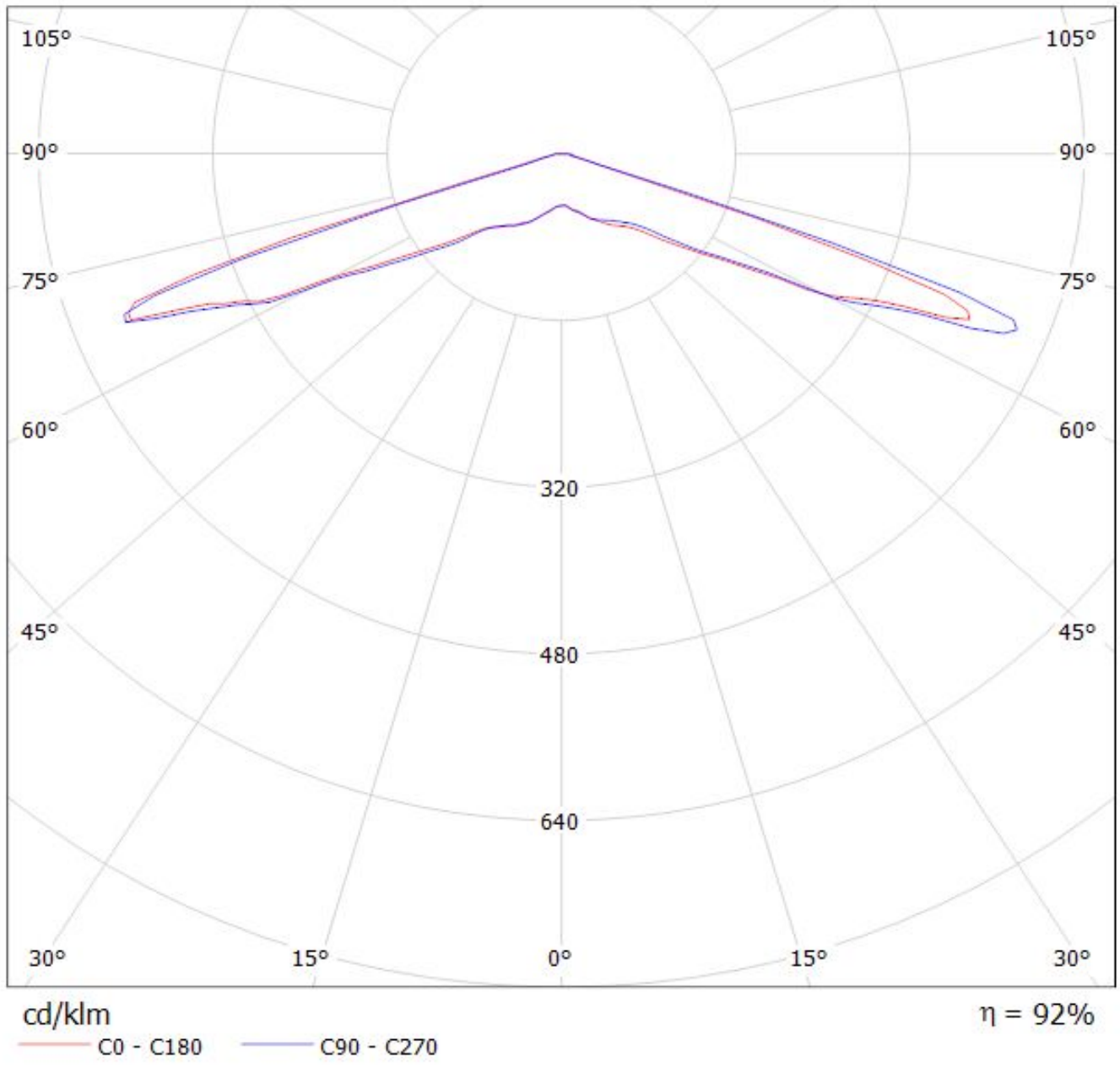

Luminaire: LEDiL Oy CA13362_STRADA-SQ-VSM_(Luxeon_TX) Eff.93.6%
Lamps: 1 x Luxeon_TX_(L1T2-3585)_80.1801lm@250mA_CCT=3500K_P=0.731482W_I=249.9mA

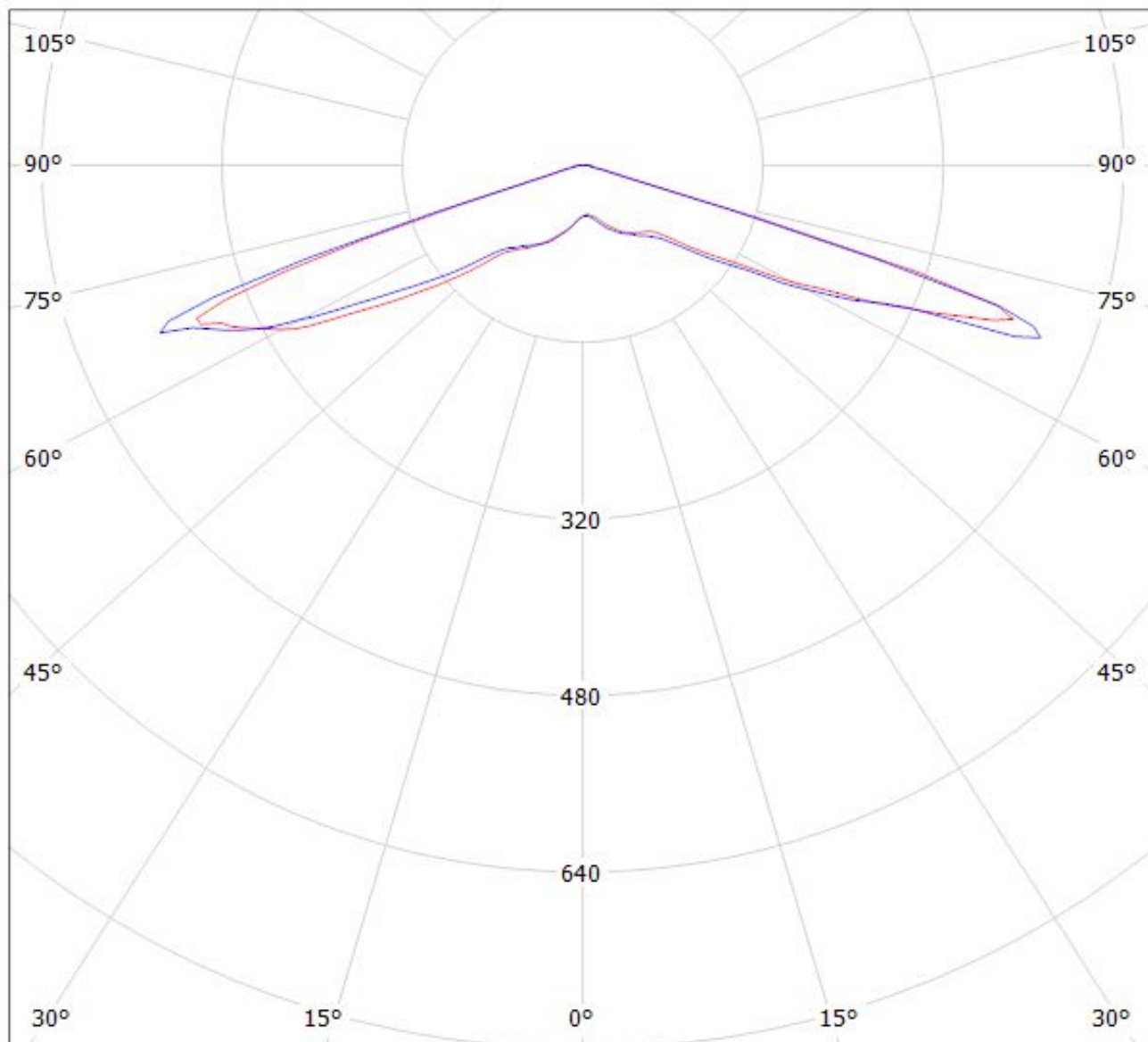

cd/klm

$\eta = 94\%$

— C0 - C180 — C90 - C270

Luminaire: LEDil Oy CA13362_STRADA-SQ-VSM_(Luxeon_MZ) Efficiency=94%
Lamps: 1 x Philips Lumileds Luxeon MZ (387lm @ 250mA) CCT=3800K P=2.8W I=250mA

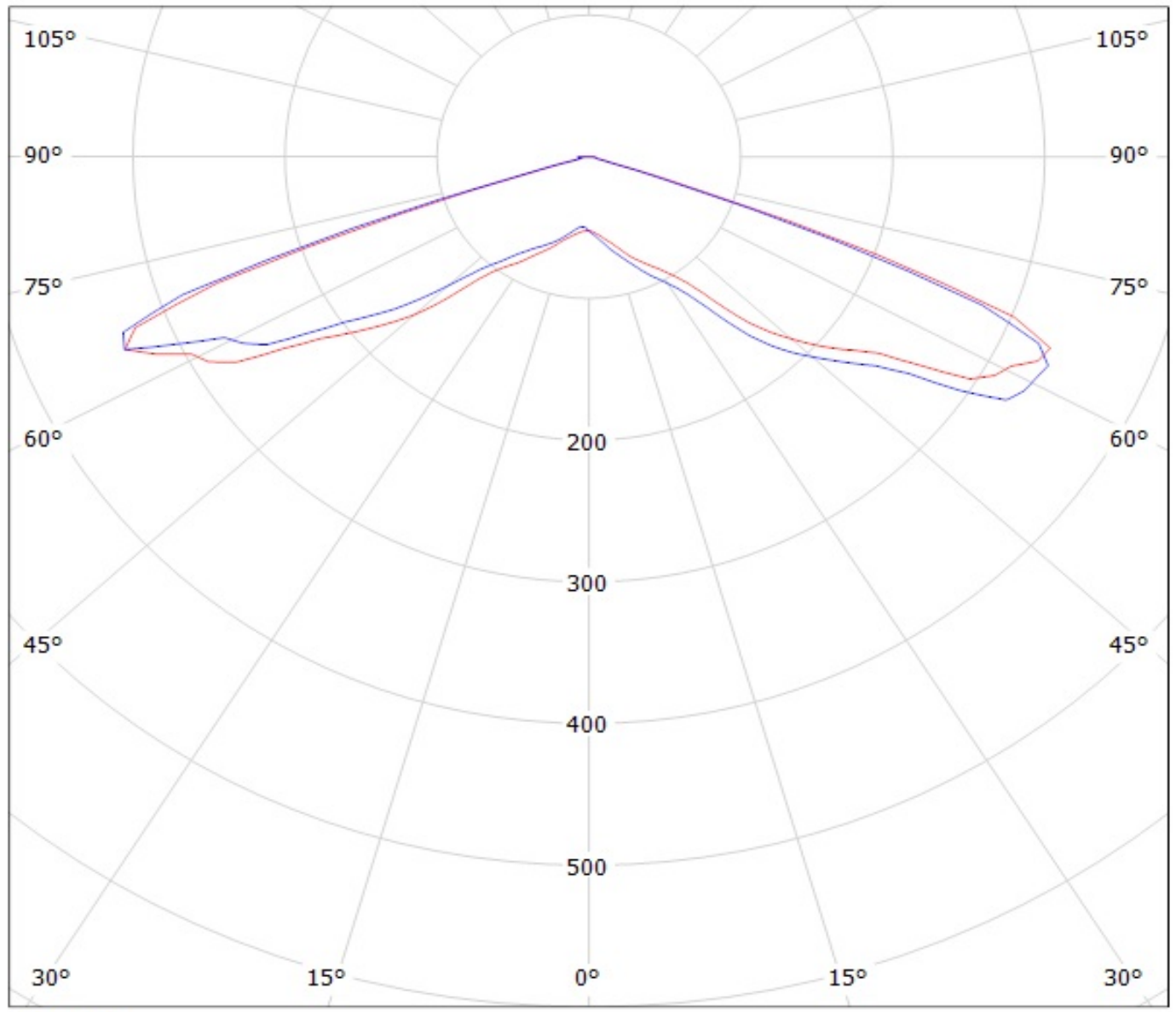

cd/klm

— C0 - C180 — C90 - C270

Luminaire: LEDiL Oy CA12891_STRADA-SQ-VSM_(XT-E) Eff. 93%
Lamps: 1 x Cree XT-E 100lm @ 250mA

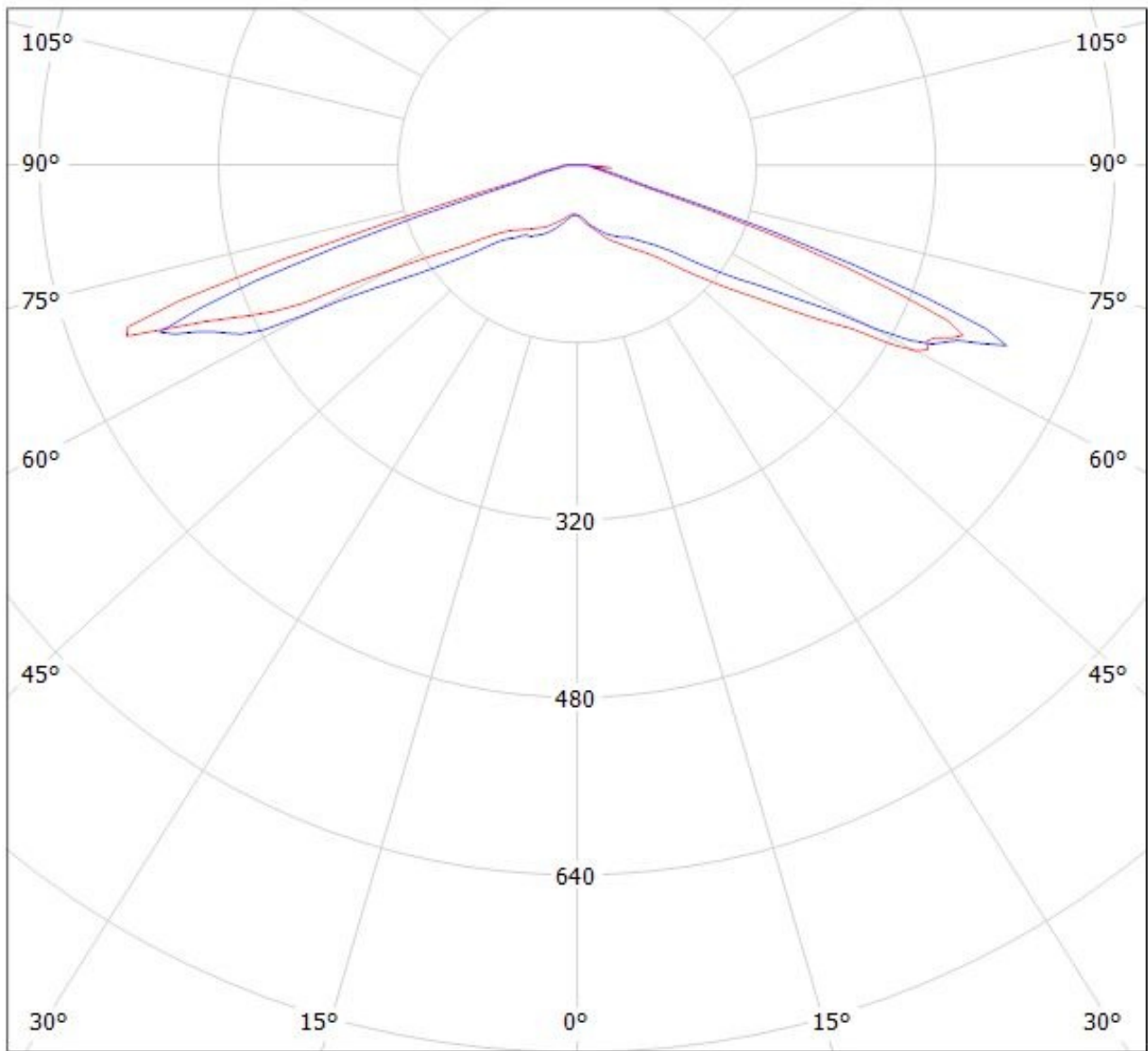

cd/klm

— C0 - C180 — C90 - C270

Luminaire: LEDiL Oy CA12891_STRADA-SQ-VSM_(XM-L) Eff.93%
Lamps: 1 x CREE_XM-L_78.0576lm@250mA_P=0.71104W_I=249.9mA

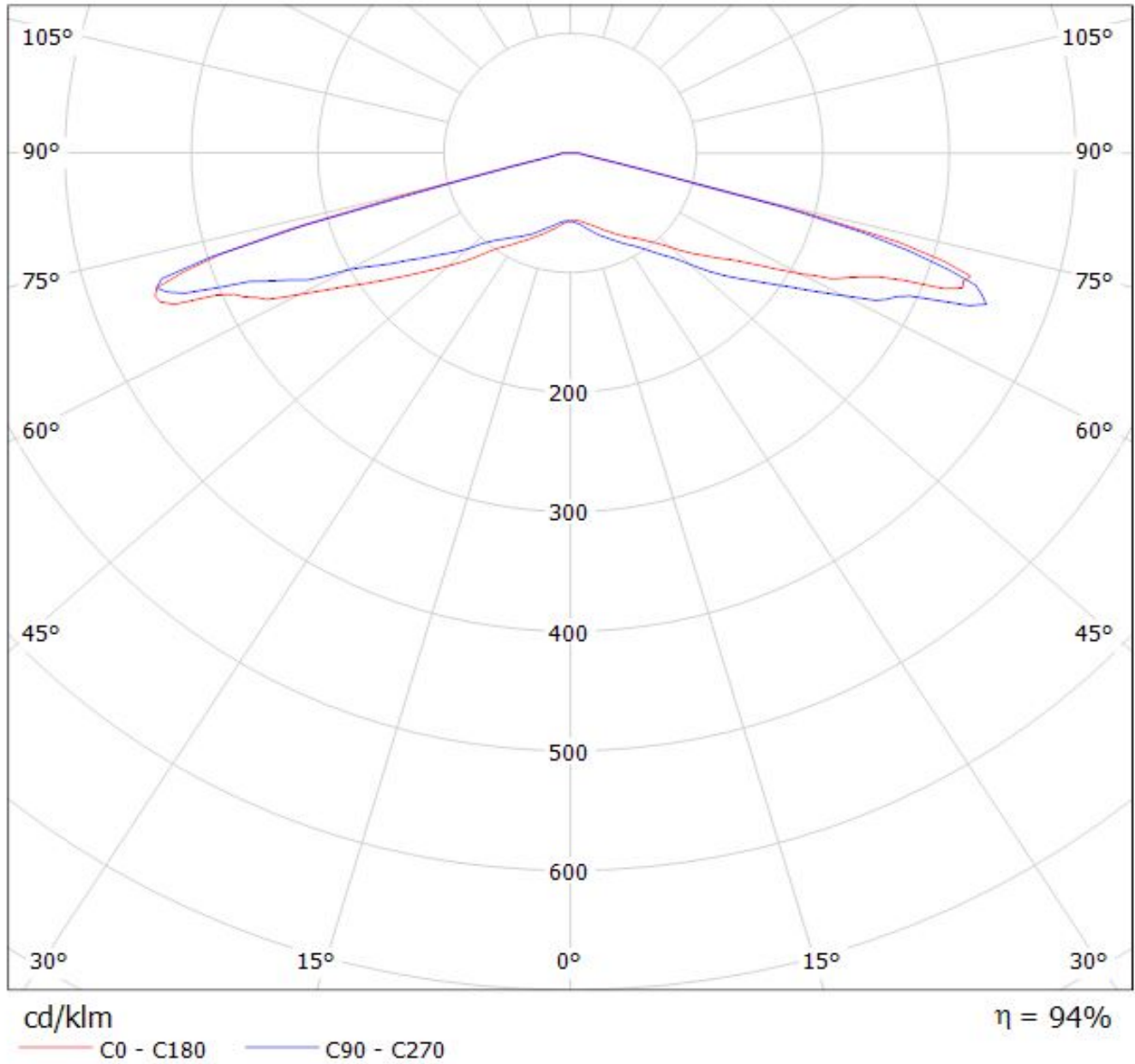

Luminaire: LEDIL OY C12727_STRADA-SQ-VSM (Luxeon M) Efficiency=95%
Lamps: 1 x Luxeon M (360lm@250mA)

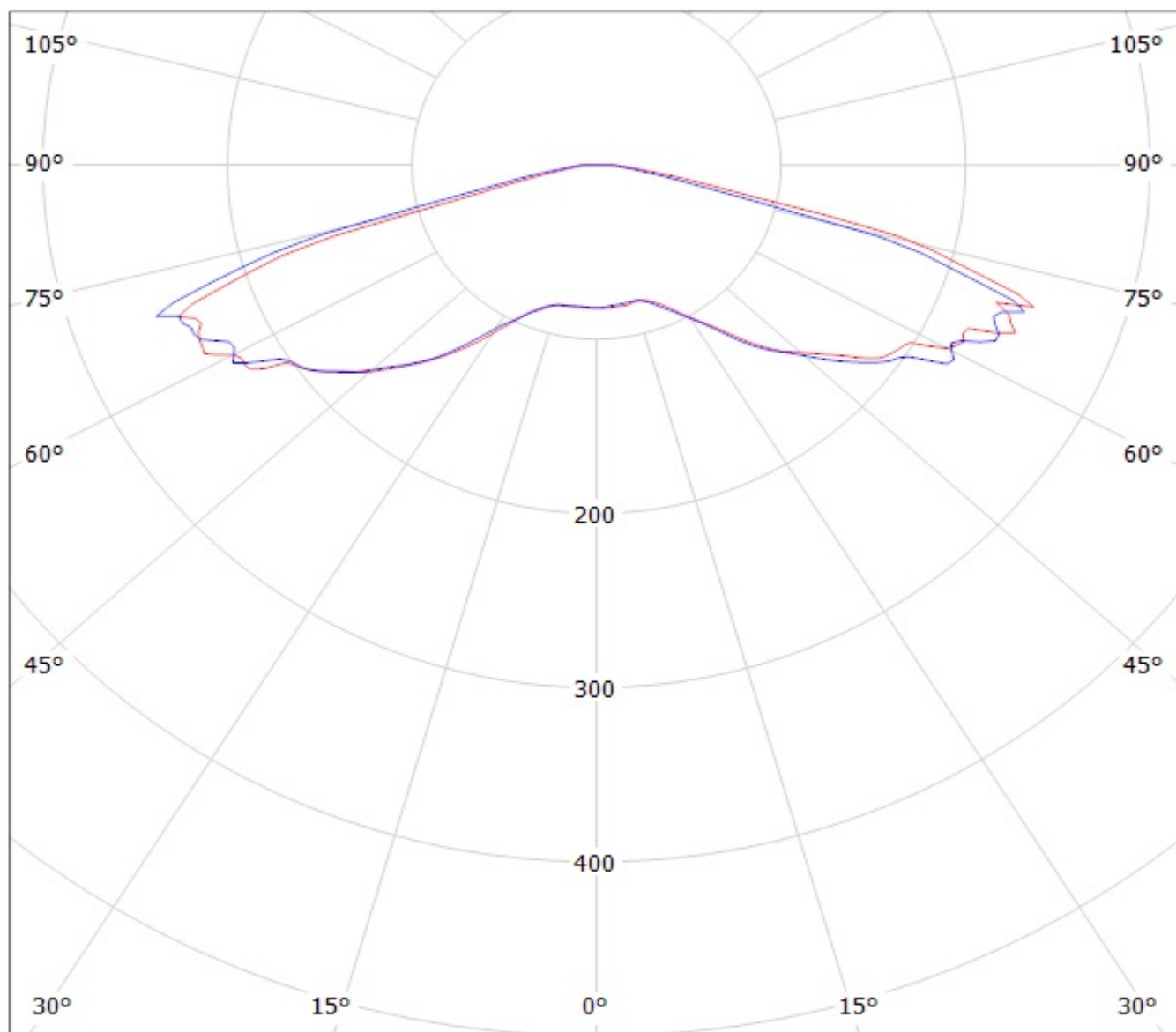

cd/klm

— C0 - C180

— C90 - C270

LEDiL Oy CA12891_STRADA-SQ-VSM_(MKR) Eff.90.8% / LDC (Polar)

Luminaire: LEDiL Oy CA12891_STRADA-SQ-VSM_(MKR) Eff.90.8%

Lamps: 1 x Cree MKR (368.505lm@250mA)

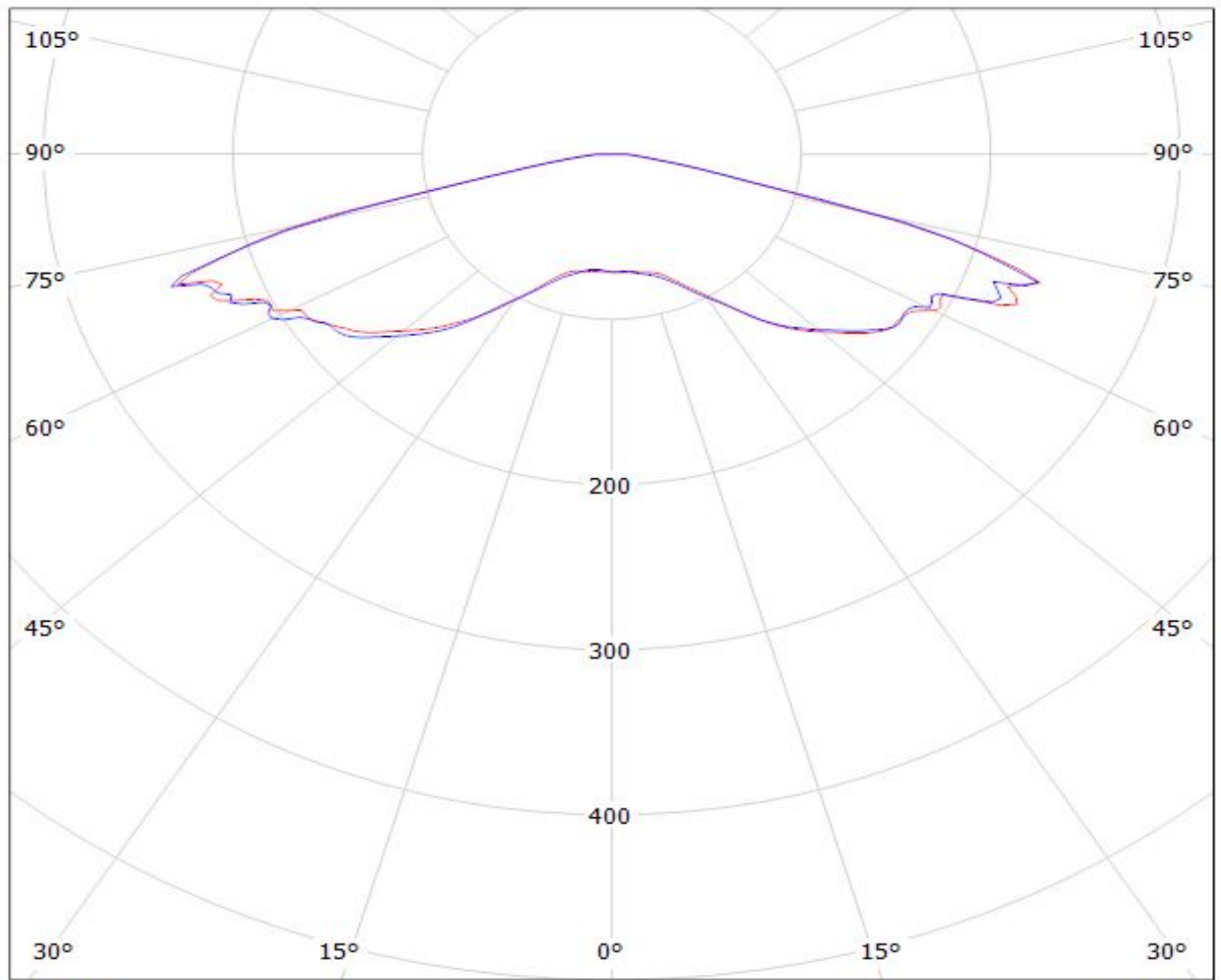

cd/klm

$\eta = 91\%$

— C0 - C180 — C90 - C270

NOTE: The typical divergence will be changed by different color, chip size and chip position tolerance. The typical total divergence is the full angle measured where the luminous intensity is half of the peak value.