

**What is a TCXO ?**

By the integration of a resistor / capacitor compensation network and a sensor circuitry, the frequency stability of a crystal oscillator (XO) can be improved by about 100 times. The resultant reactance change from the compensation network offsets the frequency-temperature (F-T) characteristics of the crystal. The F-T characteristics is unique to individual crystal, therefore each unit is individually temperature compensated in the TCXO manufacturing.

At Mercury, our computerized temperature cycling chambers, data acquisition system and unique network calculation software allow us to produce low cost and high quality TCXOs. Most importantly, it is **Mercury** crystal inside.

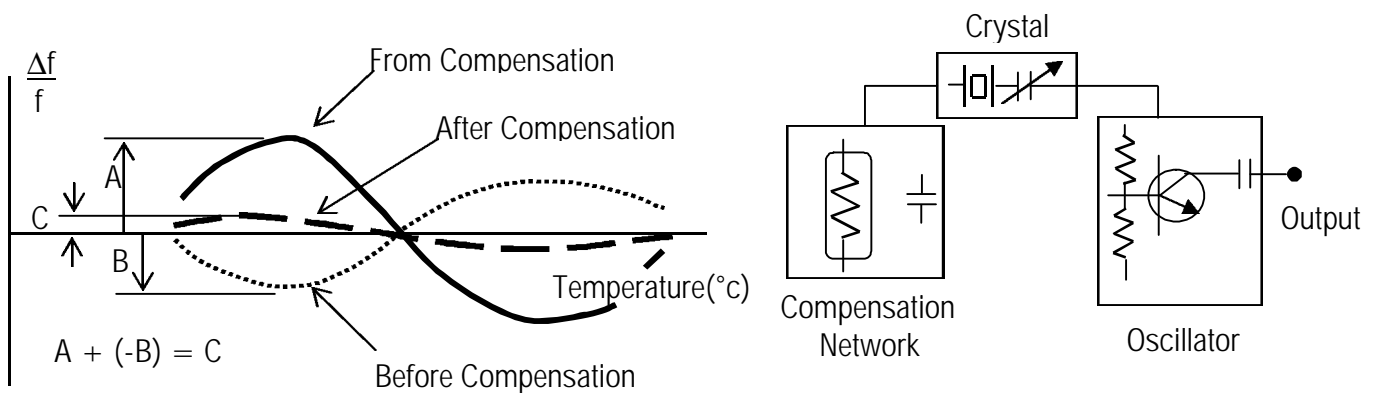

**Product Features:**

- ◆ Variety of packages to choose from including hermetically sealed, non-hermetically sealed, thru-hole and SMD
- ◆ **Electronic** frequency tuning (for VCTCXO): The output frequency can be tuned up or down electronically by the control voltage applied on the voltage control pin.
- ◆ **Mechanical** frequency tuning (for TCXO and VCTCXO): Trimmer (variable capacitor) is used to adjust the output frequency mechanically.
- ◆ Unique crystal design to achieve lowest possible phase noise, aging and frequency perpetration
- ◆ **Quick-turn** service available: 1 ~ 4 weeks for selected packages. Custom or standard frequencies.
- ◆ Applications include mobile phones, PHS, GPS, instrumentation and broadband access.

**MERCURY [www.mercury-crystal.com](http://www.mercury-crystal.com)**

Taiwan: TEL (886)-2-2406-2779, FAX (886)-2-2496-0769, e-mail: [sales-tw@mercury-crystal.com](mailto:sales-tw@mercury-crystal.com)

U.S.A.: TEL (1)-909-466-0427, FAX (1)-909-466-0762, e-mail: [sales-us@mercury-crystal.com](mailto:sales-us@mercury-crystal.com)

**"TCXO" and "VCTCXO"**  
**Wave Form: Clipped Sine Wave**



**MERCURY**  
 Since 1973

**Product Summary:**

**CLIPPED SINE**

Output Wave Form: Clipped Sine Wave					
TCXO	VCTCXO	Available Frequency Range	Package size (mm), L x W x seated height		Package size (inches), L x W x seated height
<b>Thru-Hole Types</b>					
M38S	VM38S	9.6 ~ 26 MHz	4 pin DIP	11.7 x 18.4 x 7.3	[0.460 x 0.724 x 0.287]
M39S	VM39S	9.6 ~ 26 MHz	4 pin DIP	11.7 x 18.3 x 4.7	[0.460 x 0.724 x 0.185]
M14S	VM14S	9.6 ~ 26 MHz	4 pin DIP. Hermetically sealed.	12.8 x 20.2 x 8.3	[0.504 x 0.795 x 0.327]
M15S	VM15S	9.6 ~ 26 MHz	4 pin DIP. With trimmer	12.8 x 20.2 x 8.3	[0.504 x 0.795 x 0.327]
M8S	VM8S	10.0 ~ 26 MHz	4 pin DIP. Half size. Hermetically sealed. No trimmer	12.8 x 12.8 x 8.3	[0.504 x 0.504 x 0.327]
M19S	VM19S	9.6 ~ 26 MHz	5 pin DIP	19.8 x 19.8 x 10.0	[0.780 x 0.780 x 0.394]
M48S	VM48S	1.0 ~ 80 MHz	4 pin DIP	24.1 x 24.1 x 7.5	[0.949 x 0.949 x 0.295]
M58S	VM58S	1.0 ~ 80 MHz	5 pin DIP	24.1 x 24.1 x 7.5	[0.949 x 0.949 x 0.295]
M78S	VM78S	1.0 ~ 80 MHz	4 pin DIP	24.1 x 24.1 x 7.5	[0.949 x 0.949 x 0.295]
<b>Gull Wing Surface Mount Types</b>					
M55S	VM55S	9.6 ~ 26 MHz	4 pin gull wing	11.7 x 21.3 x 6.6	[0.460 x 0.839 x 0.260]
M47S	VM47S	9.6 ~ 26 MHz	4 pin gull wing	11.7 x 21.3 x 4.7	[0.460 x 0.839 x 0.185]
M24S	VM24S	9.6 ~ 26 MHz	4 pin gull wing. Hermetically sealed.	12.8 x 20.2 x 9.3	[0.504 x 0.795 x 0.366]
M25S	VM25S	9.6 ~ 26 MHz	4 pin gull wing. With trimmer	12.8 x 20.2 x 9.3	[0.504 x 0.795 x 0.366]
M28S	VM28S	10.0 ~ 26 MHz	4 pin gull wing. Half size. Hermetically sealed. No trimmer.	12.8 x 12.8 x 9.3	[0.504 x 0.504 x 0.366]
<b>Leadless Surface Mount Types</b>					
M62S	VM62S	10.0 ~ 26 MHz	6 pad FR4 base. 2.5 mm H	9.6 x 11.4 x 2.5	[0.378 x 0.449 x 0.098]
M42S	VM42S	10.0 ~ 26 MHz	4 pad FR4 base. 2.5mm H	9.6 x 11.4 x 2.5	[0.378 x 0.449 x 0.098]
M64S	VM64S	9.6 ~ 26 MHz	6 pad FR4 base. 4.7 mm H	9.6 x 11.4 x 4.7	[0.378 x 0.449 x 0.185]
M44S	VM44S	9.6 ~ 26 MHz	4 pad FR4 base. 4.7 mm H	9.6 x 11.4 x 4.7	[0.378 x 0.449 x 0.185]
M57S	VM57S	10.0 ~ 26 MHz	4 pad ceramic base	5.0 x 7.5 x 1.9	[0.197 x 0.295 x 0.075]
M53S	VM53S	12.8 ~ 20 MHz	4 pad ceramic base	5.0 x 3.2 x 1.5	[0.197 x 0.126 x 0.059]

Note: Frequency tuning by the built-in mechanical trimmer (variable capacitor) is standard for all models except for models M8S, VM8S, M57S, VM57S, M53S and VM53S. Please specify when ordering if trimmer is not required.

Note: Because cleaning agent normally degrades the trimmer in the non-hermetically sealed packages, cleaning through washing cycles is not recommended. If cleaning is mandatory please choose hermetically sealed packages or no-trimmer option.

**"TCXO" and "VCTCXO"**  
**Wave Form: Clipped Sine Wave**



**MERCURY**  
 Since 1973

**General Specifications** (at +25°C and specified input voltage)

<b>Frequency Range</b>		9.6 MHz ~ 26.0 MHz	
<b>Output Wave Form</b>		Clipped Sine wave. Wave form code is "S"	
<b>Initial Calibration Tolerance</b>		Models with mechanical trimmer: Adjustable to the nominal frequency Models without mechanical trimmer: $\pm 3$ ppm at +25°C	
<b>Standard Frequencies (partial list)</b>		9.6, 10.0, 12.8, 13.0, 14.4, 15.36, 16.384, 19.2, 19.440, 19.68 MHz	
<b>Frequency Stability</b> vs Temperature vs Aging vs Voltage Change vs Load Change vs reflow (SMD models only)		$\pm 1$ ppm, $\pm 1.5$ ppm, $\pm 2.0$ ppm, $\pm 2.5$ ppm, $\pm 3$ ppm, $\pm 5$ ppm, over specified operating temperature range $\pm 1.0$ ppm max. first year at +25°C $\pm 0.3$ ppm max. for a $\pm 5\%$ input voltage change $\pm 0.3$ ppm max. for a $\pm 10\%$ loading condition change $\pm 1$ ppm max. 1 reflow and measured 24 hours afterwards	
<b>Typical Operating Temperature Range (examples)</b>		0°C to +60°C    0°C to +70°C    -10°C to +60°C -20°C to +70°C    -30°C to +60°C    -30°C to +75°C -40°C to +85°C (not available on all frequency stability listed above)	
<b>Mechanical Frequency Tuning</b>		$\pm 3$ ppm min. (from built-in trimming capacitor)	
<b>Start-Up Time.</b> (reach 90% amplitude and at +25°C $\pm 2$ °C)		2 m. sec. Typical, 3 m. sec. max.	
<b>Supply Voltage (V<sub>DD</sub>)</b>		+3.0 V (voltage code is "3")	+5.0 V (voltage code is "5")
<b>Output Voltage Level</b>		0.8 V p-p min.	1.0 V p-p min.
<b>Current Consumption</b>		9.6 ~ 13 MHz: 1.3 mA max. 13.1 ~ 20 MHz: 1.5 mA max. 20.1 ~ 26 MHz: 2.0 mA max.	9.6 ~ 13 MHz: 2.0 mA max. 13.1 ~ 20 MHz: 2.2 mA max. 20.1 ~ 26 MHz: 2.5 mA max.
<b>VCTCXO only</b>	<b>Electrical Frequency Tuning (from voltage control pin)</b>	$\pm 5 \sim \pm 12$ ppm for +1.5 V $\pm 1.0$ V (up to $\pm 100$ ppm is also available for some of the packages)	$\pm 6 \sim \pm 12$ ppm for +2.5 V $\pm 2.0$ V (up to $\pm 100$ ppm is also available for some of the packages)
	<b>Slope Polarity</b>	<b>Positive:</b> Increase control voltage increases output frequency. Negative slope is also available	
	<b>Linearity</b>	10 % max.	
<b>Output Load</b>		10 K $\Omega$ // 15 pF	
<b>Harmonics Distortion</b>		M57, M53, VM57, VM53: -10 dB typ. -7 dB max. Other models: -12 dB typ. -9 dB max.	
<b>Output Format</b>		DC block, AC coupled	
<b>Storage Temperature</b>		-40°C to +85°C	

**Note 1:** Depends on specific frequency, operating temperature range and package style, specifications may vary from model to model. Please contact Mercury if spec. sheet of a particular model is required.

**Note 2:** TCXO products ordered without mechanical and electrical frequency tuning should have a frequency tolerance of  $\pm 3$  ppm (at +25°C) and the frequency stability over temperature will be from that measured value.

# "TCXO" and "VCTCXO" Wave Form: Clipped Sine Wave



**MERCURY**  
Since 1973

## Wave Form – clipped sine wave

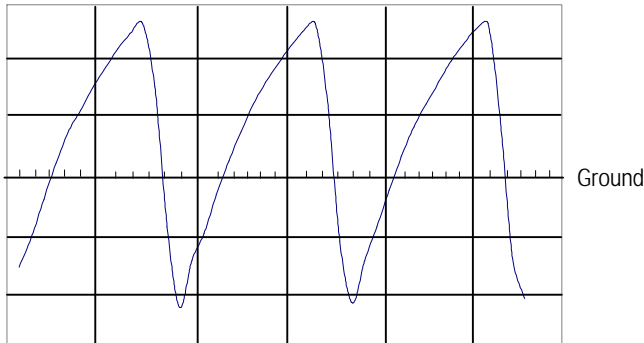

## Typical Phase Noise

VM53S3-13.000

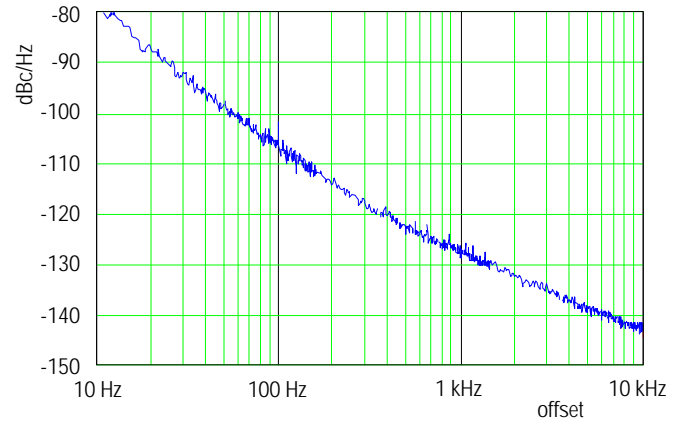

## Part Number Format and Examples:

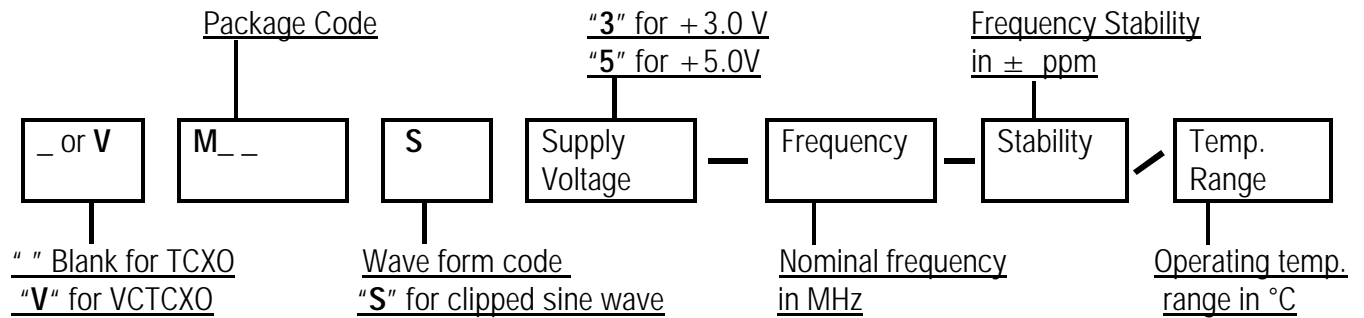

M38S5-12.800-1.0/-20+70 represents 12.800 MHz TCXO in M38 package with stability of  $\pm 1$  ppm from  $-20^{\circ}\text{C}$  to  $+70^{\circ}\text{C}$ , clipped sine wave output, +5.0V input voltage.

VM47S3-13.000-2.5/-30+75 represents 13.0 MHz VCTCXO in M47 package with stability of  $\pm 2.5$  ppm from  $-30^{\circ}\text{C}$  to  $+75^{\circ}\text{C}$ , clipped sine wave output, +3.0 V input voltage.

## Clipped Sine Wave TCXO (VCTCXO) Test Circuit:

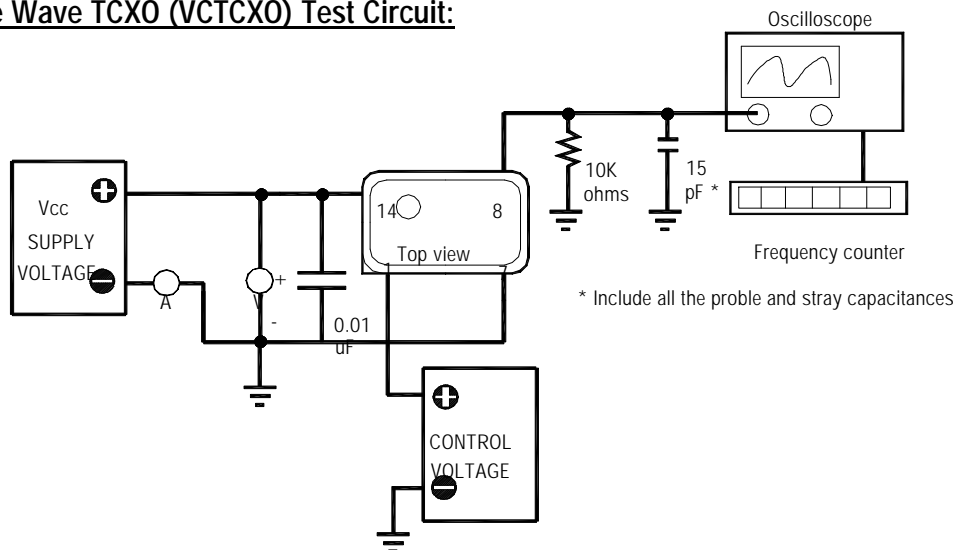

**Package: M38S,VM38S**

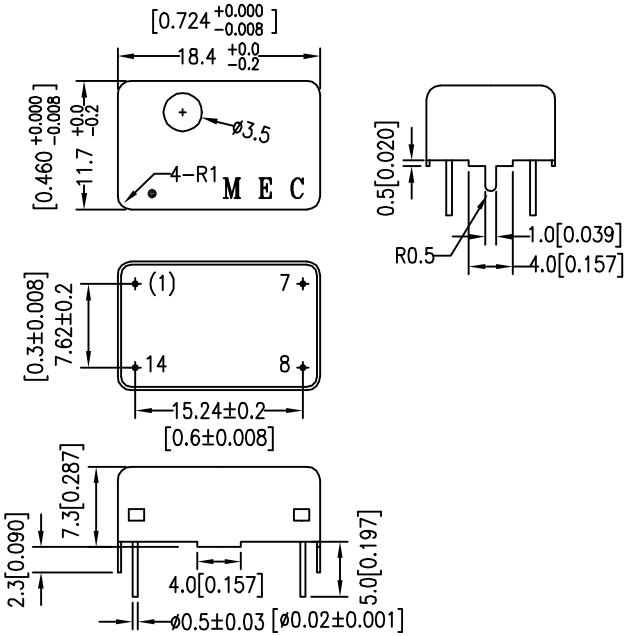

**Pin Connections**

- Pin 1: Voltage Control for VCTCXO; No physical pin 1 for TCXO
- Pin 7: Ground
- Pin 8: Output
- Pin 14: Supply Voltage

**Package: M39S,VM39S**

Unit: mm [inches]

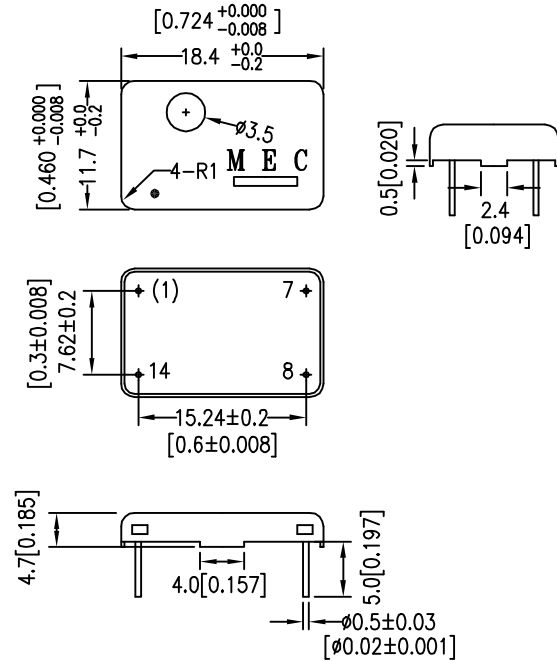

**Pin Connections**

- Pin 1: Voltage Control for VCTCXO; No physical pin 1 for TCXO
- Pin 7: Ground
- Pin 8: Output
- Pin 14: Supply Voltage

TCXO;VCTCXO

**Package: M47S,VM47S**

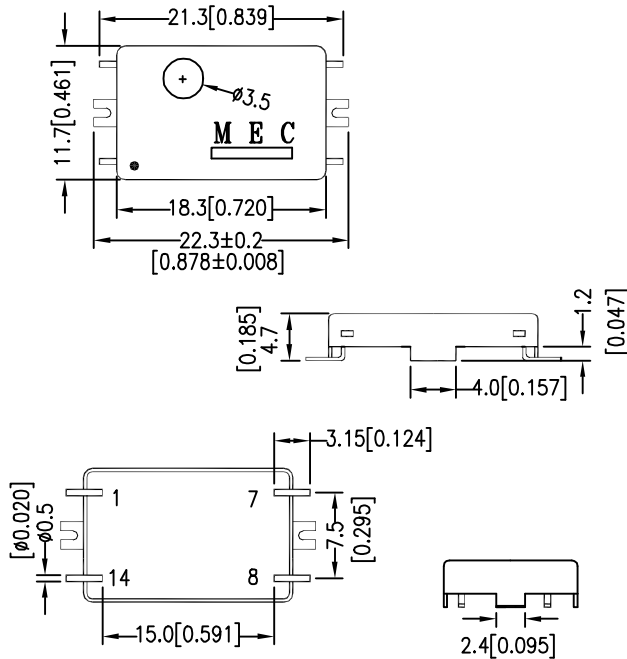

**Pin Connections**

- Pin 1: Voltage Control for VCTCXO. No Connection for TCXO.
- Pin 7: Ground
- Pin 8: Output
- Pin 14: Supply Voltage

**Package: M55S,VM55S**

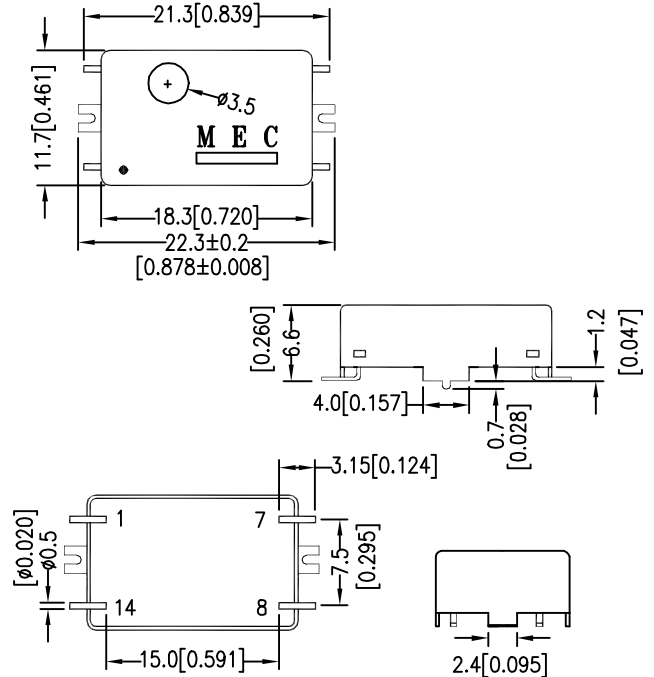

**Pin Connections**

- Pin 1: Voltage Control for VCTCXO. No Connection for TCXO.
- Pin 7: Ground
- Pin 8: Output
- Pin 14: Supply Voltage

**Package: M14S, VM14S Hermetically Sealed DIP  
No Trimmer Access**

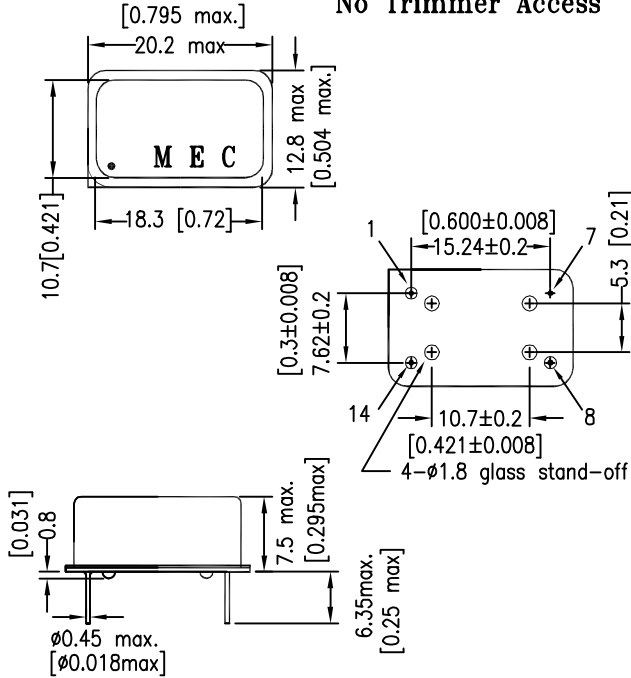

**Pin Connections** Square corner denotes pin 1  
 Pin 1: Voltage Control for VCTCXO; No Connection for TCXO  
 Pin 7: Ground  
 Pin 8: Output  
 Pin 14: Supply Voltage

**Package: M15S, VM15S**

Unit: mm [inches]

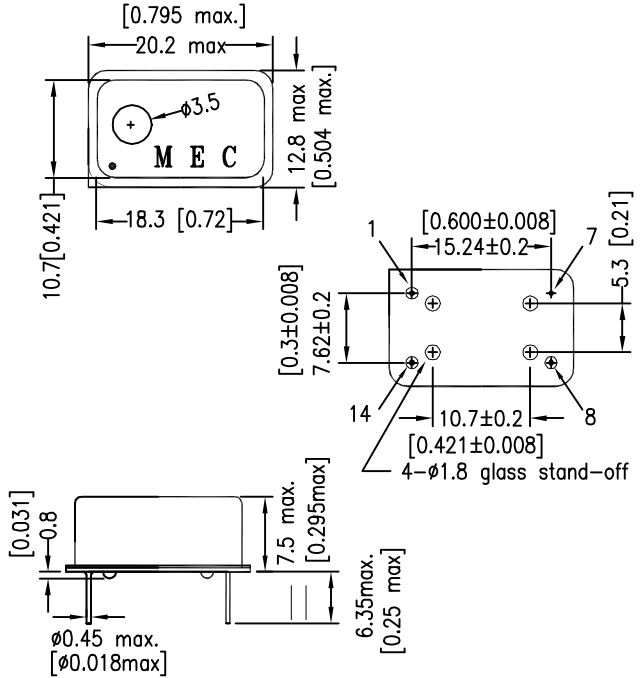

**Pin Connections** Square corner denotes pin 1  
 Pin 1: Voltage Control for VCTCXO; No Connection for TCXO  
 Pin 7: Ground  
 Pin 8: Output  
 Pin 14: Supply Voltage

TCXO;VCTCXO

**Package: M24S, VM24S**

**Hermetically sealed  
No trimmer access**

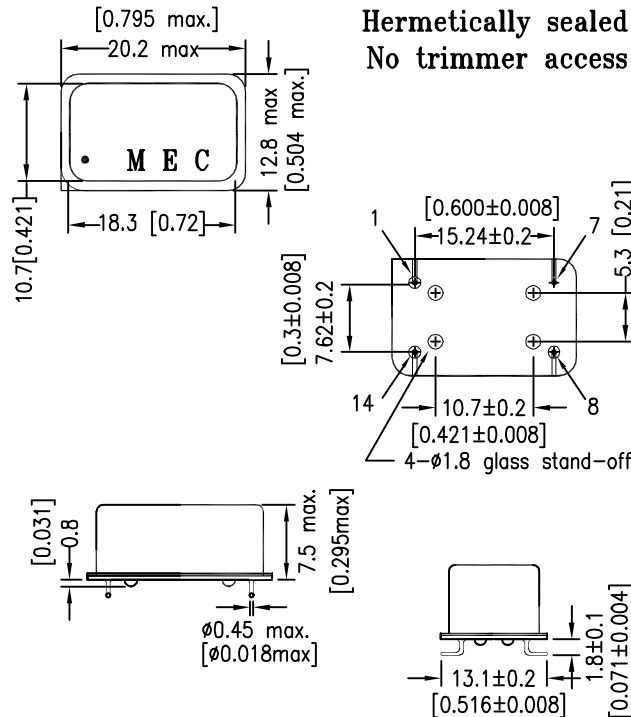

**Pin Connections** Square corner denotes pin 1  
 Pin 1: Voltage Control for VCTCXO; No Connection for TCXO  
 Pin 7: Ground  
 Pin 8: Output  
 Pin 14: Supply Voltage

**Package: M25S, VM25S**

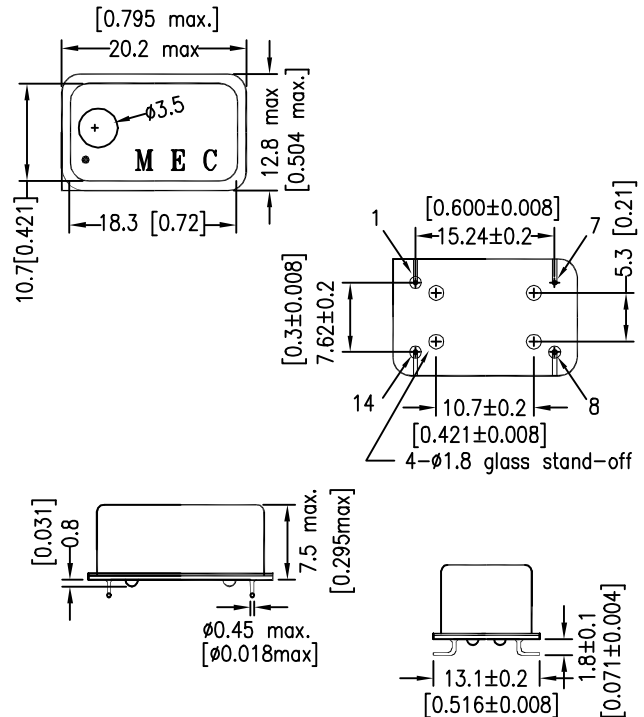

**Pin Connections** Square corner denotes pin 1  
 Pin 1: Voltage Control for VCTCXO; No Connection for TCXO  
 Pin 7: Ground  
 Pin 8: Output  
 Pin 14: Supply Voltage

Package: M8S, VM8S

Unit: mm [inches]

Hermetically Sealed DIP  
No trimmer Access

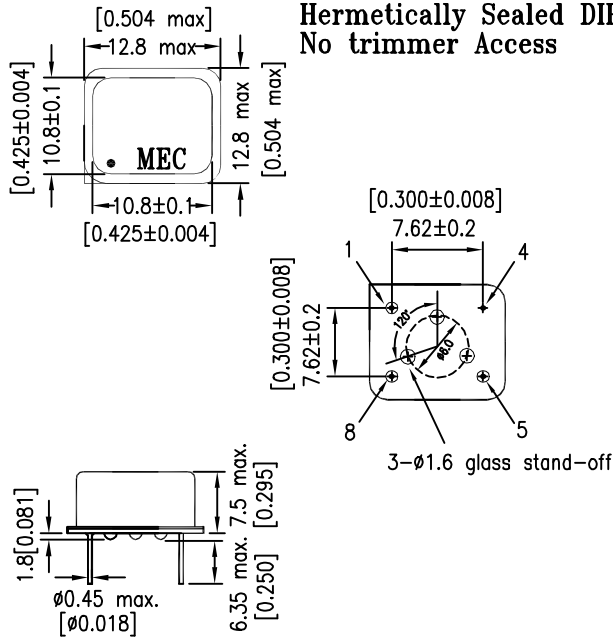

**Pin Connections**

Square corner denotes pin 1

- Pin 1: Voltage Control for VCTCXO or No Connection for TCXO
- Pin 4: Ground
- Pin 5: Output
- Pin 8: Supply Voltage

Package: M28S, VM28S

Hermetically Sealed DIP  
No trimmer Access

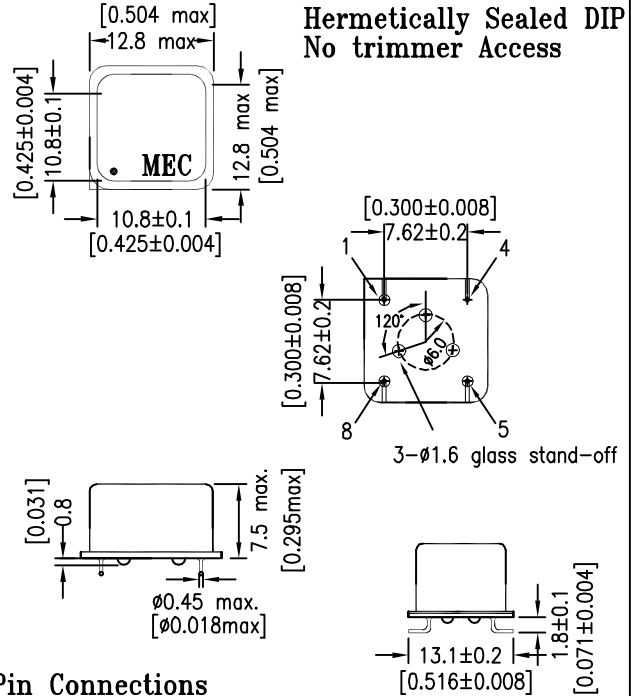

**Pin Connections**

- Pin 1: Voltage Control for VCTCXO or No Connection for TCXO
  - Pin 4: Ground
  - Pin 5: Output
  - Pin 8: Supply Voltage
- Square corner denotes pin 1

TCXO;VCTCXO

Package: M42S, VM42S

"42" represents 4 pads and 2.5 mm overall height

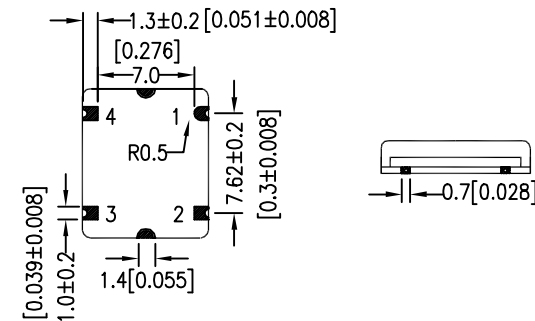
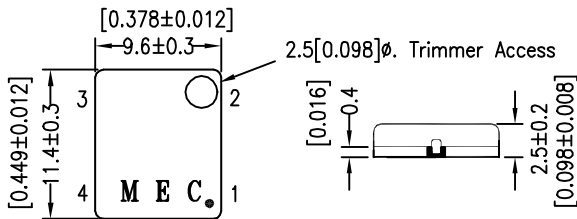

**Pad Connections:**

- Pad 1: Voltage Control for VCTCXO; No Connection for TCXO
- Pad 2: Ground
- Pad 3: Output
- Pad 4: Supply Voltage

Package: M62S, VM62S

"62" represents 6 pads and 2.5 mm overall height

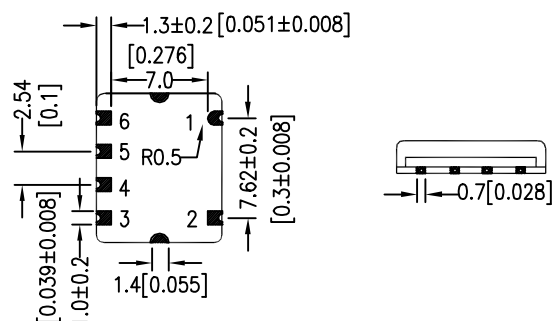
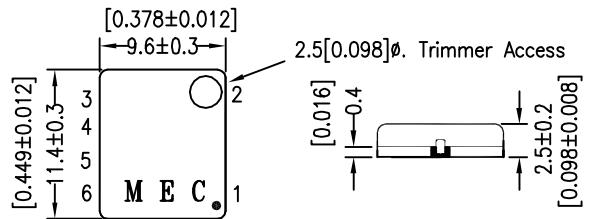

**Pad Connections:**

- Pad 1,2,4: Ground
- Pad 3: Output
- Pad 5: Voltage Control for VCTCXO; No Connection for TCXO
- Pad 6: Supply Voltage

**Package: M44S, VM44S**

"44" represents 4 pads and 4.7 mm overall height

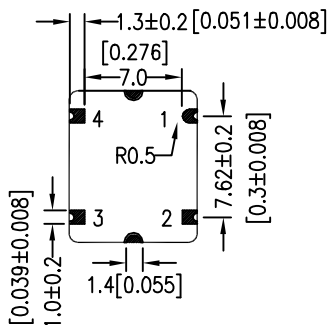
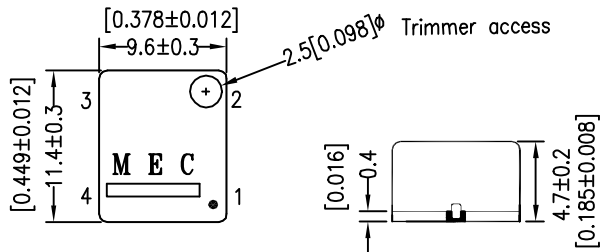

**Pad Connections:**

- Pad 1: Voltage Control for VCTCXO; No Connection for TCXO
- Pad 2: Ground
- Pad 3: Output
- Pad 4: Supply Voltage

**Package: M64S, VM64S**

"64" represents 6 pads and 4.7 mm overall height

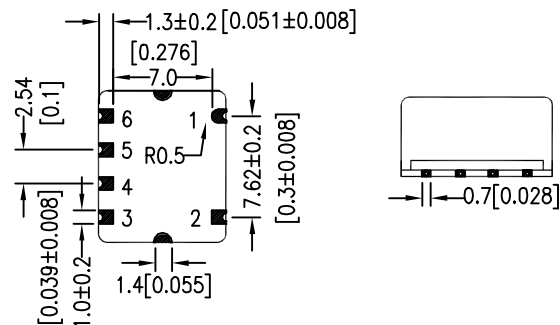
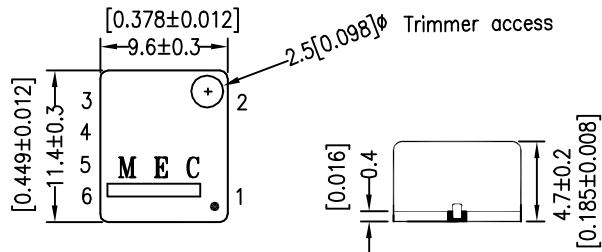

**Pad Connections:**

- Pad 1,2,4: Ground
- Pad 3: Output
- Pad 5: Voltage Control for VCTCXO; No Connection for TCXO
- Pad 6: Supply Voltage

TCXO;VCTCXO

**Package: M57S, VM57S**

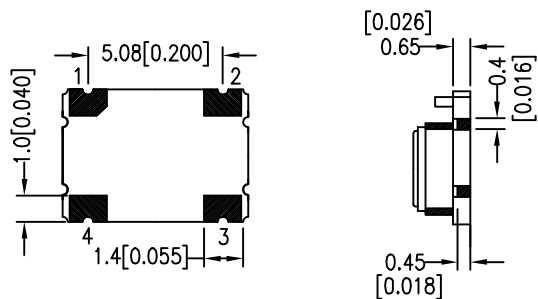
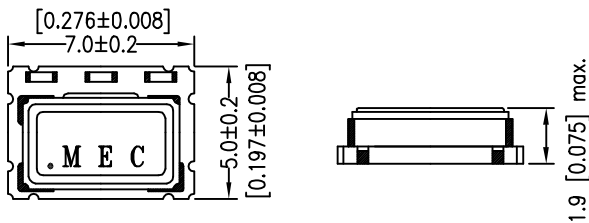

**Pad Connections:**

- Pad 1: Ground for TCXO; Voltage Control for VCTCXO
- Pad 2: Ground
- Pad 3: Output
- Pad 4: Supply Voltage

Unit: mm [inches]

**Package: M53S, VM53S**

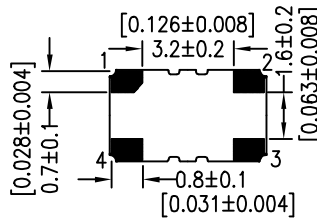
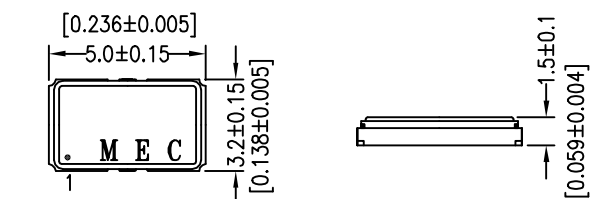

**Pad Connections:**

- Pad 1: Ground for TCXO; Voltage Control for VCTCXO
- Pad 2: Ground
- Pad 3: Output
- Pad 4: Supply Voltage

**Package: M19S, VM19S**

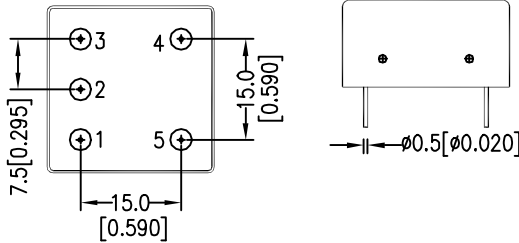
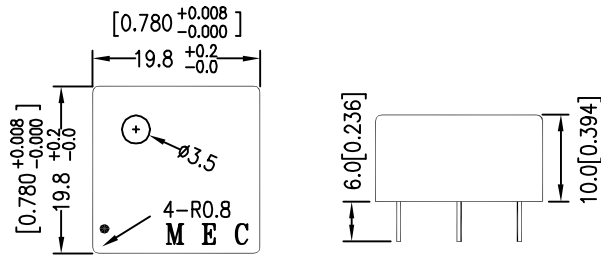

**Pin Connections**

- Pin 1: Supply Voltage
- Pin 2: Output
- Pin 3: Ground
- Pin 4: Voltage Control for VCTCXO; No Connection for TCXO
- Pin 5: No Connection

**Package: M48S, VM48S**

Unit: mm [inches]

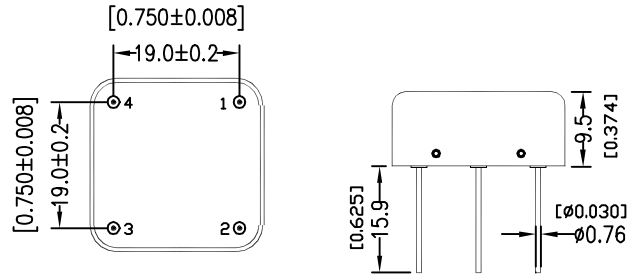
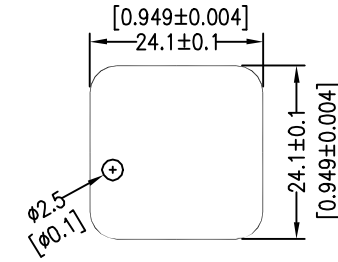

Bottom view

**Pin Connections:**

- Pin 1: Supply Voltage
- Pin 2: No connection for TCXO; Voltage Control for VCTCXO
- Pin 3: Ground
- Pin 4: Output

TCXO;VCTCXO

**Package: M58S, VM58S**

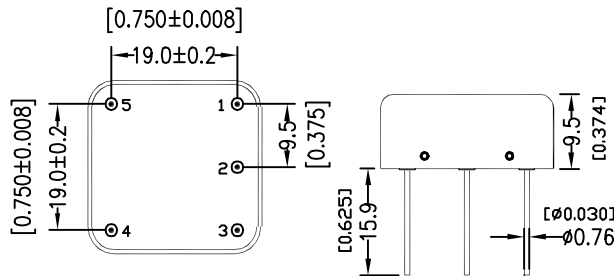
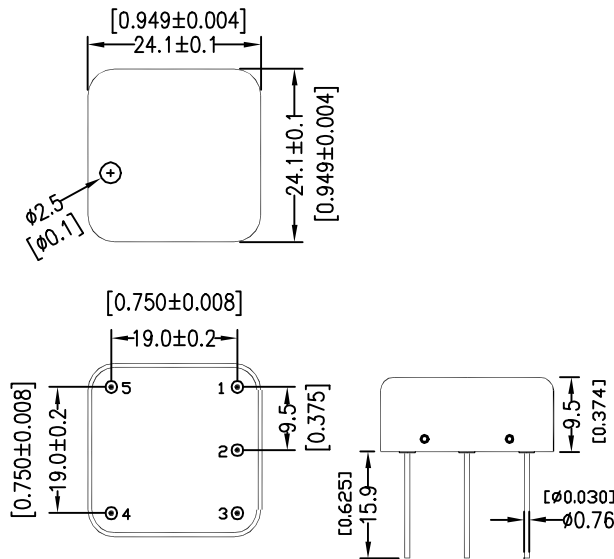

Bottom view

**Pin Connections:**

- Pin 1: Output
- Pin 2: Ground
- Pin 3: No connection for TCXO; Voltage Control for VCTCXO
- Pin 4: Reference Voltage Output
- Pin 5: Supply Voltage

**Package: M78S, VM78S**

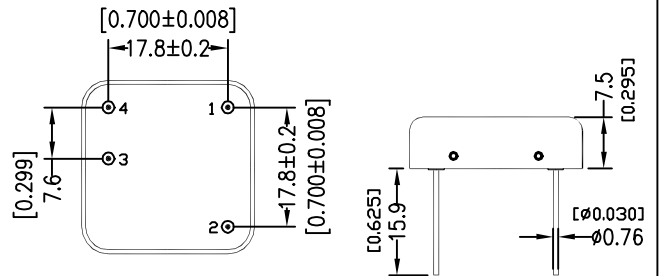
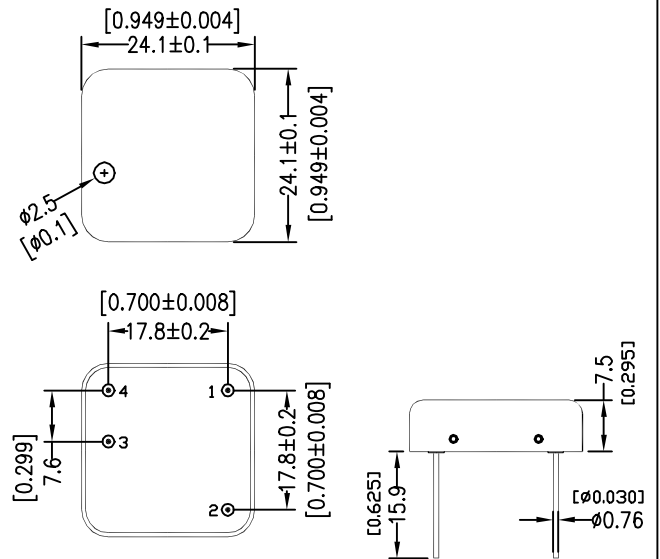

Bottom view

**Pin Connections:**

- Pin 1: Output
- Pin 2: No connection for TCXO; Voltage Control for VCTCXO
- Pin 3: Ground
- Pin 4: Supply Voltage