

ALUMINUM ELECTROLYTIC CAPACITORS



ZG 3.95mmL MAX. Chip Type,
Wide Temperature Range
series



- Chip type with 3.95mmLMAX height. Operating over wide temperature range of -40 to +105°C.
- Designed for surface mounting on high density PC board.
- Applicable to automatic mounting machine fed with carrier tape.
- Compliant to the RoHS directive (2002/95/EC).

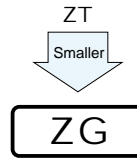

Specifications

Item	Performance Characteristics								
Category Temperature Range	-40 to +105°C								
Rated Voltage Range	6.3 to 50V								
Rated Capacitance Range	0.1 to 100μF								
Capacitance Tolerance	±20% at 120Hz, 20°C								
Leakage Current	After 2 minutes' application of rated voltage, leakage current is not more than 0.01 CV or 3 (μA) , whichever is greater.								
Tangent of loss angle (tan δ)	Rated voltage (V)	6.3	10	16	25	35	50	120Hz 20°C	
	tan δ (MAX.)	0.38	0.32	0.20	0.16	0.14	0.14		
Stability at Low Temperature	Rated voltage (V)	6.3	10	16	25	35	50	120Hz	
	Impedance ratio Z-25°C / Z+20°C	6	5	3	3	3	3		
	ZT / Z20 (MAX.) Z-40°C / Z+20°C	10	10	6	6	4	4		
Endurance	The specifications listed at right shall be met when the capacitors are restored to 20°C after the rated voltage is applied for 1000 hours at 105°C.							Capacitance change	Within ±30% of the initial capacitance value
								tan δ	300% or less than the initial specified value
								Leakage current	Less than or equal to the initial specified value
Shelf Life	After storing the capacitors under no load at 105°C for 1000 hours and then performing voltage treatment based on JIS C 5101-4 clause 4.1 at 20°C, they shall meet the specified values for the endurance characteristics listed above.								
Resistance to soldering heat	The capacitors are kept on a hot plate for 30 seconds, which is maintained at 250°C. The capacitors shall meet the characteristic requirements listed at right when they are removed from the plate and restored to 20°C.							Capacitance change	Within ±10% of the initial capacitance value
								tan δ	Less than or equal to the initial specified value
								Leakage current	Less than or equal to the initial specified value
Marking	Black print on the case top.								

Chip Type

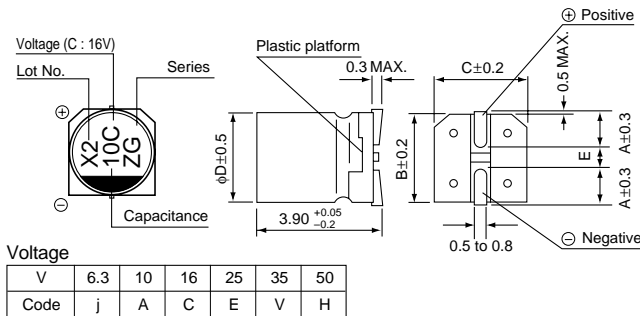

Type numbering system (Example : 16V 10μF)

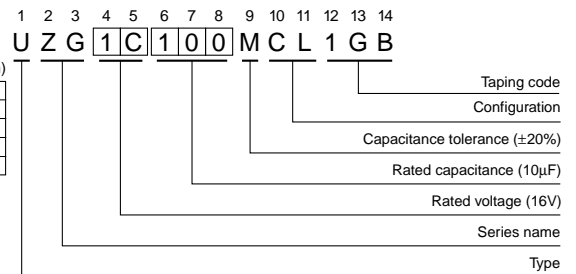

Dimensions

Cap. (μF)	V		6.3		10		16		25		35		50	
	Code		0J		1A		1C		1E		1V		1H	
0.1	0R1												4	0.9
0.22	R22												4	2.2
0.33	R33												4	2.8
0.47	R47												4	3.3
1	010												4	5.4
2.2	2R2												4	9.6
3.3	3R3												4	12
4.7	4R7								4	11	4	13	5	16
10	100						4	16	5	20	5	22	6.3	26
22	220	4	19	5	24	5	26	6.3	33	6.3	36			
33	330	5	26	5	30	6.3	35	6.3	42					
47	470	5	32	6.3	40	6.3	44							
100	101	6.3	52											

Rated ripple current (mArms) at 105°C 120Hz

Frequency coefficient of rated ripple current

Frequency	50 Hz	120 Hz	300 Hz	1 kHz	10 kHz or more
Coefficient	0.70	1.00	1.17	1.36	1.50

- Taping specifications are given in page 23.
- Recommended land size soldering by reflow are given in page 18,19.
- Please refer to page 3 for the minimum order quantity.

CAT.8100Y