

Lamps > HALOGEN > MV ALUMINIUM REFLECTOR > TWISTLine Alu



Features

Quartz burner with Lambda-shape filament optically positioned in a hard-coated aluminium-coated reflector

Aluminium-coated version (GU10 lamp base) directs most of its heat to the front

No light goes to the back of the reflector

Clear front glass protects against touching the burner and against dust/moisture

Distinct MR16 look

High and stable light output throughout lifetime

GU10 bases ensure good retention in the luminaire and easy, twist and take out; insertion and replacement

Built-in double fuses for additional safety at end-of-life

Lifetime: 2000 hours

Description

Mains-voltage 50 mm diameter reflector lamp with aluminium reflector

Application

Typically used for accent lighting in homes

Also used in accent and general lighting in shops, hotels, restaurants, bars etc.

Benefits

Lamp can be connected directly to the mains supply, so no transformers are needed

UV-Block lamp so no additional front glass or UV filter required

Twistline dichroic and aluminium versions are the most compact lamps of their kind available

Luminaires

Conforms to IEC 598 for use in open luminaires The luminaire must carry instructions about which lamp should be used (GU10/aluminium)

Packaging Information

Consumer Unit (EAN1)						Box (EAN3)				
Commercial Code	Product Description	Unit	EAN Code 1	Pieces	Dimensions in cm (L x H x W)	EAN Code 3	Pieces	Dimensions in cm (L x H x W)		
				Per						
				Per						
14602	TWIST ALU 50W GU10 230V 25D 1CT/10X5F	PCE	8711500412508	1		8711500412522	50	32.8 x 11.5 x 24.6		
14602	TWIST ALU 50W GU10 230V 25D 1CT/10X5F	PCE	8711500428479	1		8711500428493	50	32.8 x 11.5 x 24.6		
14603	TWIST ALU 50W GU10 230V 50D 1CT/10X5F	PCE	8711500412584	1		8711500412607	50	32.8 x 11.5 x 24.6		
14603	TWIST ALU 50W GU10 230V 50D 1CT/10X5F	PCE	8711500428530	1		8711500428554	50	32.8 x 11.5 x 24.6		
14604	TWIST ALU 50W GU10 240V 25D 1CT/10X5F	PCE	8711500412539	1		8711500412577	50	32.8 x 11.5 x 24.6		
14604	TWIST ALU 50W GU10 240V 25D 1CT/10X5F	PCE	8711500428509	1		8711500428523	50	32.8 x 11.5 x 24.6		
14605	TWIST ALU 50W GU10 240V 50D 1CT/10X5F	PCE	8711500412614	1		8711500412645	50	32.8 x 11.5 x 24.6		
14605	TWIST ALU 50W GU10 240V 50D 1CT/10X5F	PCE	8711500428561	1		8711500428585	50	32.8 x 11.5 x 24.6		

Technical Product Information

Commercial Code	Product Description	Volt (V)	Watt	Finish	Cap	Color	Color Descriptions	Lumen	Beam	CRI	Avg.
			(W)			Temp.		(Lm)	Angle	(Ra)	Life
						(K)			(°)		Hours
14602	TWIST ALU 50W GU10 230V 25D 1CT/10X5F										
14602	TWIST ALU 50W GU10 230V 25D 1CT/10X5F	230	50	CL	GU10	2800		1000	25	100	
14603	TWIST ALU 50W GU10 230V 50D 1CT/10X5F	230	50	CLEAR					50		
14603	TWIST ALU 50W GU10 230V 50D 1CT/10X5F	230	50	CLEAR	GU10	2800		1000	50	100	
14604	TWIST ALU 50W GU10 240V 25D 1CT/10X5F										
14604	TWIST ALU 50W GU10 240V 25D 1CT/10X5F	240	50	CL	GU10	2800		1000	25	100	
14605	TWIST ALU 50W GU10 240V 50D 1CT/10X5F	240	50	CLEAR					50		
14605	TWIST ALU 50W GU10 240V 50D 1CT/10X5F	240	50	CLEAR	GU10	2800		1000	50	100	

Dimension Diagram

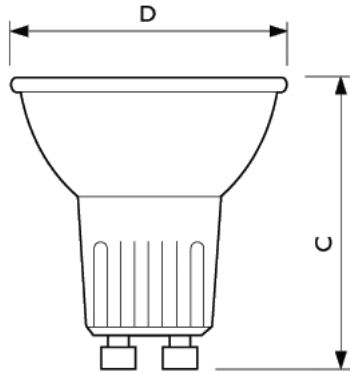

Type	C	D
14602	51	51
14603	53	50
14603	53	50
14604	51	51
14605	53	50
14605	53	50