

Technical data

Mounting and operating instructions

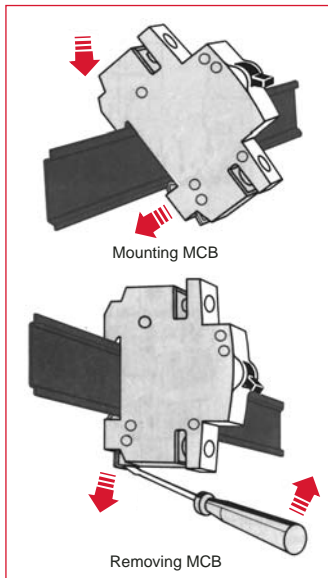

Mounting

Universal mounting position using snap-on mounting to standard 35x7.5mm DIN rail.

Miniature circuit breakers (MCBs) can also be mounted to front of door using a panel cut-out with breaker handle protruding through panel opening for external operation. Special front mounting kit type ME is available (see page 2.12).

Connection

Terminals are suitable for solid or flexible conductors from 18 to 4 AWG (0.75 to 25mm²) with no busbar connected. When maximum busbar size of 36 mm² is used, maximum cable is 6 AWG (16 mm²).

Maximum tightening torque of 17.5 in-lb (2 Nm) for line/load terminals and 4.5 in-lb (0.5Nm) for accessory device terminals.

Operation

MCBs are switched on by moving the handle to the upper position. Stamped onto the handle switch, a "I" is visible confirming that the breaker is closed.

The MCBs are "trip-free," if the handle is being forced to the "ON" position, the breaker will still trip under fault conditions.

The "O" marking indicates that the breaker is in the "OFF" position. The MCB is now open and the load is disconnected from line power.

When a breaker has tripped, the MCB handle should first be set to the full "OFF" position to make certain the trip mechanism has been reset. Once the fault has been determined and cleared the MCB can again be switched "ON".

Maintenance

ABB miniature circuit breakers require no special maintenance; only normal electrical system maintenance procedures are required.

Possible mounting arrangements of MCB accessories

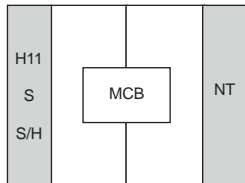

Auxiliary switch/bell alarm neutral disconnect

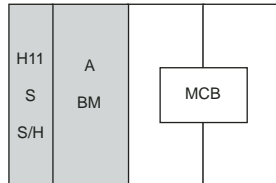

Shunt trip or undervoltage release mounted with auxiliary switch

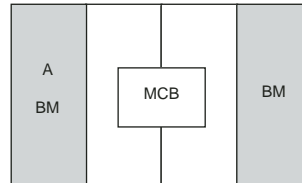

Shunt trip and/or undervoltage release

Auxiliary switch

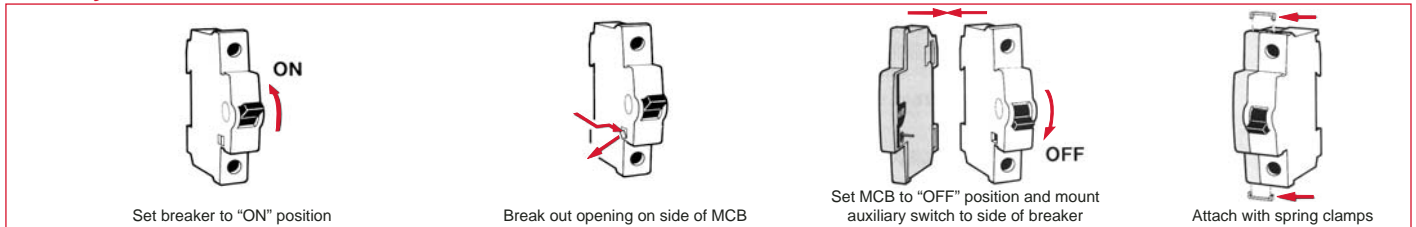

Bell alarm with auxiliary contact

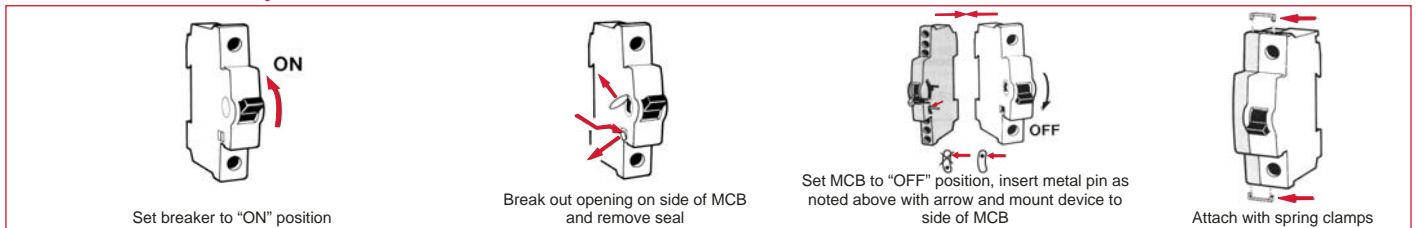

Shunt trip and undervoltage release

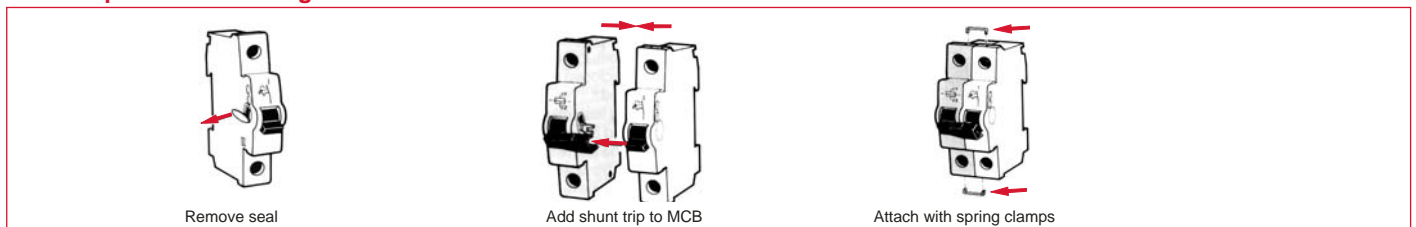

Technical data

Busbars & connectors

Connection methods

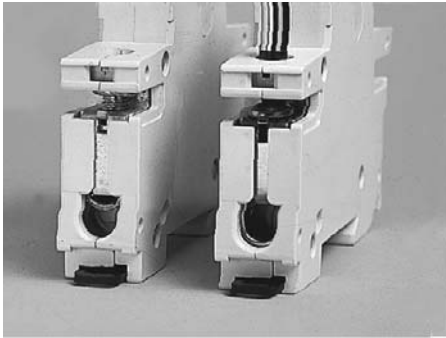

Dual function terminals provided in open position for connection to busbars. Pressing on screw head opens box terminal for cable insertion. Only the lower terminal is dual function.

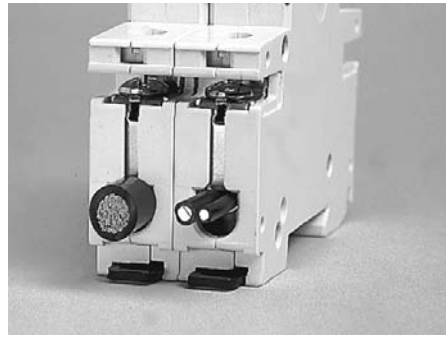

Terminals allow for connection of cable 18-4 AWG. Conductors of different sizes may also be used in same terminal.

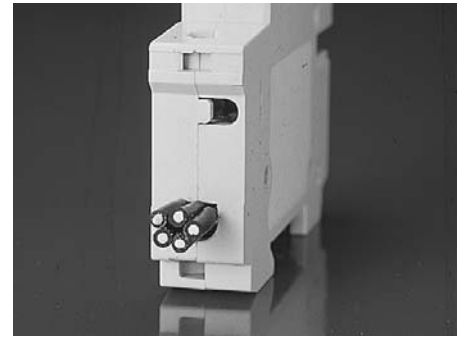

Up to five conductors, 16 AWG each, can be safely connected per terminal.

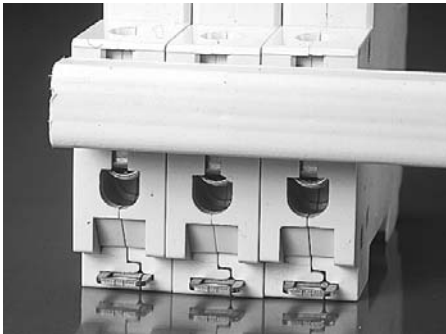

Lower terminals can be bussed together with single phase or multi-phase busbars as shown. Upper terminals can also be busbar connected.

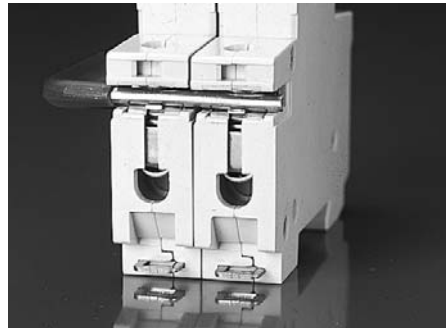

Lower terminal can also be bussed with solid round conductor.

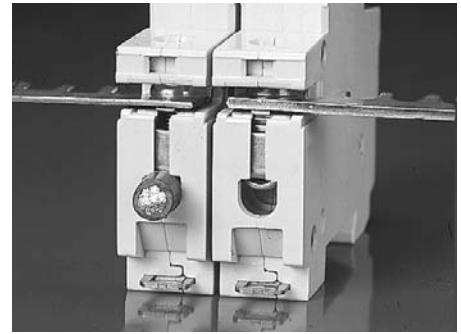

Cables can be connected to box terminals in addition to busbar connections on lower, dual function terminals.

Technical data

S260, S270, & S280



Item	S260-B		S260-C, -D		S270-K		S280-K	
Approvals:	1077		1077		1077		1077	
UL	C22.2 — No.235		C22.2 — No. 235		C22.2 — No. 235		—	
CSA	0641, 0660		0660		0660		0660	
VDE	898, 947		898, 947		898, 947		898, 947	
IEC	—		—		—		—	
No. of poles:	1,2,3,4 1+N,3+N		1,2,3		1,2,3,4, 1+N,3+N		1,2,3,4,1+N,3+N	
Tripping characteristic:	B		C,D		K		K	
Rated currents:	6 to 63A		0.5 to 63A		0.5 to 63A		0.2 to 63A	
Minimum operating voltage:	12V		12V		12V		12V	
UL/CSA rated voltage & interrupting capacity	Single pole	Multi pole	Single pole	Multi pole	Single pole	Multi pole	Single pole	Multi pole
120VAC	10kA	—	10kA	—	10kA	—	10kA for 0.2-40A 6kA for 50-63A	—
240VAC	6kA	10kA	6kA	10kA	6kA	10kA	10kA for 0.2-40A 6kA for 50-63A	10kA for 0.2-32A 6kA for 40-63A
277VAC	6kA	—	6kA	—	6kA	—	10kA for 0.2-40A	—
277/480 VAC	—	6kA	—	6kA	—	6kA	—	10kA
60VDC	10kA	10kA	10kA	10kA	10kA	10kA	—	—
125VDC	—	10kA	—	10kA	—	10kA	—	—
Frequency:	50/60Hz (See below)		50/60Hz (see below)		50/60Hz (see below)		50/60Hz (see below)	
Rated voltage	240/415VAC		240/415VAC		240/415VAC		240/415VAC	
IEC single pole	60VDC		60VDC		60VDC		60VDC	
IEC multi-pole	415VAC		415VAC		415VAC		415VAC	
	110VDC		110VDC		110VDC		110VDC	
Protection category:	IP20		IP20		IP20		IP20	
Depth of unit per DIN 43880:	68mm		68mm		68mm		68mm	
Mounting position:	optional		optional		optional		optional	
Standard mounting:	35mm DIN rail		35mm DIN rail		35mm DIN rail		35mm DIN rail	
Main and shunt trip terminals:	6-40A 18-4 AWG		0.5-40A 18-4 AWG		0.5-40A 18-4 AWG		0.2-40A 18-4 AWG	
Wire size	50A & above 18-2 AWG		50A & above 18-2 AWG		50A & above 18-2 AWG		50A & above 18-2 AWG	
Torque	17.5 in-lbs.		17.5 in-lbs.		17.5 in-lbs.		17.5 in-lbs.	
Tool	#2 Posidrive		#2 Posidrive		#2 Posidrive		#2 Posidrive	
Accessory terminals	18-16 AWG		18-16 AWG		18-16 AWG		18-16 AWG	
Wire size	4.5 in-lbs.		4.5 in-lbs.		4.5 in-lbs.		4.5 in-lbs.	
Torque	#1 Posidrive		#1 Posidrive		#1 Posidrive		#1 Posidrive	
Tool	—		—		—		—	
Service life at rated load:	$I_n < 32$ A, 20,000 operations $I_n > 32$ A, 10,000 operations		$I_n < 32$ A, 20,000 operations $I_n > 32$ A, 10,000 operations		$I_n < 32$ A, 20,000 operations $I_n > 32$ A, 10,000 operations		$I_n < 32$ A, 20,000 operations $I_n > 32$ A, 10,000 operations	
Ambient temperatures:	-25°C to +55°C		-25°C to +55°C		-25°C to +55°C		-25°C to +55°C	
Storage temperatures	-40°C to +70°C		-40°C to +70°C		-40°C to +70°C		-40°C to +70°C	
Shock resistance:	30g minimum of 2 impacts, shock duration of 13ms		30g minimum of 2 impacts, shock duration of 13ms		30g minimum of 2 impacts, shock duration of 13ms		30g minimum of 2 impacts, shock duration of 13ms	
Vibration resistance:	5g, 20 cycles, 5 Hz, 150 Hz @ 0.8 - I_n		5g, 20 cycles, 5 Hz, 150 Hz @ 0.8 - I_n		5g, 20 cycles, 5 Hz, 150 Hz @ 0.8 - I_n		5g, 20 cycles, 5 Hz, 150 Hz @ 0.8 - I_n	
Disconnecting neutral rating:	6kA switching		6kA switching		6kA switching		—	

Influence of frequency on electro-magnetic trips

Magnetic trip values shown on trip curves are valid for 50/60Hz applications. For frequencies other than 50/60Hz, the magnetic (instantaneous) trip values are increased by the factor given below:

	16 2/3 - 60Hz	100Hz	200Hz	400Hz	DC
Approx. factor	1	1.1	1.2	1.5	1.5

Thermal tripping is independent of frequency.

Ⓞ Available for purchase. See page 14.19.



Technical data S280, S280UC, S290

Item	S280UC-K		S280-Z		S280UC-Z		S290-C	
Approvals:								
UL	1077		1077		1077		—	
CSA	—		—		—		—	
VDE	0660		0660		0660		0660	
IEC	898,947		898, 947		898, 947		898	
No. of poles:	1,2,3		1,2,3,4		1,2,3		1,2,3,4	
Tripping characteristic:	K		Z		Z		C	
Rated currents:	0.2 to 63A		0.5 to 63A		0.5 to 63A		80 to 125A	
Minimum operating voltage:	12V		12V		12V		12V	
UL/CSA rated voltage & interrupting capacity	Single pole	Multi pole	Single pole	Multi pole	Single pole	Multi pole		
120VAC	6kA for 0.2-40A 5kA for 50-63A	—	10kA for 0.2-40A 6kA for 50-63A	—	6kA for 0.2-40A 5kA for 50-63A	—	—	
240VAC	6kA for 0.2-40A 5kA for 50-63A	6kA for 0.2-40A 5kA for 50-63A	10kA for 0.2-40A 6kA for 50-63A	10kA for 0.2-32A 6kA for 40-63A	6kA for 0.2-40A 5kA for 50-63A	6kA for 0.2-40A 5kA for 50-63A	—	
277VAC	4.5kA for 0.2-40A 5kA for 50-63A	—	10kA for 0.2-40A 6kA for 50-63A	—	4.5kA for 0.2-40A 5kA for 50-63A	—	—	
277/480 VAC	—	4.5kA for 0.2-40A 5kA for 50-63A	—	10kA	—	4.5kA for 0.2-40A 5kA for 50-63A	—	
60VDC	10kA	10kA	—	—	10kA	10kA	—	
125VDC	10kA	10kA	—	—	10kA	10kA	—	
250VDC	4.5kA	4.5kA	—	—	4.5kA	4.5kA	—	
500VDC	—	4.5kA	—	—	—	4.5kA	—	
Frequency:	50/60Hz (see below)		50/60 Hz (see below)		50/60Hz (see below)		50/60Hz (see below)	
Rated voltage								
IEC single pole	240/415VAC 220VDC		240/415VAC 60VDC		240/415VAC 220VDC		230/440VAC 60VDC	
IEC multi-pole	415VAC 440VDC		415VAC 110VDC		415VAC 440VDC		440VAC 110VDC	
Protection category:	IP20		IP20		IP20		IP20	
Depth of unit per DIN 43880:	68mm		68mm		68mm		70mm	
Mounting position:	optional		optional		optional		optional	
Standard mounting:	35mm DIN rail		35mm DIN rail		35mm DIN-rail		35mm DIN-rail	
Main and shunt trip terminals:								
Wire size	0.2-40A 50A & above	18-4 AWG 18-2 AWG	0.5-40A 50A & above	18-4 AWG 18-2 AWG	0.5-40A 50A & above	18-4 AWG 18-2 AWG	80-125A	14-1/0 AWG
Torque	17.5 in.-lbs.		17.5 in.-lbs.		17.5 in.-lbs.		17.5 in.-lbs.	
Tool	#2 Posidrive		#2 Posidrive		#2 Posidrive		#2 Posidrive	
Accessory terminals								
Wire size	18-16 AWG		18-16 AWG		18-16 AWG		18-16 AWG	
Torque	4.5 in.-lbs.		4.5 in.-lbs.		4.5 in.-lbs.		4.5 in.-lbs.	
Tool	#1 Posidrive		#1 Posidrive		#1 Posidrive		#1 Posidrive	
Service life at rated load:	$I_n < 32 A$, 20,000 operations $I_n > 32 A$, 10,000 operations		$I_n < 32 A$, 20,000 operations $I_n > 32 A$, 10,000 operations		$I_n < 32 A$, 20,000 operations $I_n > 32 A$, 10,000 operations		10,000 operations —	
Ambient temperatures:	-25°C to +55°C		-25°C to +55°C		-25°C to +55°C		-5°C to +45°C	
Storage temperatures	-40°C to +70°C		-40°C to +70°C		-40°C to +70°C		-40°C to +70°C	
Shock resistance:	30g minimum of 2 impacts, shock duration of 13ms		30g minimum of 2 impacts, shock duration of 13ms		30g minimum of 2 impacts, shock duration of 13ms		30g minimum of 2 impacts, shock duration of 13ms	
Vibration resistance:	5g, 20 cycles, 5 Hz, 150 Hz @ 0.8 - I_n		5g, 20 cycles, 5 Hz, 150 Hz @ 0.8 - I_n		5g, 20 cycles, 5 Hz, 150 Hz @ 0.8 - I_n		60m/s ² , at 10 - 150 Hz	

Influence of frequency on electro-magnetic trips

Magnetic trip values shown on trip curves are valid for 50/60Hz applications. For frequencies other than 50/60Hz, the magnetic (instantaneous) trip values are increased by the factor given below:

	16 2/3 - 60Hz	100Hz	200Hz	400Hz	DC
Approx. factor	1	1.1	1.2	1.5	1.5

Thermal tripping is independent of frequency.

Technical data

Let-through values

Description

All ABB miniature circuit breakers substantially reduce the maximum let-through current from the peak available short circuit current.

- I_K - RMS current of fault
- I_D - Max let-through of MCB
- V - System voltage
- V_n - Arc voltage of MCB
- t_k - Breaking time of MCB

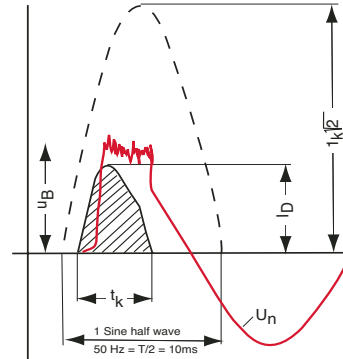

Let-through values I²t

S260-B

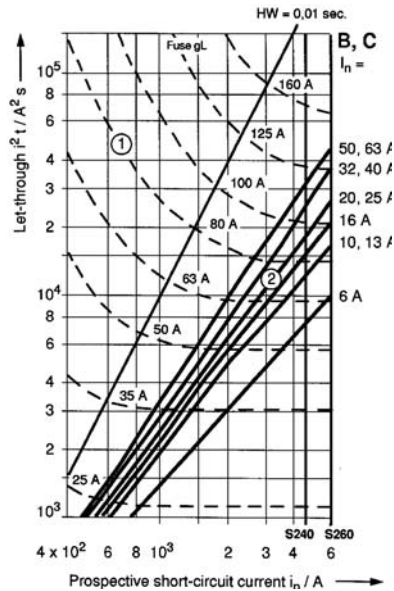

S270-K

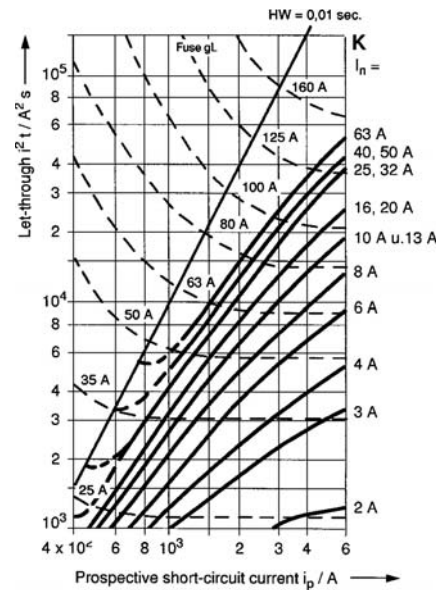

S280-K

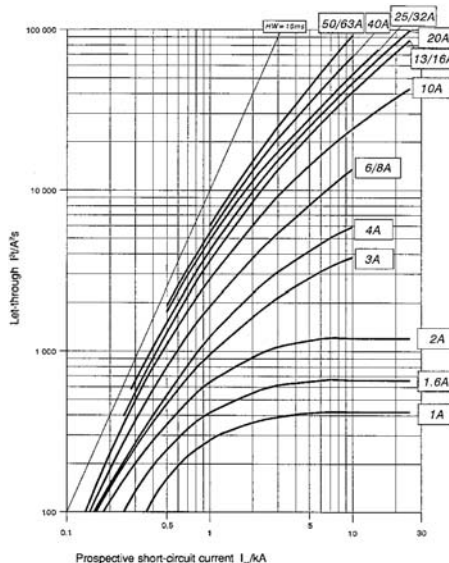

For other curves, please contact ABB Control.

Version	I ² t	I _{Peak}
S260B	TD9980	—
S260C	TD9981	—
S260D	TD9982	—
S270K	TD9972	TD9950
S280K	TD9978	—
S280Z	TD9979	—
S290C	TD9985	—
Version	Amps	Time-current trip
S260B	6 - 63	TD9725
S270K	0.5 - 8	TD9705
	10 - 40	TD9706
	50 - 63	TD9707
S280K	0.2 - 8	TD9708
	10 - 40	TD9709
	50 - 63	TD9710
S280Z	0.5 - 63	TD9711

Technical data

Temperature derating factors

Terminal markings

Type B, C, D

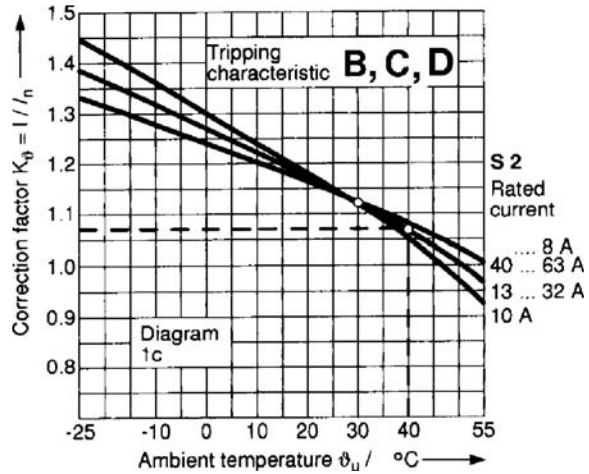

Type K, Z

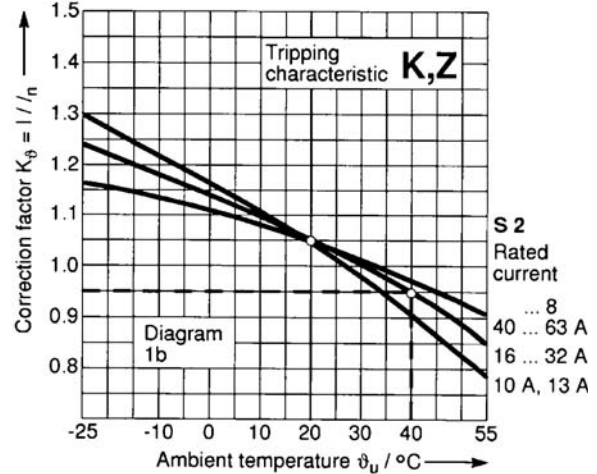

Current carrying capacity of type "B", "C", "D", "K" and "Z" thermal trip characteristics as a function of ambient temperature.

Terminal markings

Input optional from top or bottom.

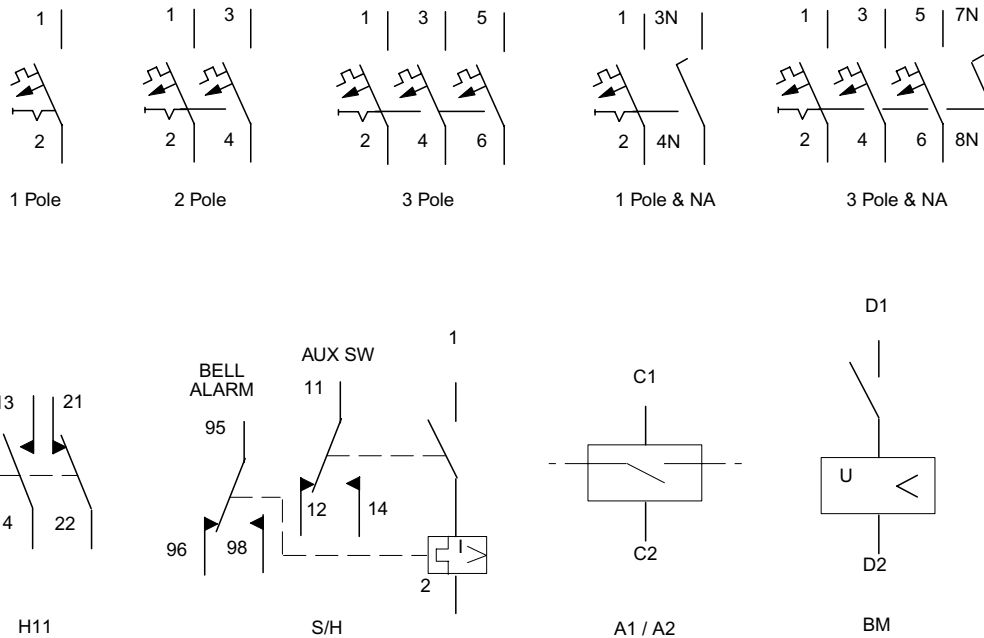

Technical data

Breaker resistance values & wire size comparison



Miniature circuit breaker resistance values

Ampere rating	Milliohms			
	S260-B	S270-K	S280-K	S280-Z
0.2	—	—	33300	—
0.3	—	—	19700	—
0.5	—	6340	5020	10100
0.75	—	—	2400	—
1.0	—	1550	1390	2270
1.6	—	695	612	1100
2	—	460	450	619
3	—	165	147	202
4	—	120	112	149
6	55	52	54.1	104
8	15	38	33.8	53.9
10	13.3	12.6	15.1	17.5
12	13.3	12.6	—	—
16	7.0	7.7	8.1	10.9
20	6.25	6.7	5.27	6.0
25	5.0	4.6	3.97	4.1
32	3.6	3.5	2.65	2.81
40	3.0	2.8	2.44	2.55
50	1.2	1.15	1.15	1.77
63	1.4	0.70	0.70	1.31

Comparison of IEC and AWG wire sizes

mm	AWG (mm)	Amps / UL	Amps / IEC
1.0	—	—	8
—	16 (1.3)	10	—
1.5	—	—	12
—	14 (2.1)	15	—
2.5	—	—	20
—	12 (3.3)	20	—
4	—	—	25
—	10 (5.3)	30	—
6	—	—	32
—	8 (8.4)	50	—
10	—	—	50
—	6 (13.3)	65	—
16	—	—	65
—	4 (21.2)	85	—
25	—	—	85
—	3 (26.7)	100	—
—	2 (33.6)	115	—
35	—	—	115

Ampacities for AWG wire are based on copper cable rated 75° C, except for 16AWG which is based on 60° C wire. Taken from UL508 Table 52.2.

Consult applicable standards for further detail and information.

Approximate dimensions S260, S270, S280, S290

00.00 Inches
00.00 [Millimeters]

S260 & S270

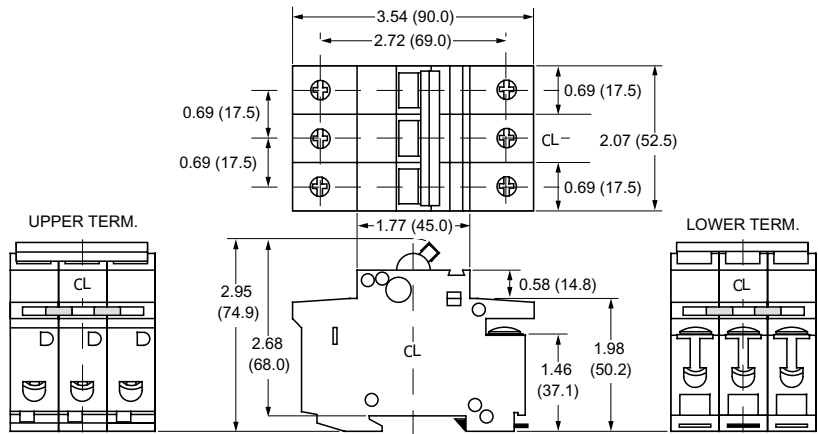

S280

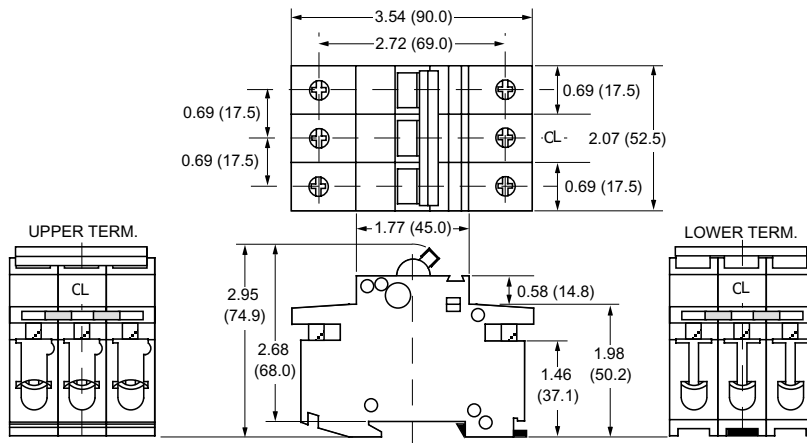

14

S290

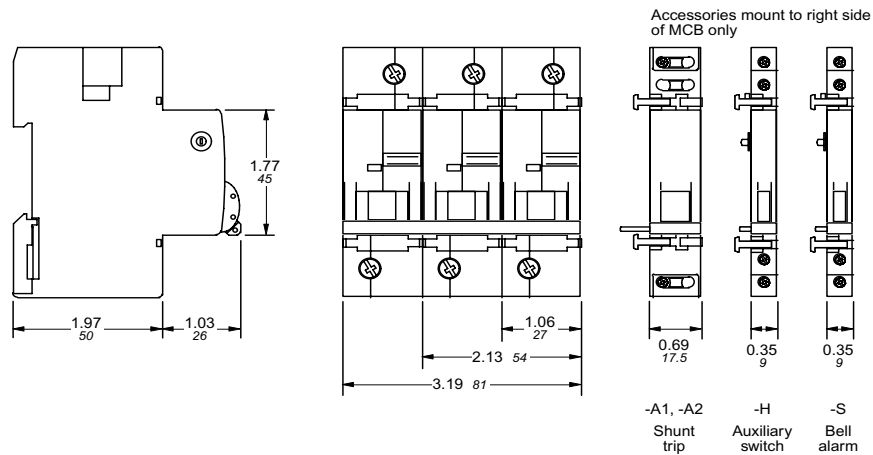

Approximate dimensions Accessories

System
Pro M

00.00 Inches
00.00 [Millimeters]

Accessories

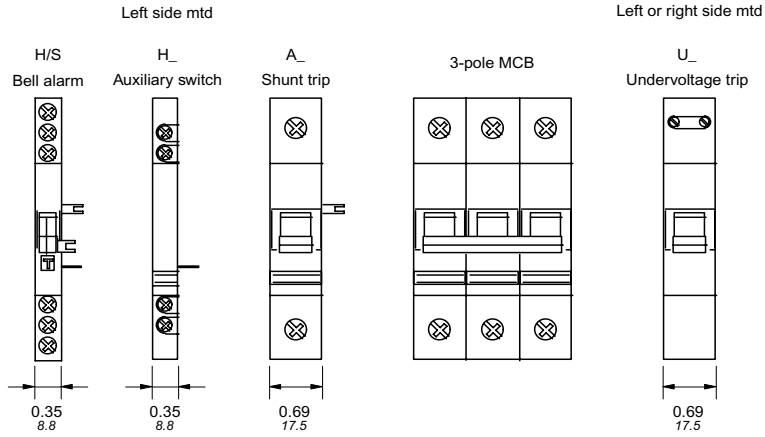

MB-CL Front mounting clip

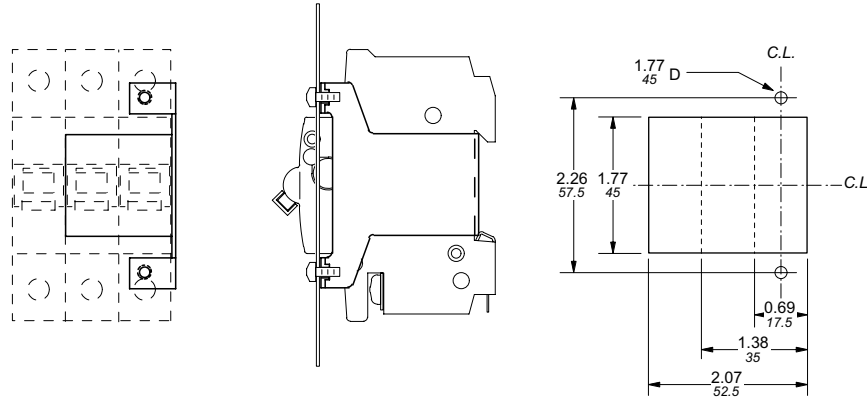

MB-3PD Front mounting bracket

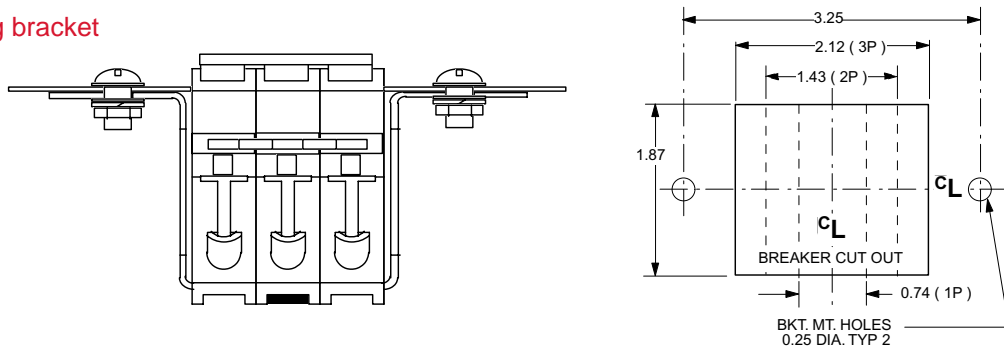

RHS2-M Handle mechanism

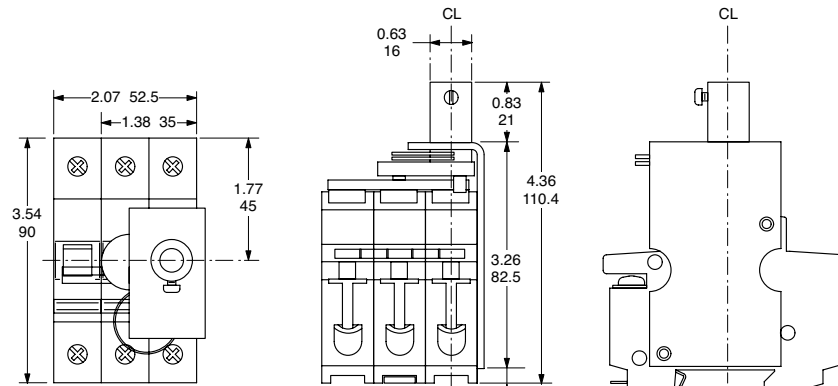



Approximate dimensions Accessories

00.00 Inches
00.00 [Millimeters]

12644

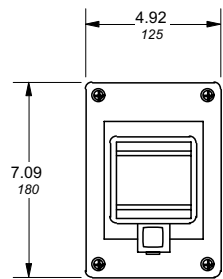
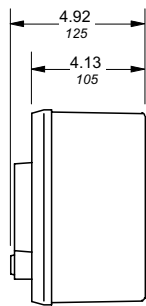

12650

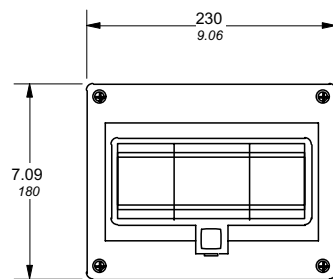
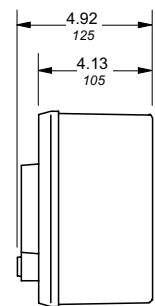

12646

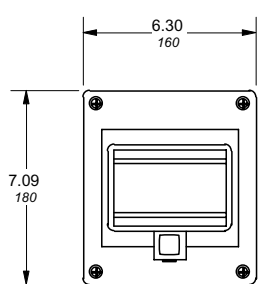
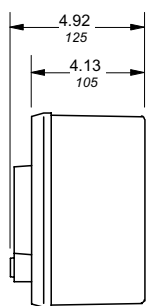

12652

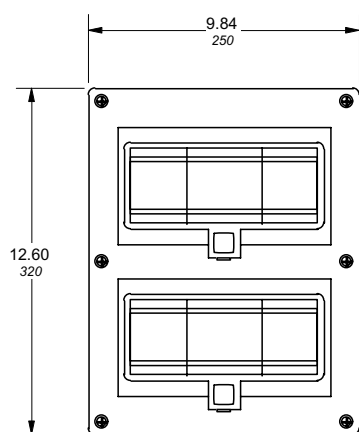
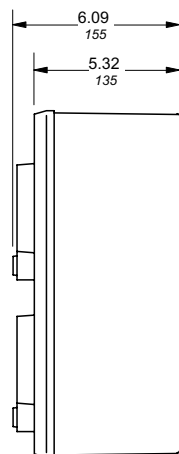

Cross-reference



Older version	Suggested replacement series	Physical comparison	Electrical comparison
S160L	S260B	Same pole spacing	Same trip characteristic as "L"
S160K	S270K	Same pole spacing	Same trip characteristic as "K" S270 is 6kA IC
S210L	S260B	Same pole spacing	Same trip characteristic as "L" S260B is 6kA IC
S210K	S280K	Same pole spacing	Same trip characteristic as "K" S280K is 6kA IC
S210Z	S280Z	Same pole spacing	Same trip characteristic as "Z"
S250L	S260B	Same pole spacing	Same trip characteristic as "L"
S210-UCK	S280UC-K	Same pole spacing	Same trip characteristic as "K"
S210-UCZ	S280UC-Z	Same pole spacing	Same trip characteristic as "Z"
S220-K	S500-K	Different pole spacing	Same trip characteristic as "K"
S230-B	S260-B	Same pole spacing	Same trip characteristic as "B"

Many older styles of ABB miniature circuit breakers have been replaced by new and improved versions. Many of these newer styles can be directly interchanged, both electrically and physically, with the older version. There are also many international styles of ABB circuit breakers which are not normal stock items and may be interchanged with stocked ABB versions.

Note: MCB types S260/270 and S280 can be raised to the same height as older style S210 series MCBs through the use of a height adjuster (SZ-ES68/83; \$ 30 list per 20). The height adjuster snaps onto the DIN rail and raises the height of components 68mm to match that of the S210 series (83mm).



Notes