

TLP558

Isolated Bus Driver
 High Speed Line Receiver
 Microprocessor System Interfaces
 MOS FET Gate Driver
 Transistor Inverter

The TOSHIBA TLP558 consists of a GaAlAs light emitting diode and integrated high gain, high speed photodetector.

This unit is 8-lead DIP package.

The detector has a three state output stage that provides source drive and sink drive, and built-in schmitt trigger. The detector IC has an internal shield that provides a guaranteed common mode transient immunity of 1000V / μ s. TLP558 is inverter logic type. For buffer logic type, TLP555 is in line-up.

- Input current: $I_F=1.6$ mA (max)
- Power supply voltage: $V_{CC}=4.5\sim 20$ V
- Switching speed: $t_{pHL}, t_{pLH}=400$ ns (max)
- Common mode transient immunity: ± 1000 V/ μ s (min)
- Guaranteed performance over temperature: -25 to 85° C
- Isolation voltage: $2500V_{rms}$ (min)
- UL recognized: UL1577, file No. E67349

Truth Table (positive logic)

Input	Enable	Output
H	H	L
L	H	H
H	L	Z
L	L	Z

A 0.1 μ F bypass capacitor must be connected between pins 8 and 5 (see Note 9).

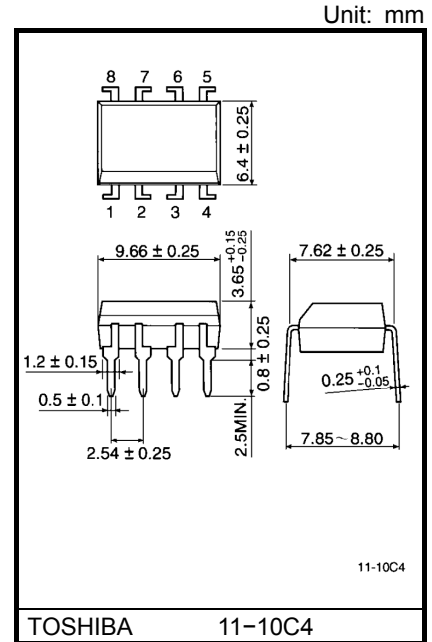

Weight: 0.54 g (typ.)

Pin Configuration (top view)

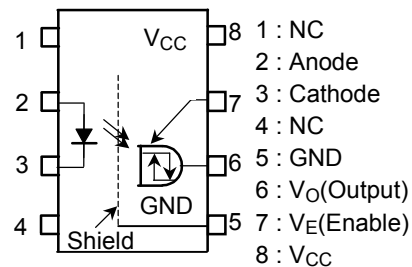

Schematic

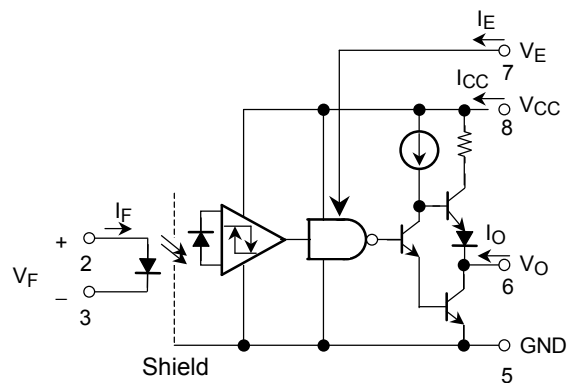

Start of commercial production
 1987/05

Absolute Maximum Ratings

Characteristic		Symbol	Rating	Unit
LED	Forward current	I_F	10	mA
	Peak transient forward current (Note 1)	I_{FPT}	1	A
	Reverse voltage	V_R	5	V
Detector	Output current	I_O	40 / -25	mA
	Peak output current (Note 2)	I_{OP}	80 / -50	mA
	Output voltage	V_O	-0.5~20	V
	Supply voltage	V_{CC}	-0.5~20	V
	Three state enable voltage	V_E	-0.5~20	V
	Output power dissipation (Note 3)	P_O	100	mW
	Total package power dissipation (Note 4)	P_T	200	mW
Operating temperature range		T_{opr}	-40~85	°C
Storage temperature range		T_{stg}	-55~125	°C
Lead solder temperature(10s)**		T_{sol}	260	°C
Isolation voltage (AC, 1 minute, R.H. ≤ 60%, $T_a=25^{\circ}\text{C}$) (Note 5)		BV_S	2500	Vrms

Note: Using continuously under heavy loads (e.g. the application of high temperature/current/voltage and the significant change in temperature, etc.) may cause this product to decrease in the reliability significantly even if the operating conditions (i.e. operating temperature/current/voltage, etc.) are within the absolute maximum ratings.

Please design the appropriate reliability upon reviewing the Toshiba Semiconductor Reliability Handbook ("Handling Precautions"/"Derating Concept and Methods") and individual reliability data (i.e. reliability test report and estimated failure rate, etc).

(Note 1) Pulse width ≤ 1μs, 300pps.

(Note 2) Pulse width ≤ 5μs, duty ratio ≤ 0.025.

(Note 3) Derate 1.8mW / °C above 70°C ambient temperature.

(Note 4) Derate 3.6mW / °C above 70°C ambient temperature.

(Note 5) Device considered a two terminal device: Pins 1, 2, 3 and 4 shorted together, and pins 5, 6, 7 and 8 shorted together.

**1.6mm below seating plane.

Recommended Operating Conditions

Characteristic	Symbol	Min	Typ.	Max	Unit
Input current, on	$I_{F(ON)}$	2*	—	5	mA
Input voltage, off	$V_{F(OFF)}$	0	—	0.8	V
Supply voltage	V_{CC}	4.5	—	20	V
Enable voltage high	V_{EH}	2.0	—	20	V
Enable voltage low	V_{EL}	0	—	0.8	V
Fan out(TTL load)	N	—	—	4	—
Operating temperature	T_{opr}	-25	—	85	°C

Note: Recommended operating conditions are given as a design guideline to obtain expected performance of the device. Additionally, each item is an independent guideline respectively. In developing designs using this product, please confirm specified characteristics shown in this document.

* 2mA condition permits at least 20% CTR degradation guardband.
Initial switching threshold is 1.6mA or less.

Electrical Characteristics (unless otherwise specified, Ta = -25~85°C, VCC = 4.5~20V)

Characteristic	Symbol	Test Condition	Min	Typ.*	Max	Unit	
Input forward voltage	V _F	I _F =5mA, Ta=25°C	—	1.55	1.7	V	
Temperature coefficient of forward voltage	ΔV _F / ΔTa	I _F =5mA	—	-2.0	—	mV / °C	
Input reverse current	I _R	V _R =5V, Ta=25°C	—	—	10	μA	
Input capacitance	C _T	V _F =0, f=1MHz, Ta=25°C	—	45	—	pF	
Output leakage current (V _O > V _{CC})	I _{OHH}	V _F =0, V _{CC} =4.5V	V _O =V _E =5.5V	—	—	100	μA
			V _O =V _E =20V	—	0.01	500	
Logic low output voltage	V _{OL}	I _{OL} =6.4mA, I _F =1.6mA, V _E =2V	—	0.4	0.5	V	
Logic high output voltage	V _{OH}	I _{OH} =-2.6mA, V _F =0.8V, V _E =2V	2.4	3.3	—	V	
Logic low enable current	I _{EL}	V _E =0.4V	—	-0.13	-0.32	mA	
Logic high enable current	I _{EH}	V _E =2.7V	—	—	20	μA	
		V _E =5.5V	—	—	100		
		V _E =20V	—	0.01	250		
Logic low enable voltage	V _{EL}	—	—	—	0.8	V	
Logic high enable voltage	V _{EH}	—	2.0	—	—	V	
Logic low supply current	I _{CCL}	I _F =5mA	V _{CC} =V _E =5.5V	—	4.0	6.0	mA
			V _{CC} =V _E =20V	—	4.6	7.5	
Logic high supply current	I _{CCH}	V _F =0V	V _{CC} =V _E =5.5V	—	4.2	6.0	mA
			V _{CC} =V _E =20V	—	4.7	7.5	
High impedance state output current	I _{OZL}	V _F =0V, V _E =0.8V	V _O =0.4V	—	—	-20	μA
			V _O =2.4V	—	—	20	
	I _{OZH}	I _F =5mA, V _E =0.8V	V _O =5.5V	—	—	100	
			V _O =20V	—	1	500	
Logic low short circuit output current (Note 6)	I _{OSL}	I _F =5mA, V _E =2V	V _O =V _{CC} =5.5V	25	55	—	mA
			V _O =V _{CC} =20V	40	80	—	
Logic high short circuit output current (Note 6)	I _{OSH}	V _F =0V, V _O =GND, V _E =2V	V _{CC} =5.5V	-10	-25	—	mA
			V _{CC} =20V	-25	-60	—	
Input current logic low output	I _{FL}	V _E =2V, I _O =6.4mA, V _O < 0.4V	—	0.4	1.6	mA	
Input voltage logic high output	V _{FH}	V _E =2V, I _O =-2.6mA, V _O > 2.4V	0.8	—	—	V	
Input current hysteresis	I _{HYS}	V _{CC} =V _E =5V	—	0.05	—	mA	
Resistance (input-output)	R _S	V _S =500V, R.H. ≤60%, Ta=25°C (Note 5)	5×10 ¹⁰	10 ¹⁴	—	Ω	
Capacitance(input-output)	C _S	V _S =0, f=1MHz, Ta=25°C (Note 5)	—	1.0	—	pF	

*All typical values are at Ta=25°C, VCC=5V, I_{F(ON)}=3mA unless otherwise specified.

(Note 6) Duration of output short circuit time should not exceed 10ms.

Switching Characteristics (unless otherwise specified, $V_{CC} = 4.5\sim 20V$, $T_a = 25^\circ C$)

Characteristic	Symbol	Test Circuit	Test Condition	Min	Typ.*	Max	Unit
Propagation delay time to logic high output (Note 7)	t_{pLH}	1	$I_F=3 \rightarrow 0mA$	—	250	400	ns
Propagation delay time to logic low output (Note 7)	t_{pHL}		$I_F=0 \rightarrow 3mA$	—	270	400	ns
Output rise time (10–90%)	t_r		$I_F=3 \rightarrow 0mA, V_{CC}=5V$	—	35	75	ns
Output fall time (90–10%)	t_f		$I_F=0 \rightarrow 3mA, V_{CC}=5V$	—	20	75	ns
Output enable time to logic high	t_{pZH}	2	$V_E=0 \rightarrow 3V$	—	—	—	ns
Output enable time to logic low	t_{pZL}		$V_E=0 \rightarrow 3V$	—	—	—	ns
Output disable time from logic high	t_{pHZ}		$V_E=3 \rightarrow 0V$	—	—	—	ns
Output disable time from logic low	t_{pLZ}		$V_E=3 \rightarrow 0V$	—	—	—	ns
Common mode transient immunity at logic high output (Note 8)	C_{MH}	3	$I_F=0mA, V_{CM}=50V$ $V_O(\text{Min})=2V$	1000	—	—	V / μs
Common mode transient immunity at logic low output (Note 8)	C_{ML}		$I_F=1.6mA, V_{CM}=50V$ $V_O(\text{Max})=0.8V$	–1000	—	—	V / μs

* All typical values are at $T_a=25^\circ C$, $V_{CC}=5V$

(Note 7) The t_{pLH} propagation delay is measured from the 50% point on the trailing edge of the input pulse to the 1.3V point on the leading edge of the output pulse. The t_{pHL} propagation delay is measured from the 50% point on the leading edge of the input pulse to the 1.3V point on the trailing edge of the output pulse.

(Note 8) C_{ML} is the maximum rate of fall of the common mode voltage that can be sustained with the output voltage in the logic low state ($V_O < 0.8V$).

C_{MH} is the maximum rate of rise of the common mode voltage that can be sustained with the output voltage in the logic state ($V_O > 2.0V$).

(Note 9) A ceramic capacitor (0.1 μF) should be connected from pin 8 to pin 5 to stabilize the operation of the high gain linear amplifier. Failure to provide the bypassing may impair the switching property. The total lead length between capacitor and coupler should not exceed 1cm.

Test Circuit 1: t_{pLH} , t_{pHL} , t_r and t_f

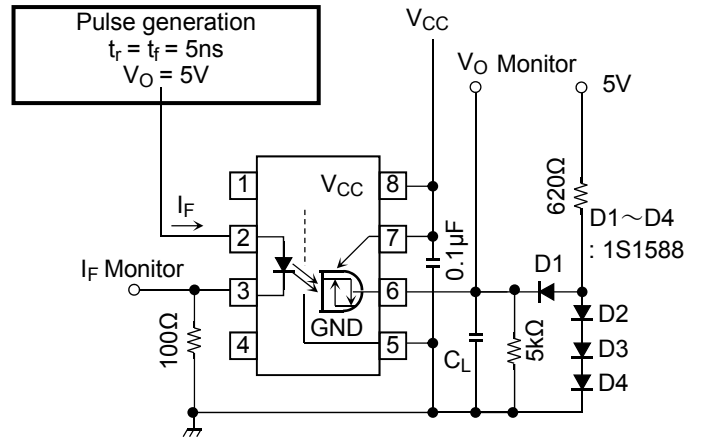
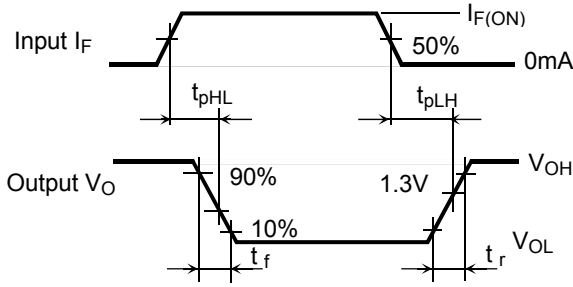

C_L is approximately 15pF which includes probe and stray wiring capacitance.

Test Circuit 2: t_{pHZ} , t_{pZH} , t_{pLZ} and t_{pZL}

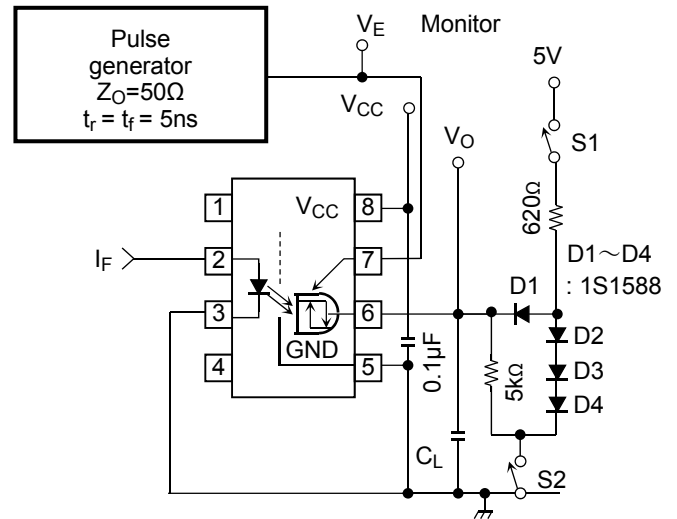
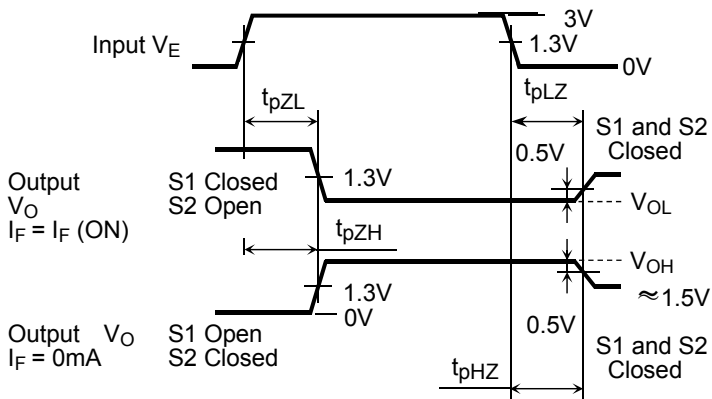

C_L is approximately 15pF which includes probe and stray wiring capacitance.

Test Circuit 3: Common Mode Transient Immunity

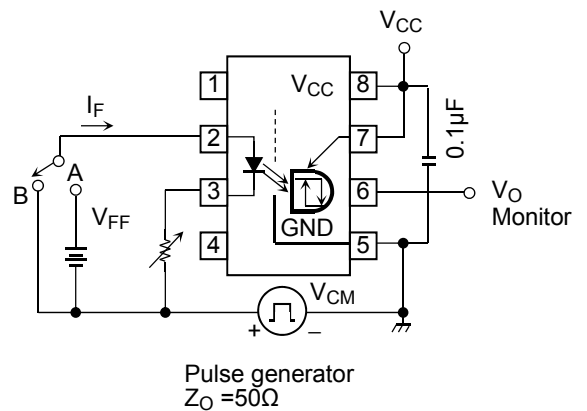
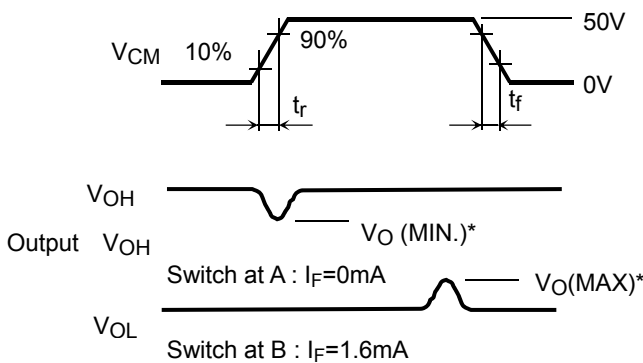

* Note 8

$$CM_H = \frac{45(V)}{t_f(\mu s)}, CM_L = \frac{45(V)}{t_r(\mu s)}$$

RESTRICTIONS ON PRODUCT USE

- Toshiba Corporation, and its subsidiaries and affiliates (collectively "TOSHIBA"), reserve the right to make changes to the information in this document, and related hardware, software and systems (collectively "Product") without notice.
- This document and any information herein may not be reproduced without prior written permission from TOSHIBA. Even with TOSHIBA's written permission, reproduction is permissible only if reproduction is without alteration/omission.
- Though TOSHIBA works continually to improve Product's quality and reliability, Product can malfunction or fail. Customers are responsible for complying with safety standards and for providing adequate designs and safeguards for their hardware, software and systems which minimize risk and avoid situations in which a malfunction or failure of Product could cause loss of human life, bodily injury or damage to property, including data loss or corruption. Before customers use the Product, create designs including the Product, or incorporate the Product into their own applications, customers must also refer to and comply with (a) the latest versions of all relevant TOSHIBA information, including without limitation, this document, the specifications, the data sheets and application notes for Product and the precautions and conditions set forth in the "TOSHIBA Semiconductor Reliability Handbook" and (b) the instructions for the application with which the Product will be used with or for. Customers are solely responsible for all aspects of their own product design or applications, including but not limited to (a) determining the appropriateness of the use of this Product in such design or applications; (b) evaluating and determining the applicability of any information contained in this document, or in charts, diagrams, programs, algorithms, sample application circuits, or any other referenced documents; and (c) validating all operating parameters for such designs and applications. **TOSHIBA ASSUMES NO LIABILITY FOR CUSTOMERS' PRODUCT DESIGN OR APPLICATIONS.**
- **PRODUCT IS NEITHER INTENDED NOR WARRANTED FOR USE IN EQUIPMENTS OR SYSTEMS THAT REQUIRE EXTRAORDINARILY HIGH LEVELS OF QUALITY AND/OR RELIABILITY, AND/OR A MALFUNCTION OR FAILURE OF WHICH MAY CAUSE LOSS OF HUMAN LIFE, BODILY INJURY, SERIOUS PROPERTY DAMAGE AND/OR SERIOUS PUBLIC IMPACT ("UNINTENDED USE").** Except for specific applications as expressly stated in this document, Unintended Use includes, without limitation, equipment used in nuclear facilities, equipment used in the aerospace industry, medical equipment, equipment used for automobiles, trains, ships and other transportation, traffic signaling equipment, equipment used to control combustions or explosions, safety devices, elevators and escalators, devices related to electric power, and equipment used in finance-related fields. **IF YOU USE PRODUCT FOR UNINTENDED USE, TOSHIBA ASSUMES NO LIABILITY FOR PRODUCT.** For details, please contact your TOSHIBA sales representative.
- Do not disassemble, analyze, reverse-engineer, alter, modify, translate or copy Product, whether in whole or in part.
- Product shall not be used for or incorporated into any products or systems whose manufacture, use, or sale is prohibited under any applicable laws or regulations.
- The information contained herein is presented only as guidance for Product use. No responsibility is assumed by TOSHIBA for any infringement of patents or any other intellectual property rights of third parties that may result from the use of Product. No license to any intellectual property right is granted by this document, whether express or implied, by estoppel or otherwise.
- **ABSENT A WRITTEN SIGNED AGREEMENT, EXCEPT AS PROVIDED IN THE RELEVANT TERMS AND CONDITIONS OF SALE FOR PRODUCT, AND TO THE MAXIMUM EXTENT ALLOWABLE BY LAW, TOSHIBA (1) ASSUMES NO LIABILITY WHATSOEVER, INCLUDING WITHOUT LIMITATION, INDIRECT, CONSEQUENTIAL, SPECIAL, OR INCIDENTAL DAMAGES OR LOSS, INCLUDING WITHOUT LIMITATION, LOSS OF PROFITS, LOSS OF OPPORTUNITIES, BUSINESS INTERRUPTION AND LOSS OF DATA, AND (2) DISCLAIMS ANY AND ALL EXPRESS OR IMPLIED WARRANTIES AND CONDITIONS RELATED TO SALE, USE OF PRODUCT, OR INFORMATION, INCLUDING WARRANTIES OR CONDITIONS OF MERCHANTABILITY, FITNESS FOR A PARTICULAR PURPOSE, ACCURACY OF INFORMATION, OR NONINFRINGEMENT.**
- GaAs (Gallium Arsenide) is used in Product. GaAs is harmful to humans if consumed or absorbed, whether in the form of dust or vapor. Handle with care and do not break, cut, crush, grind, dissolve chemically or otherwise expose GaAs in Product.
- Do not use or otherwise make available Product or related software or technology for any military purposes, including without limitation, for the design, development, use, stockpiling or manufacturing of nuclear, chemical, or biological weapons or missile technology products (mass destruction weapons). Product and related software and technology may be controlled under the applicable export laws and regulations including, without limitation, the Japanese Foreign Exchange and Foreign Trade Law and the U.S. Export Administration Regulations. Export and re-export of Product or related software or technology are strictly prohibited except in compliance with all applicable export laws and regulations.
- Please contact your TOSHIBA sales representative for details as to environmental matters such as the RoHS compatibility of Product. Please use Product in compliance with all applicable laws and regulations that regulate the inclusion or use of controlled substances, including without limitation, the EU RoHS Directive. **TOSHIBA ASSUMES NO LIABILITY FOR DAMAGES OR LOSSES OCCURRING AS A RESULT OF NONCOMPLIANCE WITH APPLICABLE LAWS AND REGULATIONS.**