

**Ordering number C12285\_ANGIE-S**

Family	Angie	FWHM	15 degrees
Type	Lens array	Efficiency	93 %
LED	XP-G	cd/lm	8.020
Color	Clear	Gerber File	Available
Diameter	34 mm		
Height	10.7 mm		
Style	Round		
Optic Material	PMMA		
Holder Material	-		
Fastening	Pin, glue		
Status	Ready		

**Ordering number C12286\_ANGIE-M**

Family	Angie	FWHM	24 degrees
Type	Lens array	Efficiency	88 %
LED	XP-G	cd/lm	4.620
Color	Clear	Gerber File	Available
Diameter	34 mm		
Height	10.7 mm		
Style	Round		
Optic Material	PMMA		
Holder Material	-		
Fastening	Pin, glue		
Status	Ready		

**Ordering number C12287\_ANGIE-M2**

Family	Angie	FWHM	31 degrees
Type	Lens array	Efficiency	89 %
LED	XP-G	cd/lm	2.370
Color	Clear	Gerber File	Available
Diameter	34 mm		
Height	10.7 mm		
Style	Round		
Optic Material	PMMA		
Holder Material	-		
Fastening	Pin, glue		
Status	Ready		

**Ordering number C12288\_ANGIE-W**

Family	Angie	FWHM	37 degrees
Type	Lens array	Efficiency	86 %
LED	XP-G	cd/lm	1.510
Color	Clear	Gerber File	Available
Diameter	34 mm		
Height	10.7 mm		
Style	Round		
Optic Material	PMMA		
Holder Material	-		
Fastening	Pin, glue		
Status	Ready		



**PRODUCT DATASHEET**  
**Angie series**  
last update 18/9/2012

**NOTE: The typical divergence will be changed by different color, chip size and chip position tolerance. The typical total divergence is the full angle measured where the luminous intensity is half of the peak value.**



## PRODUCT DATASHEET

### Angie series

last update 18/9/2012

#### GENERAL INFORMATION

- Product series especially designed & optimized for XP-G series of LEDs.
- Special care taken to make light distribution as uniform as possible.
- Lens material optical grade PMMA with high UV and temperature resistance. Allows use of high current and temperature conditions.

Please find more information about used material from below:

[http://ledil.fi/sites/default/files/Documents/Technical/Material/PMMA%20N%20UL94\\_Yellow%20Card.pdf](http://ledil.fi/sites/default/files/Documents/Technical/Material/PMMA%20N%20UL94_Yellow%20Card.pdf)

<http://ledil.fi/sites/default/files/Documents/Technical/Material/PMMA%20N%20PLEXIGLAS-Datasheet.pdf>

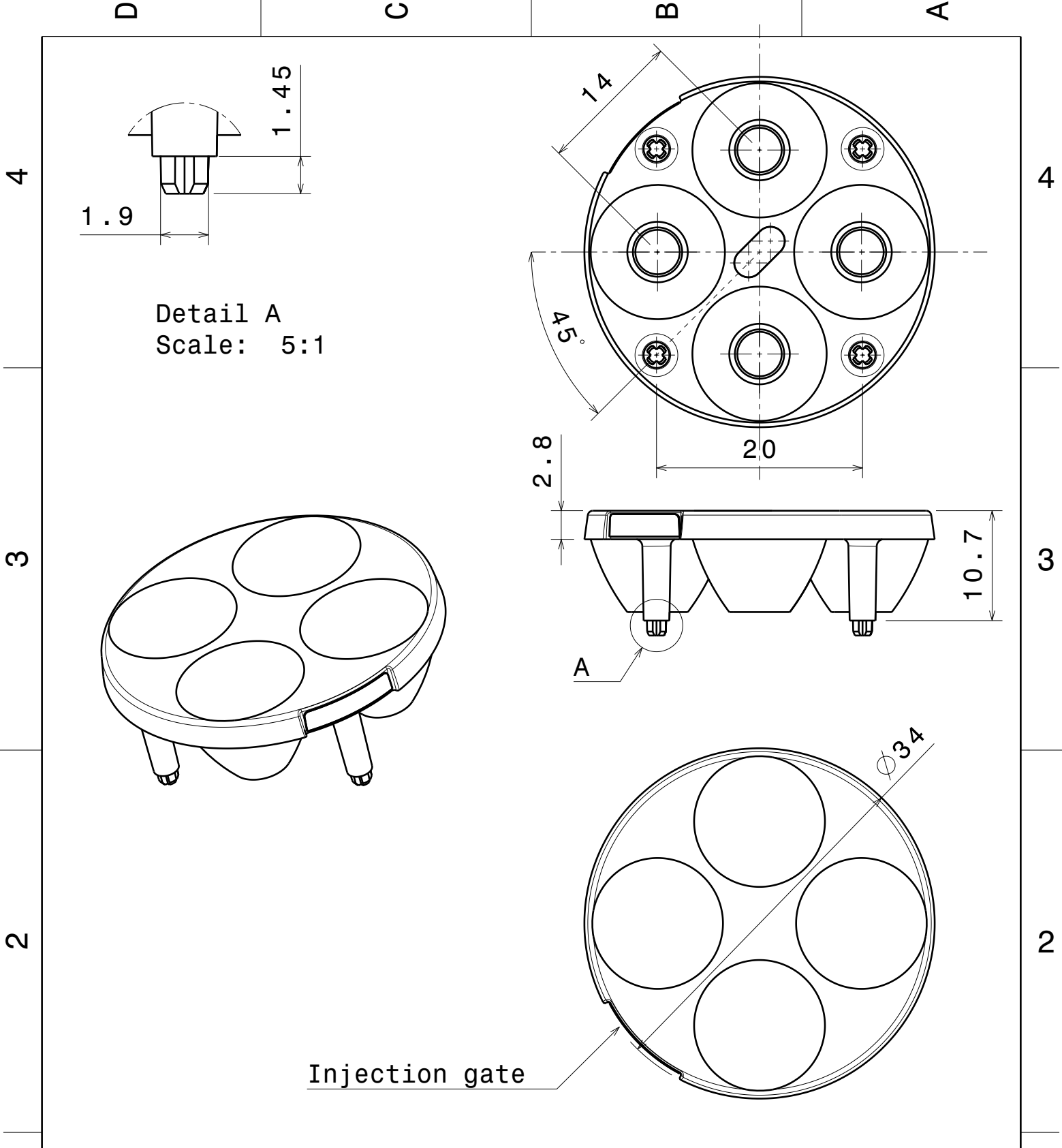

This drawing is our property.  
It can't be reproduced  
or communicated without  
our written agreement.



Ledil Oy  
Salorankatu 10  
FIN-24240 SALO  
Finland

DRAWING TITLE

Angie-series mechanical drawing

DRAWN BY pl	DATE 22.09.2011
CHECKED BY --	DATE --
DESIGNED BY pl	DATE 02.09.2011

SIZE A4	DRAWING NUMBER ----	REV -
SCALE 2:1	WEIGHT (g)	SHEET 1/1

D

A