

# Digital Timer H5AN

CSM\_H5AN\_DS\_E\_4\_1

## DIN-sized (72 x 72 mm) Quartz Timer with Multiple Functions

- Wide time range from 1/100 seconds to 9999 hrs.
- Built-in power supply incorporated in timer enables direct connection of sensors and other components.
- Draw-out construction allows maintenance without disconnecting the wiring.
- Power supply freely selectable within a range of 100 to 240 VAC; a DC-operated version is also available.
- Control outputs of both contact type and transistor type simultaneously available.
- Seven operating modes (N, F, C, R, K, P, and Q) are available.



For the most recent information on models that have been certified for safety standards, refer to your OMRON website.

## Ordering Information

Operation system	Resetting system	No. of digits	Backup power supply function for memory protection	Model
Time-limit operation, integrating operation	Power-OFF resetting (excluding -M), external resetting, manual resetting, automatic resetting	4 digits (switch-selectable): 0.01 to 99.99 s, 0.1 to 999.9 s, 1 to 9999 s, 0.1 to 999.9 min, 0.1 to 999.9 hrs, 1 to 9999 hrs, 1 s to 99 min 59 s, 1 min to 99 hrs 59 min	Not provided	H5AN-4D
			Can be enabled and disabled with a DIP switch.	H5AN-4DM

- Note:**
1. Specify both the model number and supply voltage when ordering.
  2. The Timer is supplied with two mounting fixtures.

# Specifications

## ■ Ratings

Item	H5AN-4D/H5AN-4DM
Rated supply voltage	H5AN-4D: 100 to 240 VAC (50/60 Hz), 12 to 24, 48, or 100 VDC (permissible ripple: 20% max.) H5AN-4DM: 100 to 240 VAC (50/60 Hz) 12 to 24 VDC (permissible ripple: 20% max.)
Operating voltage range	85% to 110% of rated supply voltage
Power consumption	Approx. 10 VA (at 240 VAC), approx. 5 W (at 24 VDC)
Resetting system and gate input	Reset by power-OFF: min. power OFF time: 0.5 s (see note) External reset or gate (common to contact and transistor inputs): min. reset input signal width: 0.02 s
One-shot output time	0.1 to 1 s (adjustable)
Control outputs	Contact output: SPDT, 3 A at 250 VAC, resistive load ( $\cos\phi = 1$ ) Transistor output: Open collector, 100 mA max. at 30 VDC max.
Power supply for externally connected components	12 VDC $\pm$ 10%, 80 mA (permissible ripple: 5% max.)
Case color	Light gray (Munsell 5Y7/1)

**Note:** This does not apply to the models ending with -M when memory backup is enabled.

## ■ Characteristics

<b>Accuracy of operating time</b>	$\pm 0.01\% \pm 0.05$ s max. (power OFF start), $\pm 0.005\% \pm 0.03$ s max. (reset start) (see note 1)
<b>Setting error</b>	
<b>Influence of voltage</b>	
<b>Influence of temperature</b>	
<b>Insulation resistance</b>	100 M $\Omega$ min. (at 500 VDC) (between current-carrying terminal and exposed non-current carrying metal parts, between non-continuous contacts)
<b>Dielectric strength</b>	2,000 VAC, 50/60 Hz for 1 min (between current-carrying and non-current-carrying metal parts) 750 VAC, 50/60 Hz for 1 min (between non-continuous contacts)
<b>Impulse withstand voltage</b>	6 kV (between power supply terminal) 6 kV (between current-carrying terminal and exposed non-current carrying metal parts)
<b>Vibration resistance</b>	Destruction: 10 to 55 Hz with 0.75-mm double amplitude Malfunction: 10 to 55 Hz with 0.5-mm double amplitude
<b>Shock resistance</b>	Destruction: 300 m/s <sup>2</sup> (approx. 30G) Malfunction: 100 m/s <sup>2</sup> (approx. 10G)
<b>Ambient temperature</b>	Operating: -10°C to 55°C Storage: -25°C to 65°C
<b>Ambient humidity</b>	Operating: 35% to 85%
<b>Life expectancy</b>	Mechanical: 10,000,000 operations min. (under no load at 1,800 operations/h) Electrical: 100,000 operations min. (3 A at 250 VAC, resistive load)
<b>Memory backup storage method (see note 2)</b>	Non-volatile memory (Number of writes: 1 million times, Data retention: 10 years)
<b>Approved standards</b>	UL (File No. E41515), CSA (File No. LR22310)
<b>Weight</b>	Approx. 360 g

**Note:** 1. This value denotes the average of the repeat accuracy, setting error, and variations due to voltage and temperature changes. It includes the rise time of the power supply, and the operating time of the internal and output circuits.

2. This applies only to the models ending with -M.

# Engineering Data

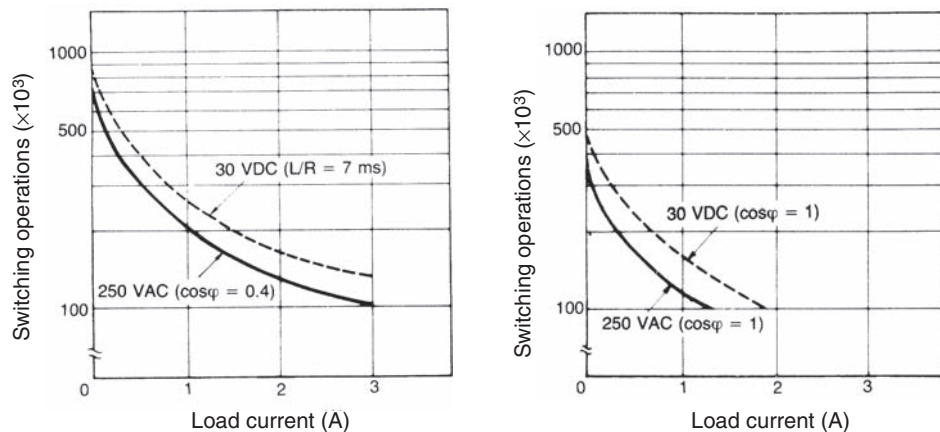

Reference: A maximum current of 0.15 A can be switched at 125 VDC ( $\cos\phi = 1$ ). Maximum current of 0.1 A can be switched if L/R is 7 ms. In both cases, a life of 100,000 operations can be expected. The minimum applicable load is 10 mA at 5 VDC (P reference value).

# Nomenclature

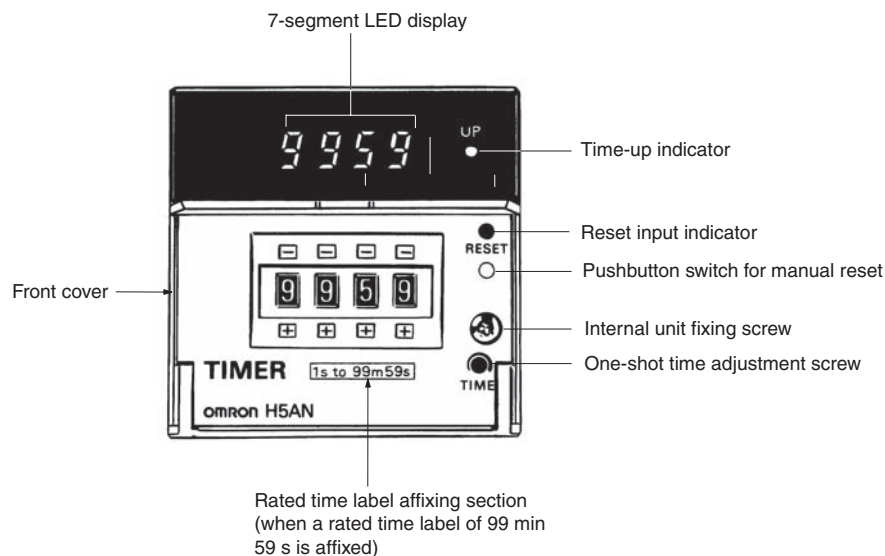

# Operation

## ■ Timing Chart

### Digital Display

#### UP Display

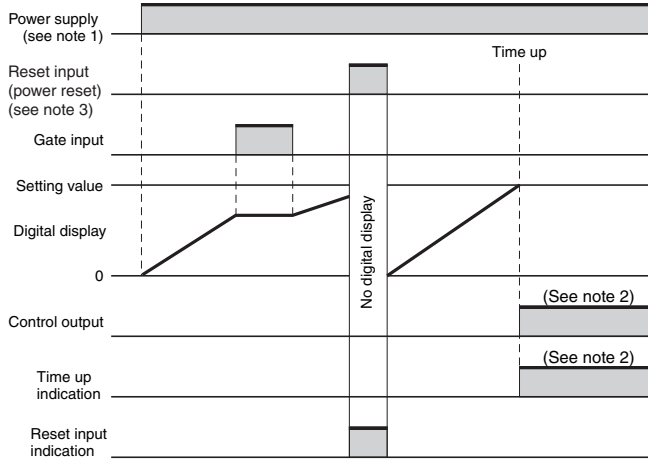

#### DOWN Display

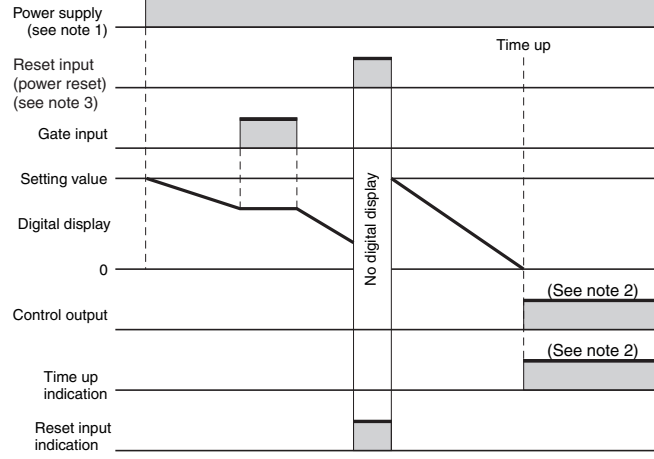

- Note:**
- For models with memory backup (H5AN-□M), you cannot perform a power-OFF reset, so use the reset input.
  - After the set time has elapsed, operation continues according to the mode (N, F, C, R, K, P, or Q).
  - When memory backup is enabled for the H5AN-4DM, you cannot perform a power-OFF reset, so use the reset input.

### Operation Mode

(The control output and digital display when the set time is up differ in each of the operation modes available.)



Mode	UP display	DOWN display	Operation after the set time is up
<b>N</b>			The control output and digital display are held until a reset input is applied.
<b>F</b>			In UP mode, the digital display continues to increment up to "9999" even after reaching the set value and then returns to all zeroes. In DOWN mode, the digital display continues to up 9999, and then decrements "9998, 9997, ...," after reaching all zeroes. The control output is held until a reset input is applied.
<b>C</b>			The digital display returns to the initial setting once the set time has elapsed and the timer restarts the timing operation. When the set time has elapsed, the output signal is generated during the one-shot time. The timer repeats this cycle.
<b>R</b>			The digital display returns to the initial setting after the one-shot time and the timer restarts the timing operation. When the set time has elapsed, the output signal is generated during the one-shot time. The timer repeats this cycle.

Mode	UP display	DOWN display	Operation after the set time is up
<b>K</b>			<p>In UP mode, the digital display continues to increment up to "9999", even after reaching the set value and then returns to all zeroes. In DOWN mode, the digital display continues up to 9999, and the decrements "9998, 9997, ..." after reaching all zeroes. The timer restarts the timing operation when the incrementing or decrementing value reaches the set value. The output is generated during the one-shot time. The timer repeats this cycle.</p>
<b>P</b>			<p>For the digital display, the value at the up is held during the one-shot time; however, the timing operation of the timer returns to the initial setting when the set time has elapsed and the timer restarts the timing operation. When the set time has elapsed, the output signal is generated during the one-shot time. The timer repeats this cycle.</p>
<b>Q</b>			<p>In UP mode, the digital display continues to increment after reaching the set value during the one-shot time. In DOWN mode, the digital display continues to 9999 and then decrements "9998, 9997, ..." after reaching all zeros during the one-shot time. However, in both UP and DOWN modes, the digital display returns to the initial setting after the one-shot time and the timer restarts the timing operation. When the set time has elapsed, the output signal is generated during the one-shot time. The timer repeats this cycle.</p>

- Note:**
- When a rated time of 99 min 59 s or 99 h 59 min is selected, the overflow values of the digital display when using the DOWN (countdown) function will be indicated as 9959, 9958, 9957, ... in modes F, K, and Q.
  - In this timing chart, the number of step advances during the one-shot time varies in accordance with the selected rated time and duration of the one-shot time.
  - In C and P modes, set time value  $n$  should be sufficiently longer than the one-shot time  $t$ .
  - In C mode, the internal count circuit is reset when the set time has elapsed. The numeric time-up value will therefore not be displayed.
  - When using the timer in operation modes other than N and F modes (i.e., C, R, K, P, and Q), the control output is available for the one-shot time only. For this reason, adjust the one-shot time by rotating the one-shot time adjustment screw on the front panel (variable within a range of 0.1 to 1 s).

## ■ Programming of Specifications

The built-in specification selector switches are used to program the UP/DOWN display, rated time, operation mode, and output level of the transistor output when the set time has elapsed, and the memory backup selector switch is built-in as well. Set these switches for programming the desired functional specifications by referring to *Positions and Functions of Specification Selector Switches*.

If you change the settings on the specification selector switches, you must reset the Timer to enable the new settings. (An automatic reset will not enable the new settings.) If you do not reset the Timer, operation will continue with the previous settings.

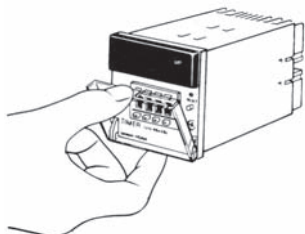

Open the front cover.

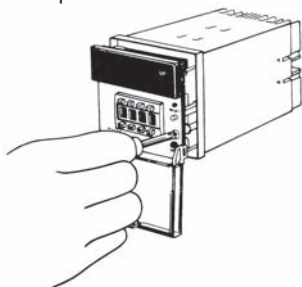

The internal unit comes out by loosening the internal unit fixing screw.

## Positions and Functions of Specification Selector Switches

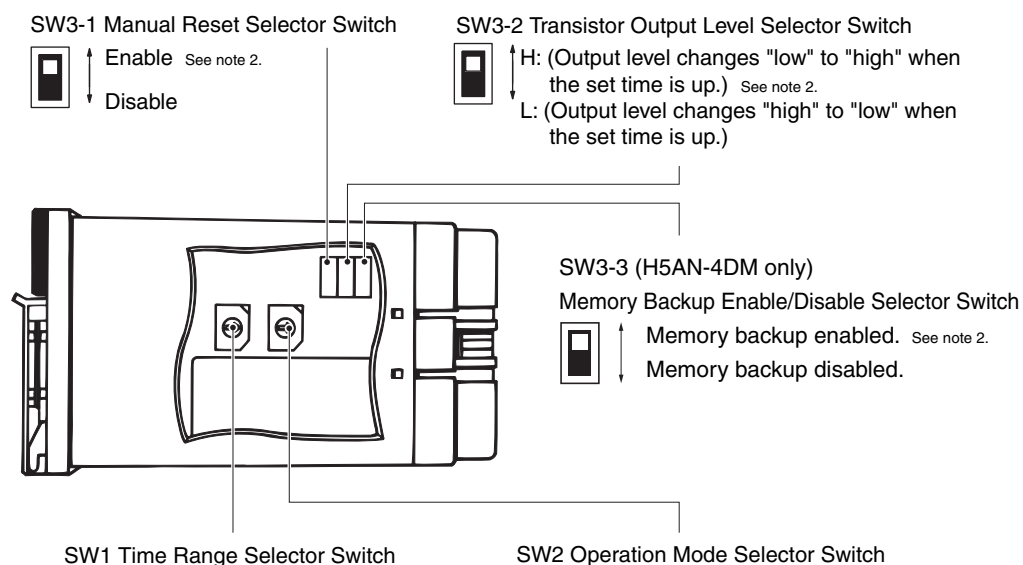

### SW1

Switch position	Rated time	Setting range
0	99.99 s	0.01 to 99.99 s
1	999.9 s	0.1 to 999.9 s
2	9999 s	1 to 9999 s
3	99 min 59 s	1 s to 99 min 59 s
4	999.9 min	0.1 to 999.9 min
5	99 hrs 59 min	1 min to 99 hrs 59 min
6	999.9 hrs	0.1 to 999.9 hrs
7	9999 hrs	1 to 9999 hrs
8	99.99 s	Same as switch position "0"
9	999.9 s	Same as switch position "1"

**Note: 1.** Select the appropriate label, from the rated time labels supplied as accessories, and affix it on the proper position on the front panel.

**2.** The figure shows the factory settings of the specification selector switches.

### SW2

Switch position	Operating mode	Display mode
0	N	DOWN display
1	F	
2	C	
3	R	
4	K	
5	P	
6	Q	
7	N (see note 1)	UP display
8	N	
9	F	
A	C	
B	R	
C	K	
D	P	<b>Note:</b> Same as switch position "8"
E	Q	
F	N (see note 2)	

# Dimensions

**Note:** All units are in millimeters unless otherwise indicated.

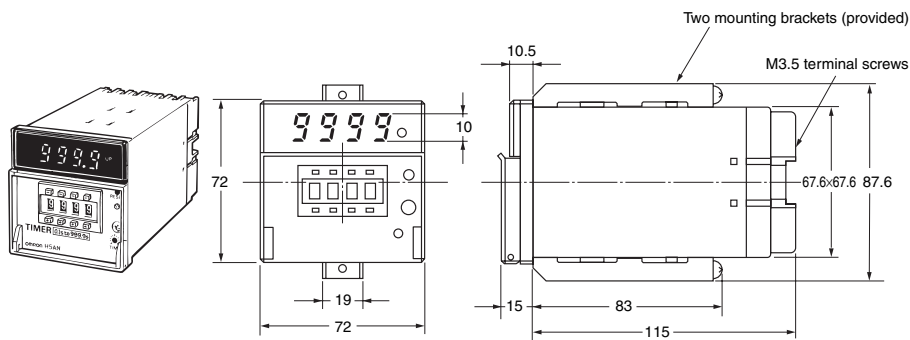

\* Use model number Y92H-5 to order additional brackets.

- Note:**
1. The panel cutouts for the H5AN are as shown (according to DIN43700).
  2. The recommended mounting panel thickness is from 1 to 5 mm.
  3. Use the mounting bracket (sold together) to mount the digital timer.

## Panel Cutouts (Panel cutout conforms to DIN 43700)

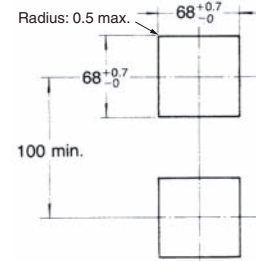

(When N units are flush-mounted horizontally.)

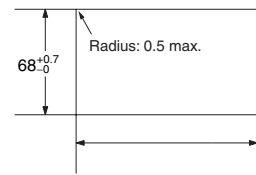

$(n-1) \times 72 + 70$  min.  
(including a tolerance of 2 mm)

## Mounting

Mounting brackets are included with the H5AN. Use these brackets to mount the H5AN securely so that there is no play.

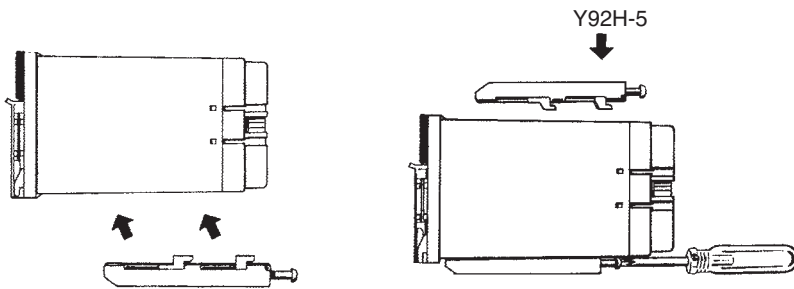

Turn the screws on the mounting brackets counterclockwise to loosen them sufficiently. Attach the bottom mounting bracket first.

After attaching the mounting brackets, turn the screws clockwise to tighten them sufficiently. When the screws are completely tightened, you will hear the threads disengage.

# Installation

## Block Diagram

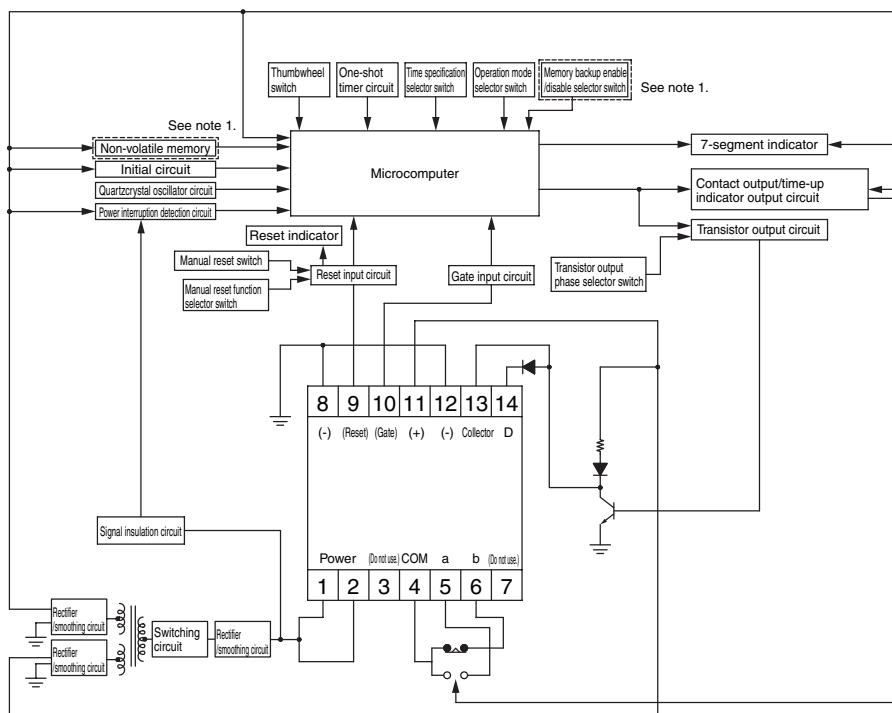

- Note:** 1. Only the H5AN-4DM has the A portion.  
 2. Polarity when using DC power supply: Terminal 1: Negative, Terminal 2: Positive

## Terminal Arrangement

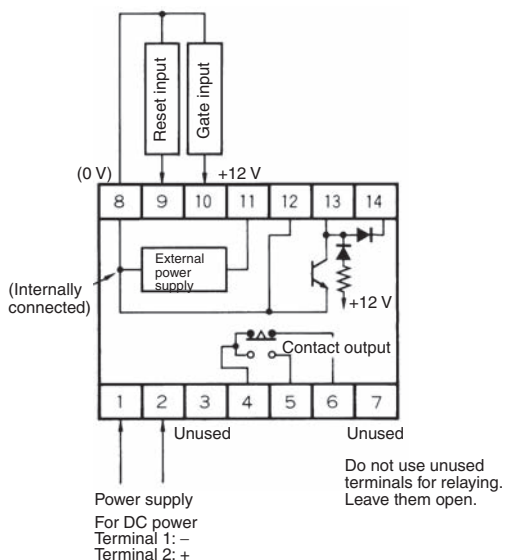

- Note:** Specifications for 12- to 24-VDC, and 100-VDC models are listed separately in this datasheet.

## ■ Connections

### Power Supply Connection

Connect the required supply voltage to terminals 1 and 2.

### Load Connection

Terminals 4, 5, and 6 are for contact output while terminals 12 and 13 are for transistor output. (Terminal 14 is connected to absorb the surge if an inductive load is connected.)

The control outputs of both contact type and transistor type are simultaneously available.

#### Load Operation

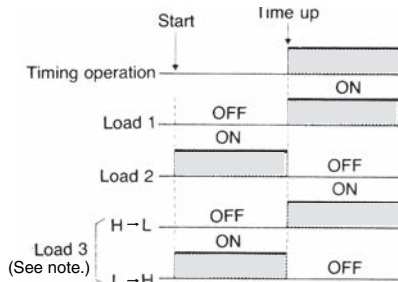

Note: Output transistor ON: Low (0 V)  
Output transistor OFF: High (12 V)

#### When a Load Operates with Contact Output

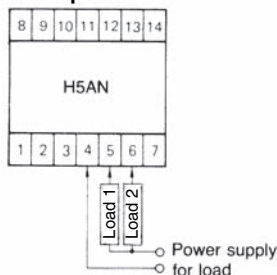

#### When a Load Operates with Transistor Output

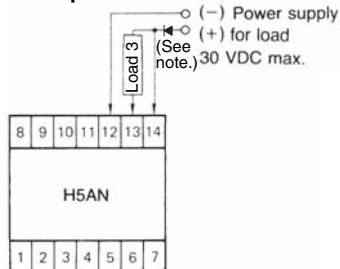

Note: Connect a diode when using a Power Supply of 12 V or less.

### Connection of Reset and Gate Inputs

For reset input, connect a contact or an open collector type transistor between terminals 8 and 9. The timer resets when contact is made or when the transistor is ON. For gate inputs, connect a contact or an open collector type transistor between terminals 8 and 10. The timer stops when contact is made or when the transistor is ON.

Use a contact of high contact reliability, or an open collector type transistor with characteristics:  $V_{CE0} = 20 \text{ V min.}$ ,  $V_{CE(S)}$  (residual voltage) = 3 V max.,  $I_C = 50 \text{ mA min.}$  and  $I_{CBO}$  (leakage current) = 0.5  $\mu\text{A max.}$  Use of a gate input contact with minimum contact bounce (chatter) is a must, since the contact bounce time will cause an error in timer operating time.

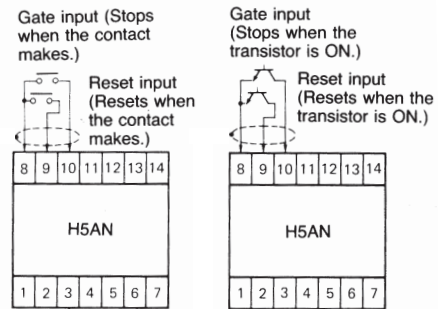

When connecting a transistor circuit not of the open collector type to the gate or reset inputs as shown below, the voltage of the transistor circuit (+V) should be 13 to 30 V, and the  $V_{CE(S)}$  of the transistor should be less than 3 V (the current that flows from either terminal 9 or 10 is approximately 10 mA). Moreover, it is essential that the circuit be ON for gate or reset input, and OFF when there is no input.

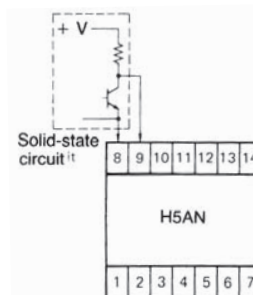

### Connection of a Power Supply for Externally Connected Components

The H5AN has a built-in power supply for externally connected components such as sensors for gate or reset input, or loads connected to the transistor control output (12 VDC, 80 mA). Power can be applied to the sensors and loads simultaneously.

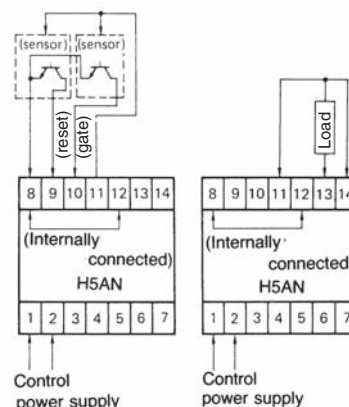

## Simultaneous Input to a Number of H5AN Timers with the Same Contact or the Same Open Collector Transistor

A reset or gate input may be applied to two or more units of H5AN with only one contact or transistor as shown below. In this case, caution is required as a large current flows into the transistor. (The current that flows from H5AN is approximately 10 mA per unit.)

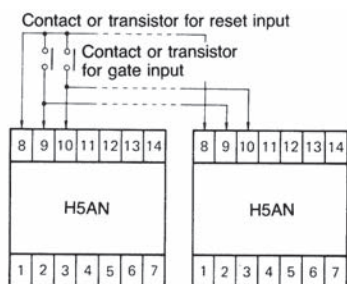



# Safety Precautions

● Be sure to read the precautions for all Timers in the website at: <http://www.ia.omron.com/>.

## Warning Indications

 <b>CAUTION</b>	Indicates a potentially hazardous situation which, if not avoided, may result in minor or moderate injury or in property damage.
<b>Precautions for Safe Use</b>	Supplementary comments on what to do or avoid doing, to use the product safely.
<b>Precautions for Correct Use</b>	Supplementary comments on what to do or avoid doing, to prevent failure to operate, malfunction or undesirable effect on product performance.

## Meaning of Product Safety Symbols

	Used to warn of the risk of electric shock under specific conditions.
	Used for general prohibitions for which there is no specific symbol.
	Used for general mandatory action precautions for which there is no specified symbol.

### CAUTION

Do not touch the terminals while power is being supplied. Doing so may occasionally result in minor injury due to electric shock.



Do not use the product where subject to flammable or explosive gas.

Otherwise, minor injury from explosion may occasionally occur.



Never disassemble, modify or repair the product or touch any of the internal parts. Minor electric shock, fire, or malfunction may occasionally occur.

The life expectancy of output relays varies considerably with the output load and switching conditions. Always consider the application conditions and use the output relays within their rated load and electrical life expectancy. If the output relays are used past their life expectancy, contact fusing or burning may occasionally occur. Also, never exceed the rated load current. When using a heater, surely use a thermo switch in the load circuit.



Tighten the terminal screws to between 0.74 and 0.90 N·m.

Loose screws may occasionally result in fire.



Do not allow pieces of metal, wire clippings, or fine metallic shavings or filings from installation to enter the product. Doing so may occasionally result in electric shock, fire, or malfunction.



## Precautions for Safe Use

- Make sure the proper product is specified for the application.
- For correct use, do not subject the product to the following conditions.
  - Dramatic temperature fluctuations
  - High humidity or where condensation may occur
  - Severe vibration and shock
  - Where excessive dust, corrosive gas, or direct sunlight may be present
- This product is not waterproof or oil resistance. Do not use the product in any of the places subject to splashing liquid or oil atmosphere.
- Use and store the product within the rated ranges given for the product model you are using. If necessary, use forced cooling. If the product is stored below  $-10^{\circ}\text{C}$ , allow it to warm up for three hours at room temperature before turning ON the power supply.
- Do not cover the vent holes on the products and the area around the product in order to ensure thermal dissipation.
- Wiring all terminals correctly.
- Do not wire the terminals which are not used.
- Use specified size crimped terminals (M3.5, thickness 7.2 mm max.) for wiring with a gage of AWG 24 to AWG 18 (equal to a cross section area of 0.205 to 0.823 mm<sup>2</sup>). (The wiring stripping length is 5 to 6 mm.)
  - Up to two wires of same size and type, or two crimped terminals can be inserted into a single terminal.
- Use this product within the rated power supply voltage and control output.
- Use a switch, relay, or other contact to turn the power supply ON instantaneously. If the voltage is applied gradually, the power may not be reset or output malfunctions may occur.
- Interlock the power to the product with a relay so that the product will not be left in an output-on condition for long periods. Leaving the product in an output-on condition for a month or longer, especially in places with high temperatures, may result in deterioration to internal parts, such as an electrolytic capacitor.
- Internal circuit voltage (12 V) is output to the no-voltage input terminals, which may cause some connected devices to malfunction or fail. Check the specifications of the input device (e.g., rated output voltage or whether a power supply circuit diode is built in).
  - To prevent power supply devices from being subjected to charging accidents, connect a diode as in the diagram when using a power supply voltage of 12 V or less to operate input devices that do not have a diode built into the power supply circuit.
- Do not apply the supply voltage directly from external to transistor output and external power supply terminal.
- Check that the LED indicators are operating normally. Depending on the operating environment, the indicators and plastic parts may deteriorate faster than expected, causing the indicators to fail. Periodically perform inspections and replacements.
- When changing the set time while power is being supplied, an inadequate push of the thumb wheel switches will display two numbers in one display window, causing the operating count to drift widely. Therefore, press the thumb wheel switches surely. Take particular care when the other three digits are all zeroes, because the improper setting of the fourth switch to create four zeroes will cause an instantaneous output.

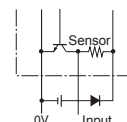

(Undesirable Setting) → (Possible Operating Time)

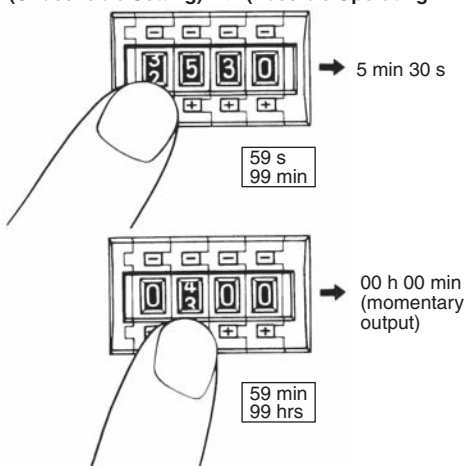

- Turn the power OFF first when removing the body from the case, never touch the terminals or electronic components with your hands or subject them to shock. When inserting the body, do not allow electronic components to come in contact with the case.
- Static electricity may destroy internal components. When removing the body from the case, do not touch an electronic components other than the setting switches with your hands.
- Use tools when separating parts for disposal.
- When disposing of the product, observe all local ordinances as they apply.

### Precautions for Correct Use

- Inrush current will be carried when turning on the power. If the capacity of the power for the product is insufficient, the product cannot start. Use a power supply, breakers, contacts which sufficient capacity.  
100 to 240 VAC specifications Approx. 23 A for 264 VAC  
100 VDC Approx. 8 A for 100 VDC  
12 to 24 VDC specifications Approx. 15 A for 26.4 VDC
- Since 50 ms after the power is turned ON is required as the raise time of the internal circuit voltage, note that the product may not operate in response to any input signal during this period.
- Since 50 ms after the power is turned OFF (or momentary power failures) is required as the fall time of the internal circuit voltage, note that the product may respond to input signals during this period.

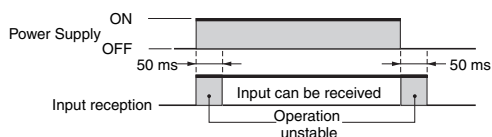

- Models without power failure memory backup or models ending with "-M" (when memory backup is disabled) will operate as shown in the following figure if the power supply is momentarily interrupted.

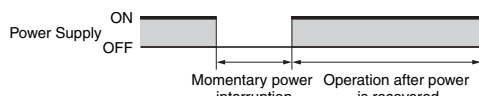

0.5 s min.	Displays and outputs will be reset.
0.01 s max.	The status before the power interruption will be held.
0.01 to 0.5 s	Operation will be unstable, i.e., one of the above operations will be performed.

**Note:** Use a Timer with power failure backup memory (models ending with -M) and enable memory backup if holding the status before the power failure is required when the power is interrupted.

- The display will be as shown below when a reset (external or manual) is input.

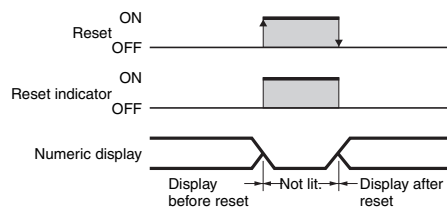

## Setting of Operating Time

### Time Setting Range

Rated time	Setting range
99.99 s	0.01 to 99.99 s (see note)
999.9 s	0.1 to 999.9 s (see note)
9999 s	1 to 9999 s
99 min 59 s	1 s to 99 min 59 s
999.9 min	0.1 to 999.9 min (see note)
99 hrs 59 min	1 min to 99 hrs 59 min
999.9 hrs	0.1 to 999.9 hrs (see note)
9999 hrs	1 to 9999 hrs

**Note:** The decimal point is not shown in the digital display.

- Since the H5AN Timer is capable of reading the input data at any time during normal operation, the set time can be changed during power application. This feature sets back the output from the timer by temporarily setting the longer time or quickens the output by setting the shorter time. During normal operation, the set time may be accidentally changed by touching a thumbwheel switch, causing the timer to operate with a different set time. To prevent this possibility, keep the front cover closed except when changing the set time.
- When the set time is all zeroes (e.g., 000.0 s or 00 hrs 00 min), there will be a momentary control output upon power application which can be used to check normal output. When changing the set time during normal operation, pay attention not to alter the set value to this all zeros.
- Since the sexagesimal system is adopted, when a rated time of 99 min 59 s or 99 hrs 59 min is selected, any value set to 6 or more (i.e. 6-9) in the order of x 10 s or x 10 min respectively will be rated as 5. Some erroneous setting examples are shown below.

### Examples of Setting/Actual Operating Time

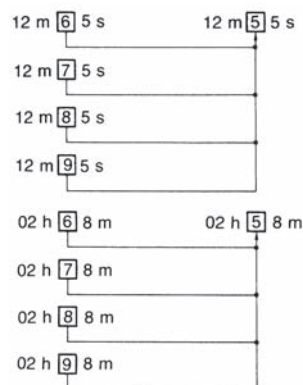

- To mount the casing on the digital timer, insert the digital timer body into the casing by hand as far as possible and then tighten the mounting screw. Press by the hand the front panel as indicated by the arrow so that the screw will tighten securely.

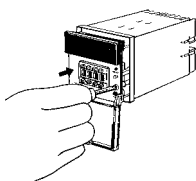

## ■ Changes in Specifications

The Timer manufactured in April 2014 or after will be upgraded. The major changes are described below.

### 1. H5AN-4DM Memory Backup

Previously a backup battery (built-in) was used, but this will be changed to non-volatile memory.

### 2. Addition of Setting to Enable and Disable Memory Backup

The H5AN-4DM has a DIP switch setting to enable or disable memory backup.

## Power Failure Backup Memory

- The product memorizes the status just before occurring the electric failure memory with non-volatile memory. The rewriting lifespan of the non-volatile memory is 1,000,000 or more. The non-volatile memory rewrites the setting condition into the initial setting one when the power OFF. (-M type only)

## ■ Self-diagnostic Function

When an error has occurred, the bellow error codes are shown.

7 segment display	Time UP display	Description	Output
E1	OFF	CPU error	OFF
E2	OFF	Memory error (RAM)	OFF
E3	OFF	Memory error (non-volatile memory)*	OFF

\* Including the case when the rewriting lifespan of the nonvolatile memory is reached.

### Recovery method

As an action, turn the power OFF then back ON again. If the display restored to normal, then a probable cause can be external noise affecting the system. Check for external noise. In the case of E3, input gate ("0000" will be displayed) and turn power ON again. After that, if it still remains the same, the product must be repaired.

ALL DIMENSIONS SHOWN ARE IN MILLIMETERS.

To convert millimeters into inches, multiply by 0.03937. To convert grams into ounces, multiply by 0.03527.

In the interest of product improvement, specifications are subject to change without notice.

## Terms and Conditions Agreement

### Read and understand this catalog.

Please read and understand this catalog before purchasing the products. Please consult your OMRON representative if you have any questions or comments.

### Warranties.

(a) Exclusive Warranty. Omron's exclusive warranty is that the Products will be free from defects in materials and workmanship for a period of twelve months from the date of sale by Omron (or such other period expressed in writing by Omron). Omron disclaims all other warranties, express or implied.

(b) Limitations. OMRON MAKES NO WARRANTY OR REPRESENTATION, EXPRESS OR IMPLIED, ABOUT NON-INFRINGEMENT, MERCHANTABILITY OR FITNESS FOR A PARTICULAR PURPOSE OF THE PRODUCTS. BUYER ACKNOWLEDGES THAT IT ALONE HAS DETERMINED THAT THE PRODUCTS WILL SUITABLY MEET THE REQUIREMENTS OF THEIR INTENDED USE.

Omron further disclaims all warranties and responsibility of any type for claims or expenses based on infringement by the Products or otherwise of any intellectual property right. (c) Buyer Remedy. Omron's sole obligation hereunder shall be, at Omron's election, to (i) replace (in the form originally shipped with Buyer responsible for labor charges for removal or replacement thereof) the non-complying Product, (ii) repair the non-complying Product, or (iii) repay or credit Buyer an amount equal to the purchase price of the non-complying Product; provided that in no event shall Omron be responsible for warranty, repair, indemnity or any other claims or expenses regarding the Products unless Omron's analysis confirms that the Products were properly handled, stored, installed and maintained and not subject to contamination, abuse, misuse or inappropriate modification. Return of any Products by Buyer must be approved in writing by Omron before shipment. Omron Companies shall not be liable for the suitability or unsuitability or the results from the use of Products in combination with any electrical or electronic components, circuits, system assemblies or any other materials or substances or environments. Any advice, recommendations or information given orally or in writing, are not to be construed as an amendment or addition to the above warranty.

See <http://www.omron.com/global/> or contact your Omron representative for published information.

### Limitation on Liability; Etc.

OMRON COMPANIES SHALL NOT BE LIABLE FOR SPECIAL, INDIRECT, INCIDENTAL, OR CONSEQUENTIAL DAMAGES, LOSS OF PROFITS OR PRODUCTION OR COMMERCIAL LOSS IN ANY WAY CONNECTED WITH THE PRODUCTS, WHETHER SUCH CLAIM IS BASED IN CONTRACT, WARRANTY, NEGLIGENCE OR STRICT LIABILITY.

Further, in no event shall liability of Omron Companies exceed the individual price of the Product on which liability is asserted.

### Suitability of Use.

Omron Companies shall not be responsible for conformity with any standards, codes or regulations which apply to the combination of the Product in the Buyer's application or use of the Product. At Buyer's request, Omron will provide applicable third party certification documents identifying ratings and limitations of use which apply to the Product. This information by itself is not sufficient for a complete determination of the suitability of the Product in combination with the end product, machine, system, or other application or use. Buyer shall be solely responsible for determining appropriateness of the particular Product with respect to Buyer's application, product or system. Buyer shall take application responsibility in all cases.

NEVER USE THE PRODUCT FOR AN APPLICATION INVOLVING SERIOUS RISK TO LIFE OR PROPERTY OR IN LARGE QUANTITIES WITHOUT ENSURING THAT THE SYSTEM AS A WHOLE HAS BEEN DESIGNED TO ADDRESS THE RISKS, AND THAT THE OMRON PRODUCT(S) IS PROPERLY RATED AND INSTALLED FOR THE INTENDED USE WITHIN THE OVERALL EQUIPMENT OR SYSTEM.

### Programmable Products.

Omron Companies shall not be responsible for the user's programming of a programmable Product, or any consequence thereof.

### Performance Data.

Data presented in Omron Company websites, catalogs and other materials is provided as a guide for the user in determining suitability and does not constitute a warranty. It may represent the result of Omron's test conditions, and the user must correlate it to actual application requirements. Actual performance is subject to the Omron's Warranty and Limitations of Liability.

### Change in Specifications.

Product specifications and accessories may be changed at any time based on improvements and other reasons. It is our practice to change part numbers when published ratings or features are changed, or when significant construction changes are made. However, some specifications of the Product may be changed without any notice. When in doubt, special part numbers may be assigned to fix or establish key specifications for your application. Please consult with your Omron's representative at any time to confirm actual specifications of purchased Product.

### Errors and Omissions.

Information presented by Omron Companies has been checked and is believed to be accurate; however, no responsibility is assumed for clerical, typographical or proofreading errors or omissions.

2014.4

In the interest of product improvement, specifications are subject to change without notice.

**OMRON Corporation**  
Industrial Automation Company

<http://www.ia.omron.com/>

(c)Copyright OMRON Corporation 2014 All Right Reserved.