

TOSHIBA CMOS Digital Integrated Circuit Silicon Monolithic

TC74AC164P, TC74AC164F, TC74AC164FN, TC74AC164FT

8-Bit Shift Register (S-IN, P-OUT)

The TC74AC164 is an advanced high speed CMOS 8-BIT SERIAL-IN PARALLEL-OUT SHIFT REGISTER fabricated with silicon gate and double-layer metal wiring C²MOS technology.

It achieves the high speed operation similar to equivalent Bipolar Schottky TTL while maintaining the CMOS low power dissipation.

It consists of a serial-in, parallel-out 8-bit shift register with a CLOCK input and an overriding $\overline{\text{CLEAR}}$ input.

Two serial data inputs (A, B) are provided so that one may be used as a data enable.

All inputs are equipped with protection circuits against static discharge or transient excess voltage.

Features

- High speed: $f_{\text{max}} = 170 \text{ MHz}$ (typ.) at $V_{\text{CC}} = 5 \text{ V}$
- Low power dissipation: $I_{\text{CC}} = 8 \mu\text{A}$ (max) at $T_a = 25^\circ\text{C}$
- High noise immunity: $V_{\text{NIH}} = V_{\text{NIL}} = 28\% V_{\text{CC}}$ (min)
- Symmetrical output impedance:
 $|I_{\text{OH}}| = I_{\text{OL}} = 24 \text{ mA}$ (min)
 Capability of driving 50Ω transmission lines.
- Balanced propagation delays: $t_{\text{pLH}} \approx t_{\text{pHL}}$
- Wide operating voltage range: $V_{\text{CC}} (\text{opr}) = 2 \text{ V}$ to 5.5 V
- Pin and function compatible with 74F164

Note: xxxFN (JEDEC SOP) is not available in Japan.

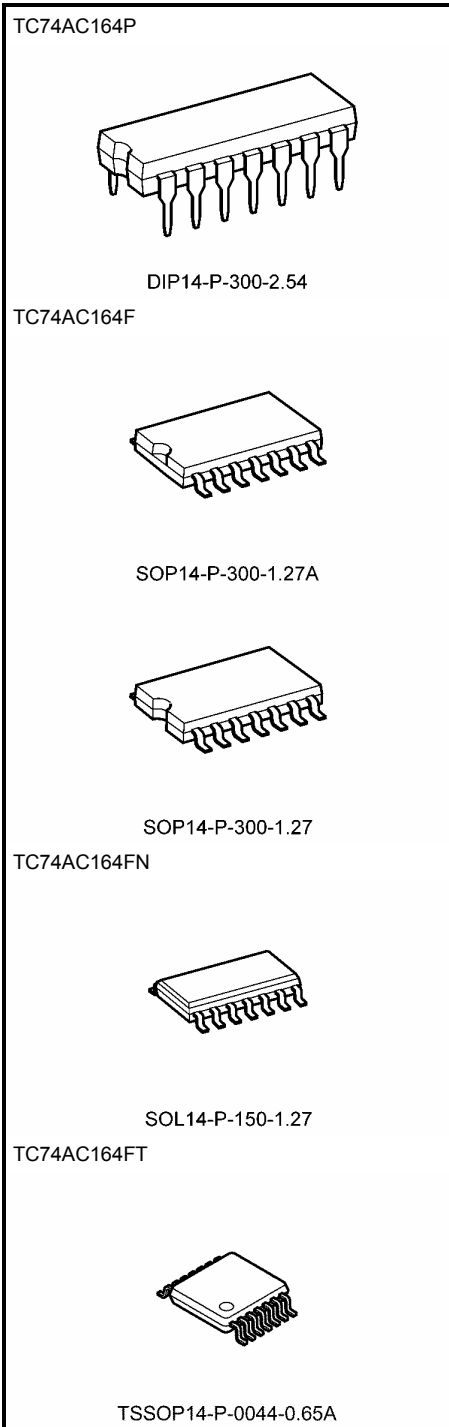

Weight	
DIP14-P-300-2.54	: 0.96 g (typ.)
SOP14-P-300-1.27A	: 0.18 g (typ.)
SOP14-P-300-1.27	: 0.18 g (typ.)
SOL14-P-150-1.27	: 0.12 g (typ.)
TSSOP14-P-0044-0.65A	: 0.06 g (typ.)

Pin Assignment

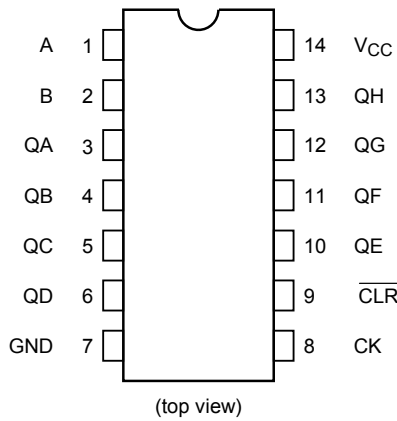

IEC Logic Symbol

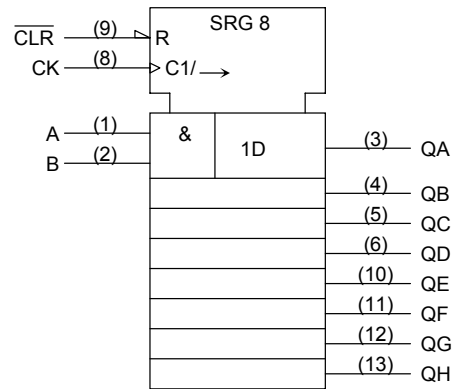

Truth Table

Inputs				Outputs			
$\overline{\text{CLR}}$	CK	Serial In		QA	QB	...	QH
		A	B				
L	X	X	X	L	L	...	L
H		X	X	No Change			
H		L	X	L	QA _n	...	QG _n
H		X	L	L	QA _n	...	QG _n
H		H	H	H	QA _n	...	QG _n

X: Don't care

QA_n to QG_n: The level of QA to QG, respectively, before the most recent positive edge of the clock.

System Diagram

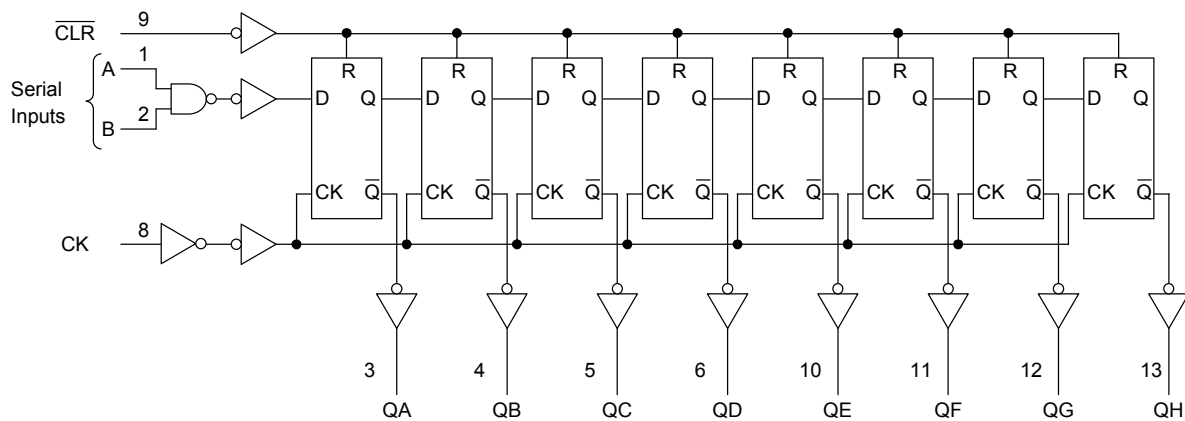

Timing Chart

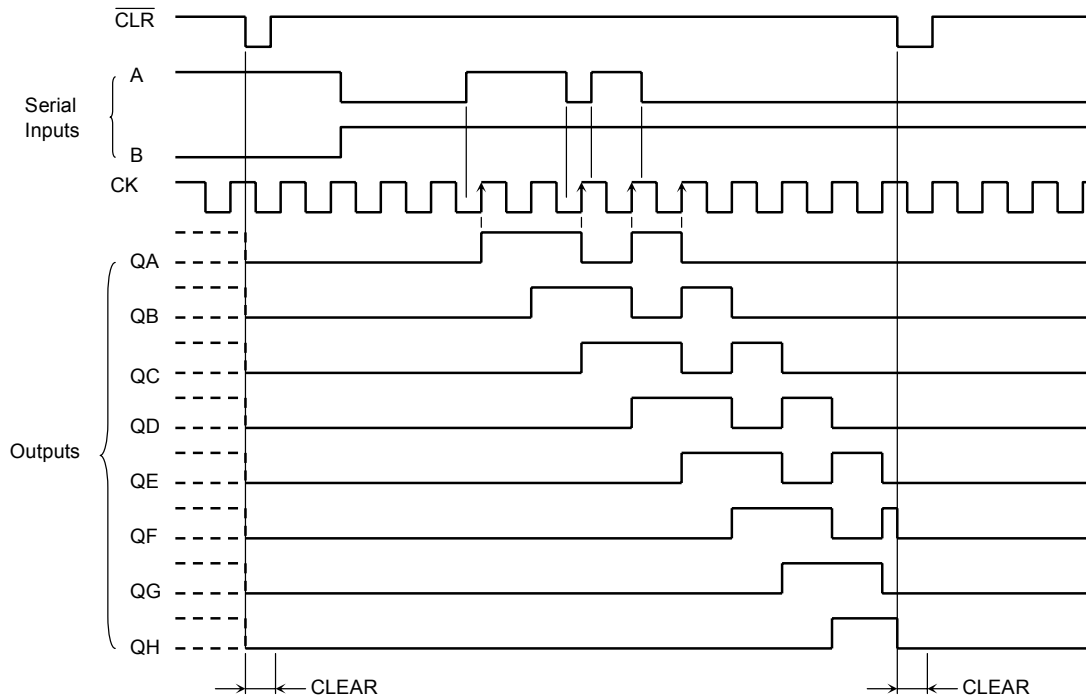

Absolute Maximum Ratings (Note 1)

Characteristics	Symbol	Rating	Unit
Supply voltage range	V_{CC}	-0.5 to 7.0	V
DC input voltage	V_{IN}	-0.5 to $V_{CC} + 0.5$	V
DC output voltage	V_{OUT}	-0.5 to $V_{CC} + 0.5$	V
Input diode current	I_{IK}	± 20	mA
Output diode current	I_{OK}	± 50	mA
DC output current	I_{OUT}	± 50	mA
DC V_{CC} /ground current	I_{CC}	± 200	mA
Power dissipation	P_D	500 (DIP) (Note 2)/180 (SOP/TSSOP)	mW
Storage temperature	T_{stg}	-65 to 150	$^{\circ}C$

Note1: Exceeding any of the absolute maximum ratings, even briefly, lead to deterioration in IC performance or even destruction.

Note2: 500 mW in the range of $T_a = -40^{\circ}C$ to $65^{\circ}C$. From $T_a = 65^{\circ}C$ to $85^{\circ}C$ a derating factor of -10 mW/ $^{\circ}C$ should be applied up to 300 mW.

Recommended Operating Conditions (Note)

Characteristics	Symbol	Rating	Unit
Supply voltage	V_{CC}	2.0 to 5.5	V
Input voltage	V_{IN}	0 to V_{CC}	V
Output voltage	V_{OUT}	0 to V_{CC}	V
Operating temperature	T_{opr}	-40 to 85	°C
Input rise and fall time	dt/dV	0 to 100 ($V_{CC} = 3.3 \pm 0.3$ V) 0 to 20 ($V_{CC} = 5 \pm 0.5$ V)	ns/V

Note: The recommended operating conditions are required to ensure the normal operation of the device.
Unused inputs must be tied to either V_{CC} or GND.

Electrical Characteristics

DC Characteristics

Characteristics	Symbol	Test Condition	$T_a = 25^\circ\text{C}$			$T_a = -40$ to 85°C		Unit		
			V_{CC} (V)	Min	Typ.	Max	Min		Max	
High-level input voltage	V_{IH}	—	2.0	1.50	—	—	1.50	—	V	
			3.0	2.10	—	—	2.10	—		
			5.5	3.85	—	—	3.85	—		
Low-level input voltage	V_{IL}	—	2.0	—	—	0.50	—	0.50	V	
			3.0	—	—	0.90	—	0.90		
			5.5	—	—	1.65	—	1.65		
High-level output voltage	V_{OH}	$V_{IN} = V_{IH}$ or V_{IL}	$I_{OH} = -50 \mu\text{A}$	2.0	1.9	2.0	—	1.9	—	V
				3.0	2.9	3.0	—	2.9	—	
				4.5	4.4	4.5	—	4.4	—	
				5.5	—	—	—	—	—	
Low-level output voltage	V_{OL}	$V_{IN} = V_{IH}$ or V_{IL}	$I_{OL} = 50 \mu\text{A}$	2.0	—	0.0	0.1	—	0.1	V
				3.0	—	0.0	0.1	—	0.1	
				4.5	—	0.0	0.1	—	0.1	
				5.5	—	—	—	—	—	
Low-level output voltage	V_{OL}	$V_{IN} = V_{IH}$ or V_{IL}	$I_{OL} = 12 \text{ mA}$	3.0	—	—	0.36	—	0.44	V
				4.5	—	—	0.36	—	0.44	
				5.5	—	—	—	—	1.65	
				5.5	—	—	—	—	—	
Input leakage current	I_{IN}	$V_{IN} = V_{CC}$ or GND	5.5	—	—	± 0.1	—	± 1.0	μA	
Quiescent supply current	I_{CC}	$V_{IN} = V_{CC}$ or GND	5.5	—	—	8.0	—	80.0	μA	

Note: This spec indicates the capability of driving 50 Ω transmission lines.
One output should be tested at a time for a 10 ms maximum duration.

Timing Requirements (input: $t_r = t_f = 3 \text{ ns}$)

Characteristics	Symbol	Test Condition	Ta = 25°C		Ta = -40 to 85°C		Unit
			V _{CC} (V)	Limit	Limit	Limit	
Minimum pulse width (CK)	t _w (L)	—	3.3 ± 0.3	9.0	10.0	ns	
	t _w (H)		5.0 ± 0.5	5.0	6.0		
Minimum pulse width ($\overline{\text{CLR}}$)	t _w (L)	—	3.3 ± 0.3	9.0	10.0	ns	
			5.0 ± 0.5	5.0	6.0		
Minimum set-up time	t _s	—	3.3 ± 0.3	7.0	7.0	ns	
			5.0 ± 0.5	4.0	4.0		
Minimum hold time	t _h	—	3.3 ± 0.3	1.0	1.0	ns	
			5.0 ± 0.5	1.0	1.0		
Minimum removal time ($\overline{\text{CLR}}$)	t _{rem}	—	3.3 ± 0.3	8.5	8.5	ns	
			5.0 ± 0.5	5.0	5.0		

AC Characteristics (C_L = 50 pF, R_L = 500 Ω, input: $t_r = t_f = 3 \text{ ns}$)

Characteristics	Symbol	Test Condition	Ta = 25°C			Ta = -40 to 85°C		Unit	
			V _{CC} (V)	Min	Typ.	Max	Min		Max
Propagation delay time (CK-Q)	t _{pLH}	—	3.3 ± 0.3	—	9.6	16.3	1.0	18.6	ns
	t _{pHL}		5.0 ± 0.5	—	6.6	9.8	1.0	11.2	
Propagation delay time ($\overline{\text{CLR}}$ -Q)	t _{pHL}	—	3.3 ± 0.3	—	8.0	15.4	1.0	17.5	ns
			5.0 ± 0.5	—	6.0	11.0	1.0	12.5	
Maximum clock frequency	f _{max}	—	3.3 ± 0.3	45	100	—	45	—	MHz
			5.0 ± 0.5	85	150	—	80	—	
Input capacitance	C _{IN}	—	—	5	10	—	10	pF	
Power dissipation capacitance	C _{PD}	(Note)	—	110	—	—	—	pF	

Note: C_{PD} is defined as the value of the internal equivalent capacitance which is calculated from the operating current consumption without load.

Average operating current can be obtained by the equation:

$$I_{CC(\text{opr})} = C_{PD} \cdot V_{CC} \cdot f_{IN} + I_{CC}$$

Package Dimensions

DIP14-P-300-2.54

Unit : mm

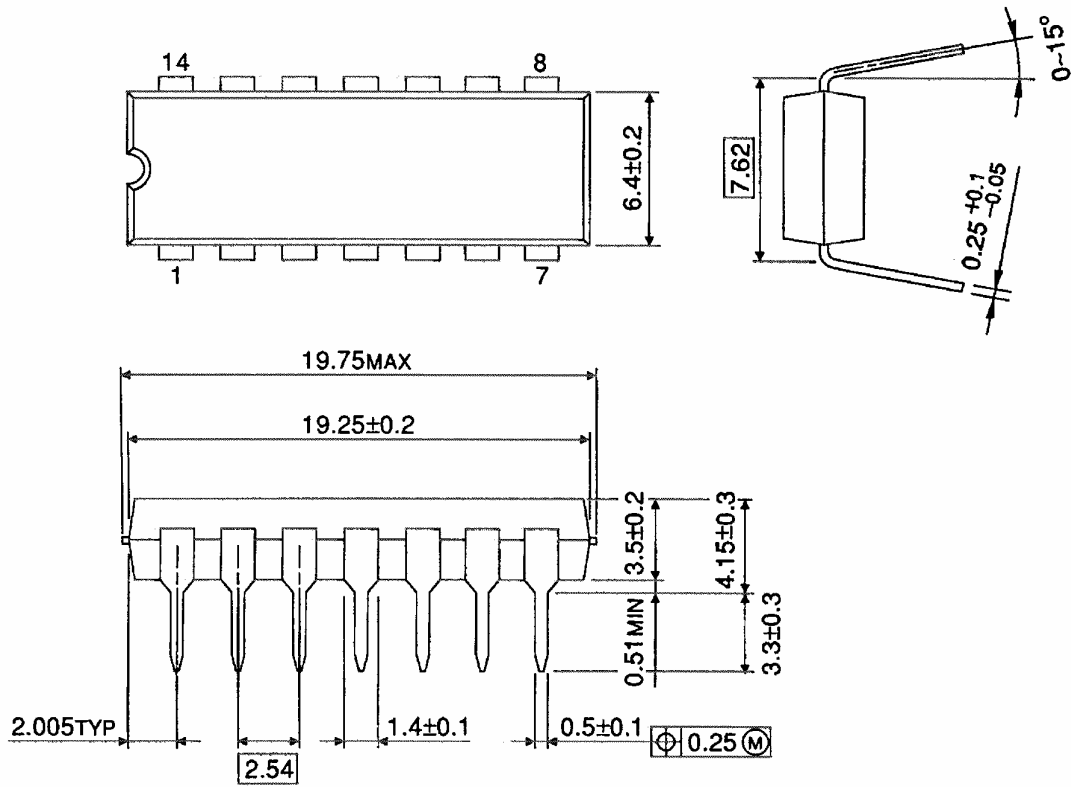

Weight: 0.96 g (typ.)

Package Dimensions

SOP14-P-300-1.27A

Unit: mm

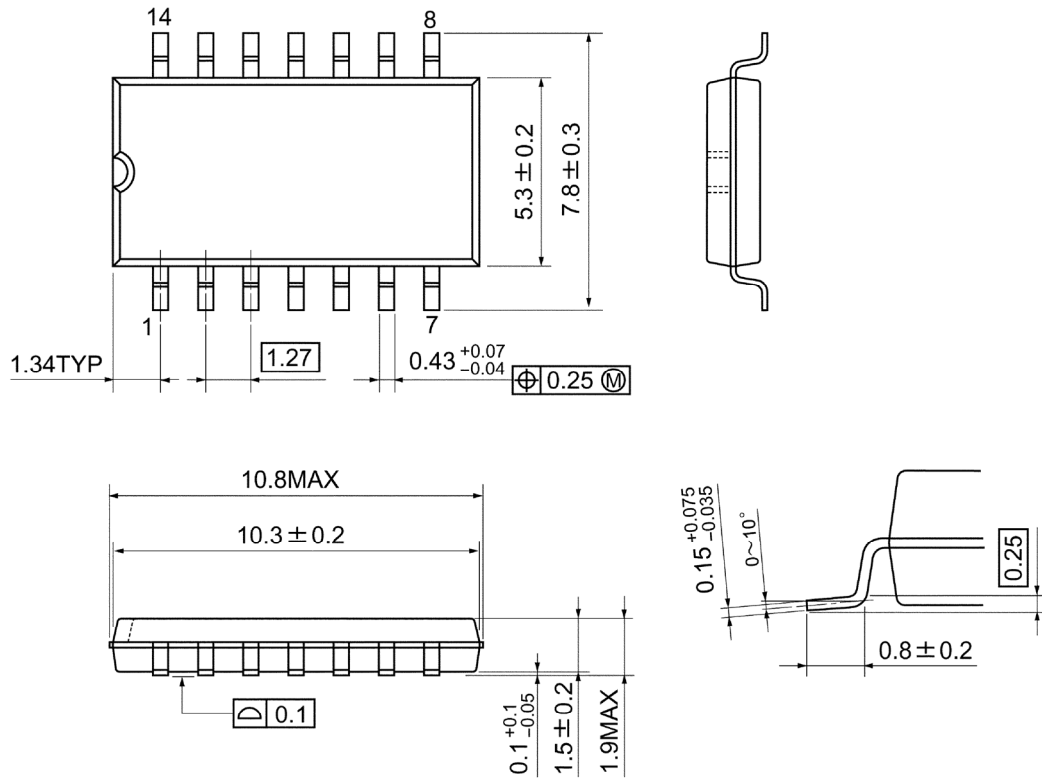

Weight: 0.18 g (typ.)

Package Dimensions

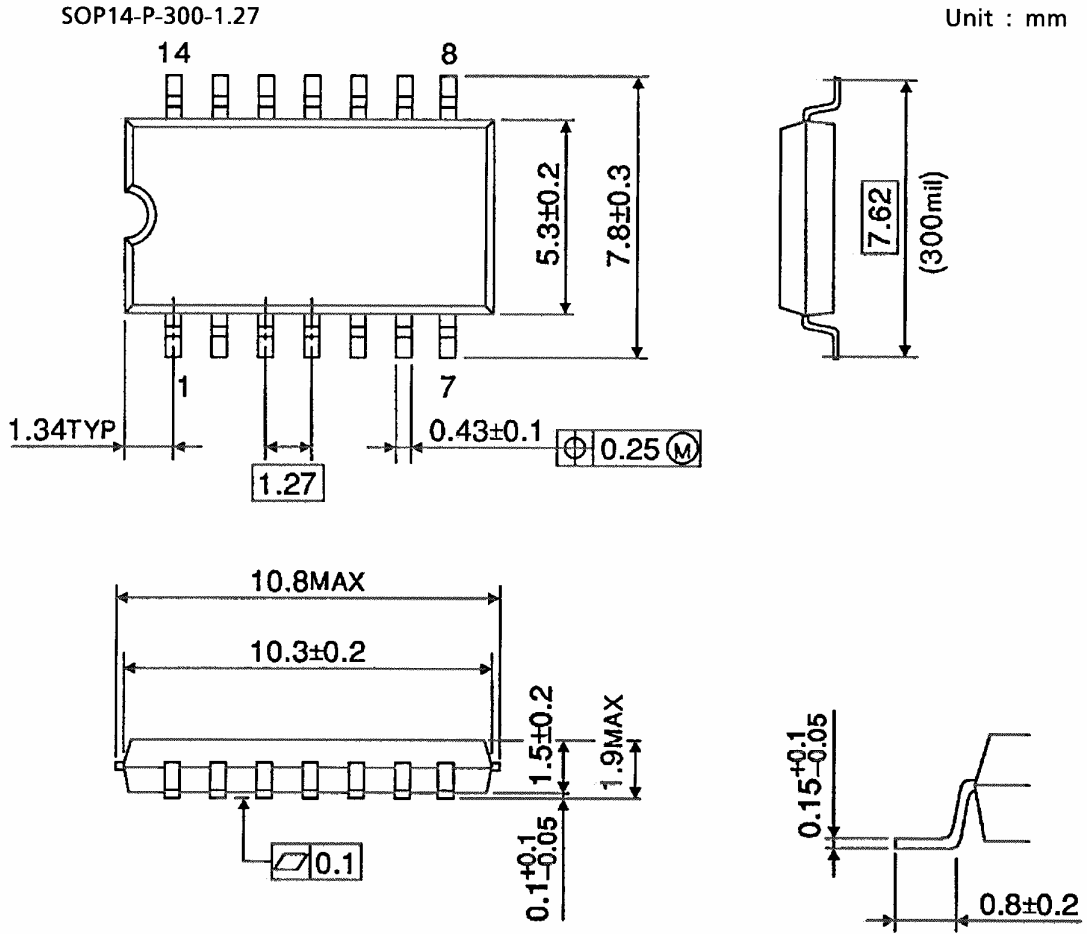

Weight: 0.18 g (typ.)

Package Dimensions (Note)

SOL14-P-150-1.27

Unit : mm

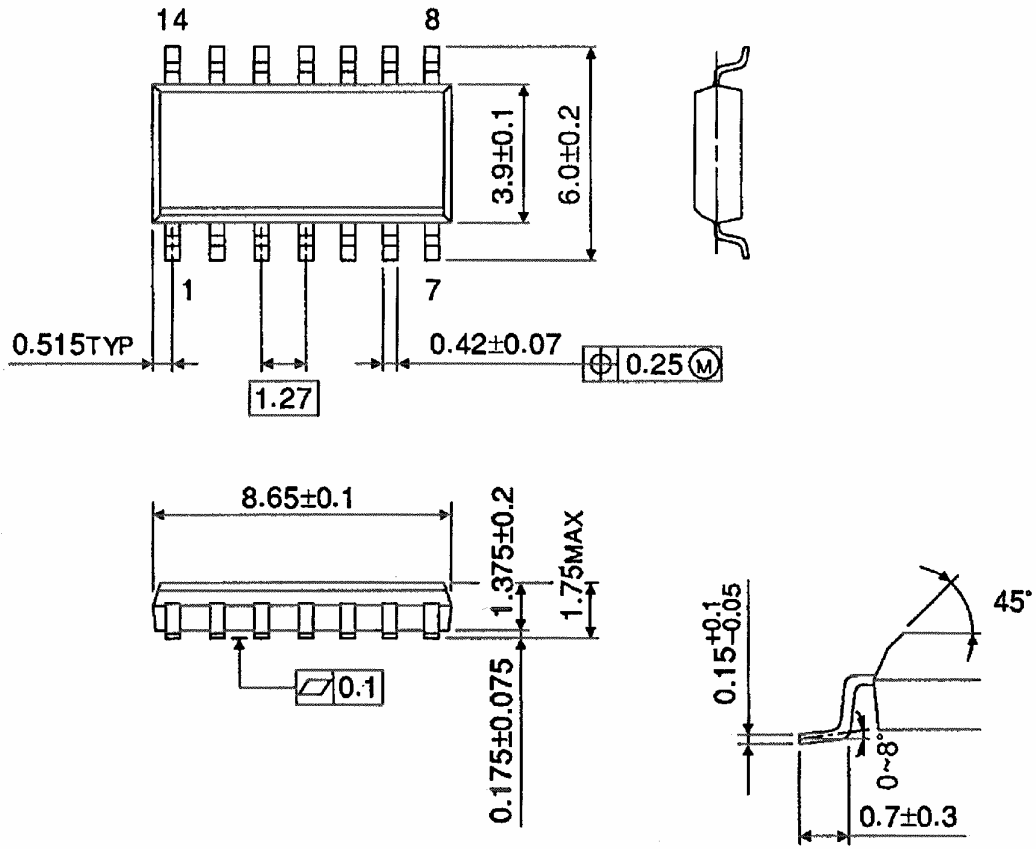

Note: This package is not available in Japan.

Weight: 0.12 g (typ.)

Package Dimensions

TSSOP14-P-0044-0.65A

Unit: mm

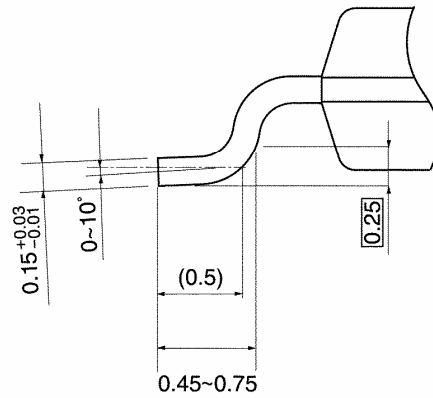
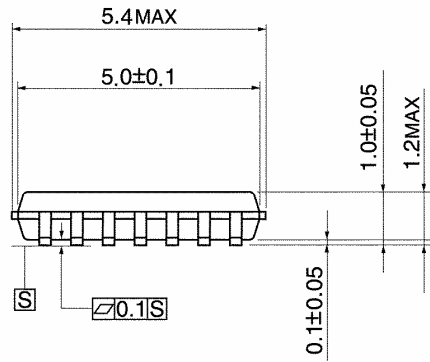
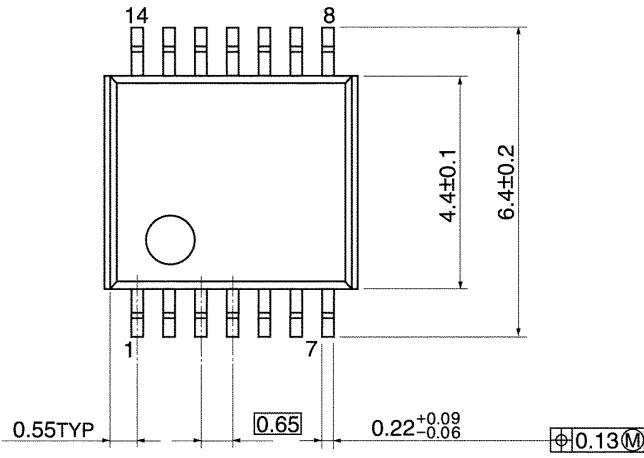

Weight: 0.06 g (typ.)

Note: Lead (Pb)-Free Packages**DIP14-P-300-2.54 SOP14-P-300-1.27A SOL14-P-150-1.27 TSSOP14-P-0044-0.65A****RESTRICTIONS ON PRODUCT USE**

060116EBA

- The information contained herein is subject to change without notice. 021023_D
- TOSHIBA is continually working to improve the quality and reliability of its products. Nevertheless, semiconductor devices in general can malfunction or fail due to their inherent electrical sensitivity and vulnerability to physical stress. It is the responsibility of the buyer, when utilizing TOSHIBA products, to comply with the standards of safety in making a safe design for the entire system, and to avoid situations in which a malfunction or failure of such TOSHIBA products could cause loss of human life, bodily injury or damage to property.
In developing your designs, please ensure that TOSHIBA products are used within specified operating ranges as set forth in the most recent TOSHIBA products specifications. Also, please keep in mind the precautions and conditions set forth in the "Handling Guide for Semiconductor Devices," or "TOSHIBA Semiconductor Reliability Handbook" etc. 021023_A
- The TOSHIBA products listed in this document are intended for usage in general electronics applications (computer, personal equipment, office equipment, measuring equipment, industrial robotics, domestic appliances, etc.). These TOSHIBA products are neither intended nor warranted for usage in equipment that requires extraordinarily high quality and/or reliability or a malfunction or failure of which may cause loss of human life or bodily injury ("Unintended Usage"). Unintended Usage include atomic energy control instruments, airplane or spaceship instruments, transportation instruments, traffic signal instruments, combustion control instruments, medical instruments, all types of safety devices, etc. Unintended Usage of TOSHIBA products listed in this document shall be made at the customer's own risk. 021023_B
- The products described in this document shall not be used or embedded to any downstream products of which manufacture, use and/or sale are prohibited under any applicable laws and regulations. 060106_Q
- The information contained herein is presented only as a guide for the applications of our products. No responsibility is assumed by TOSHIBA for any infringements of patents or other rights of the third parties which may result from its use. No license is granted by implication or otherwise under any patent or patent rights of TOSHIBA or others. 021023_C
- The products described in this document are subject to the foreign exchange and foreign trade laws. 021023_E