

# Full-Bridge PWM Microstepping Motor Driver

## Features and Benefits

- ±1.5 A continuous output current
- 50 V output voltage rating
- Internal PWM current control
- 3-bit nonlinear DAC
- Fast, mixed fast/slow, and slow current-decay modes
- Internal thermal shutdown circuitry
- Crossover-current and UVLO protection

## Packages:

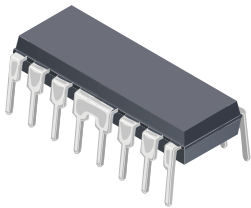

Package B, 16-pin DIP with exposed tabs

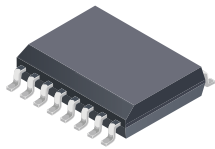

Package LB, 16-pin SOIC with internally fused pins

Not to scale

## Description

The A4975 is designed to drive one winding of a bipolar stepper motor in a microstepping mode. The outputs are rated for continuous output currents to ±1.5 A and operating voltages to 50 V. Internal pulse width modulated (PWM) current control combined with an internal three-bit nonlinear digital-to-analog converter allows the motor current to be controlled in full-, half-, quarter-, or eighth-step (microstepping) modes. Nonlinear increments minimize the number of control lines necessary for microstepping. Microstepping provides increased step resolution, and reduces torque variations and resonance problems at low speed.

Internal circuitry determines whether the PWM current-control circuitry operates in a slow (recirculating) current-decay mode, fast (regenerative) current-decay mode, or in a mixed current-decay mode in which the off-time is divided into a period of fast current decay and with the remainder of the fixed off-time spent in slow current decay. The combination of user-selectable current-sensing resistor and reference voltage, digitally selected output current ratio; and slow, fast, or mixed current-decay modes provides users with a broad, variable range of motor control.

Continued on the next page...

## Functional Block Diagram

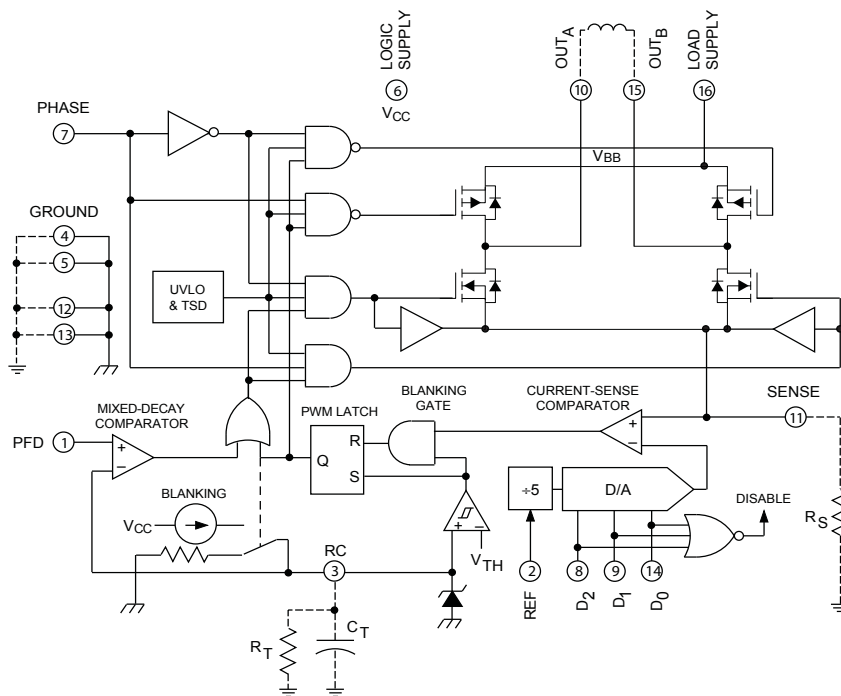

# A4975

# Full-Bridge PWM Microstepping Motor Driver

## Description (continued)

Internal circuit protection includes thermal shutdown with hysteresis, an undervoltage monitor, and crossover-current protection. Special power-up sequencing is not required.

The A4975 is supplied in a choice of two power packages; a 16-pin dual-in-line plastic package with copper heat-sink tabs (suffix 'B'),

and a 16-lead plastic SOIC with internally fused pins (suffix 'LB'). For both package styles, the thermally enhanced pins are at ground potential and need no electrical isolation. Both packages are lead (Pb) free, with leadframe plating 100% matte tin.

## Selection Guide

Part Number	Packing	Package
A4975SB-T	16-pin DIP with exposed thermal tabs	25 per tube
A4975SLBTR-T	16-pin SOICW with internally fused pins	1000 per reel

## Absolute Maximum Ratings

Characteristic	Symbol	Notes	Rating	Units
Load Supply Voltage	$V_{BB}$		50	V
Logic Supply Voltage	$V_{CC}$		6	V
Logic/Reference Input Voltage Range	$V_{IN}$		-0.3 to 6	V
Sense Voltage	$V_S$		0.5	V
Output Current, Continuous	$I_{OUT}$	Output current rating may be limited by duty cycle, ambient temperature, and heat sinking. Under any set of conditions, do not exceed the specified current rating or a junction temperature of 150°C.	±1.5	A
Package Power Dissipation	$P_D$		See graph	W
Operating Ambient Temperature	$T_A$	Range S	-20 to 85	°C
Maximum Junction Temperature	$T_J(\text{max})$	Fault conditions that produce excessive junction temperature will activate the device's thermal shutdown circuitry. These conditions can be tolerated but should be avoided.	150	°C
Storage Temperature	$T_{stg}$		-55 to 150	°C

## Thermal Characteristics

Characteristic	Symbol	Test Conditions*	Value	Units
Package Thermal Resistance, Junction to Ambient	$R_{\theta JA}$	B Package, single-layer PCB, 1 in <sup>2</sup> 2-oz. exposed copper	43	°C/W
		LB Package, 2-layer PCB, 0.3 in <sup>2</sup> 2-oz. exposed copper each side	67	°C/W
Package Thermal Resistance, Junction to Tab	$R_{\theta JT}$		6	°C/W

\*Additional thermal information available on Allegro website.

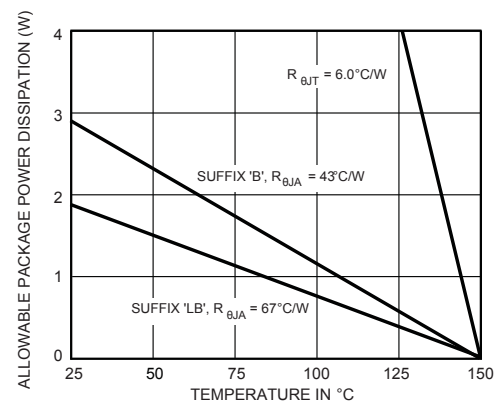

**ELECTRICAL CHARACTERISTICS at  $T_A = 25^\circ\text{C}$ ,  $V_{CC} = 4.5$  to  $5.5$  V (unless otherwise noted.)**

Characteristic	Symbol	Test Conditions	Min.	Typ.	Max.	Unit
<b>Power Outputs</b>						
Load Supply Voltage Range	$V_{BB}$	Operating	5	—	50	V
Output Leakage Current	$I_{CEX}$	$V_{OUT} = V_{BB}$	—	<1.0	50	$\mu\text{A}$
		$V_{OUT} = 0$ V	—	<-1.0	-50	$\mu\text{A}$
Output Resistance	$R_{DS}$	Total Sink + Source, $I_{OUT} = 1.5$ A, $V_{BB} > 8$ V, $T_J = 25^\circ\text{C}$	—	1	1.4	$\Omega$
Motor Supply Current (No Load)	$I_{BB(ON)}$	$D_0 = D_1 = D_2 = V_{IN(1)}$	—	500	700	$\mu\text{A}$
	$I_{BB(OFF)}$	$D_0 = D_1 = D_2 = V_{IN(0)}$	—	250	500	$\mu\text{A}$
<b>Control Circuitry</b>						
Logic Supply Voltage Range	$V_{CC}$	Operating	4.5	5.0	5.5	V
Reference Voltage Range	$V_{REF}$	Operating	0.5	—	2.5	V
UVLO Enable Threshold		$V_{CC} = 0 \rightarrow 5$ V	3.35	3.7	4.05	V
UVLO Hysteresis			0.3	0.45	0.6	V
Logic Supply Current	$I_{CC(ON)}$	$D_0 = D_1 = D_2 = V_{IN(1)}$	—	2.7	—	mA
	$I_{CC(OFF)}$	$D_0 = D_1 = D_2 = V_{IN(0)}$	—	2.7	—	mA
Logic Input Voltage	$V_{IN(1)}$		$V_{CC} \times 0.55$	—	—	V
	$V_{IN(0)}$		—	—	$V_{CC} \times 0.27$	V
Logic Input Current	$I_{IN(1)}$	$V_{IN} = V_{CC} = 5$ V	—	0	-10	$\mu\text{A}$
	$I_{IN(0)}$	$V_{IN} = 0$ V, $V_{CC} = 5$ V	—	-106	-200	$\mu\text{A}$
Mixed-Decay Comparator Trip Points	$V_{PFD}$	Slow Current-Decay Mode	3.5	—	—	V
		Mixed Current-Decay Mode	1.1	—	3.1	V
		Fast Current-Decay Mode	—	—	0.8	V
Mixed-Decay Comparator Input Offset Voltage	$V_{IO(PFD)}$		—	0	$\pm 50$	mV
Mixed-Decay Comparator Hysteresis	$\Delta V_{IO(PFD)}$		5	25	55	mV
Reference Input Current	$I_{REF}$	$V_{REF} = 0.5$ to $2.5$ V	—	—	$\pm 5.0$	$\mu\text{A}$
Reference Divider Ratio	$V_{REF}/V_S$	At trip, $D_0 = D_1 = D_2 = V_{IN(1)}$	—	5	—	—
Digital-to-Analog Converter Accuracy*	—	$1.0$ V < $V_{REF} \leq 2.5$ V	—	—	$\pm 3.0$	%
		$0.5$ V $\leq V_{REF} \leq 1.0$ V	—	—	$\pm 4.0$	%

Continued next page...

## ELECTRICAL CHARACTERISTICS (continued) at $T_A = 25^\circ\text{C}$ , $V_{CC} = 4.5$ to $5.5$ V (unless otherwise noted.)

Characteristic	Symbol	Test Conditions	Min.	Typ.	Max.	Unit
<b>Control Circuitry (cont'd)</b>						
Current-Sense Comparator Input Offset Voltage*	$V_{IO(S)}$	$V_{REF} = 0$ V	—	—	$\pm 5.0$	mV
Step Reference Current Ratio	SRCR	$D_0 = D_1 = D_2 = V_{IN(0)}$	—	0	—	%
		$D_0 = V_{IN(1)}, D_1 = D_2 = V_{IN(0)}$	—	19.5	—	%
		$D_0 = V_{IN(0)}, D_1 = V_{IN(1)}, D_2 = V_{IN(0)}$	—	38.2	—	%
		$D_0 = D_1 = V_{IN(1)}, D_2 = V_{IN(0)}$	—	55.5	—	%
		$D_0 = D_1 = V_{IN(0)}, D_2 = V_{IN(1)}$	—	70.7	—	%
		$D_0 = V_{IN(1)}, D_1 = V_{IN(0)}, D_2 = V_{IN(1)}$	—	83.1	—	%
		$D_0 = V_{IN(0)}, D_1 = D_2 = V_{IN(1)}$	—	92.4	—	%
		$D_0 = D_1 = D_2 = V_{IN(1)}$	—	100	—	%
Thermal Shutdown Temp.	$T_J$		—	165	—	$^\circ\text{C}$
Thermal Shutdown Hysteresis	$\Delta T_J$		—	15	—	$^\circ\text{C}$
<b>AC Timing</b>						
PWM RC Fixed Off-time	$t_{OFFRC}$	$C_T = 470$ pF, $R_T = 43$ k $\Omega$	18.2	20.2	22.3	$\mu\text{s}$
PWM Minimum On Time	$t_{ON(min)}$	$V_{CC} = 5.0$ V, $R_T \geq 43$ k $\Omega$ , $C_T = 470$ pF, $I_{OUT} = 100$ mA	0.8	1.6	2.2	$\mu\text{s}$

\* The total error for the  $V_{REF}/V_S$  function is the sum of the D/A error and the current-sense comparator input offset voltage.

**Table 1 — PHASE Truth Table**

PHASE	OUT <sub>A</sub>	OUT <sub>B</sub>
H	H	L
L	L	H

**Table 2 — PFD Truth Table**

$V_{PFD}$	Description
$\geq 3.5$ V	Slow Current-Decay Mode
1.1 V to 3.1 V	Mixed Current-Decay Mode
$\leq 0.8$ V	Fast Current-Decay Mode

**Table 3 — DAC Truth Table**

DAC DATA			Current Ratio, %	$V_{REF}/V_S$
D <sub>2</sub>	D <sub>1</sub>	D <sub>0</sub>		
H	H	H	100	5.00
H	H	L	92.4	5.41
H	L	H	83.1	6.02
H	L	L	70.7	7.07
L	H	H	55.5	9.01
L	H	L	38.2	13.09
L	L	H	19.5	25.64
L	L	L	All Outputs Disabled	

where  $V_S = I_{TRIP} \times R_S$ . See Applications section.

Note the A4975SB (DIP) and the A4975SLB (SOIC) are electrically identical and share a common terminal number assignment.

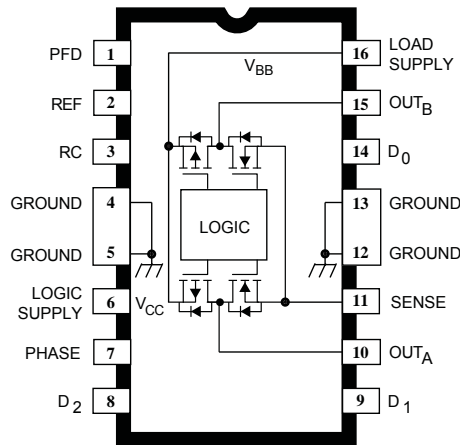

## Terminal Functions

Terminal	Name	Description
1	PFD	(Percent Fast Decay) The analog input used to set the current-decay mode.
2	REF	( $V_{REF}$ ) The voltage at this input (along with the value of $R_S$ and the states of DAC inputs $D_0$ , $D_1$ , and $D_2$ ) set the peak output current.
3	RC	The parallel combination of external resistor $R_T$ and capacitor $C_T$ set the off time for the PWM current regulator. $C_T$ also sets the blanking time.
4-5	GROUND	Return for the logic supply ( $V_{CC}$ ) and load supply ( $V_{BB}$ ); the reference for all voltage measurements.
6	LOGIC SUPPLY	( $V_{CC}$ ) Supply voltage for the logic circuitry. Typically = 5 V.
7	PHASE	The PHASE input determines the direction of current in the load.
8	$D_2$	( $DATA_2$ ) One-of-three (MSB) control bits for the internal digital-to-analog converter.
9	$D_1$	( $DATA_1$ ) One-of-three control bits for the internal digital-to-analog converter.
10	$OUT_A$	One-of-two output load connections.
11	SENSE	Connection to the sink-transistor emitters. Sense resistor $R_S$ is connected between this point and ground.
12-13	GROUND	Return for the logic supply ( $V_{CC}$ ) and load supply ( $V_{BB}$ ); the reference for all voltage measurements.
14	$D_0$	( $DATA_0$ ) One-of-three (LSB) control bits for the internal digital-to-analog converter.
15	$OUT_B$	One-of-two output load connections.
16	LOAD SUPPLY	( $V_{BB}$ ) Supply voltage for the load.

**Functional Description**

Two A4975 full-bridge PWM microstepping motor drivers are needed to drive the windings of a bipolar stepper motor. Internal pulse width modulated (PWM) control circuitry regulates each motor winding current. The peak motor current is set by the value of an external current-sense resistor ( $R_S$ ), a reference voltage ( $V_{REF}$ ), and the digital-to-analog converter (DAC) data inputs ( $D_0$ ,  $D_1$ , and  $D_2$ ).

To improve motor performance, especially when using sinusoidal current profiles necessary for microstepping, the A4975 has three distinct current-decay modes: slow decay, fast decay, and mixed decay.

**PHASE Input.** The PHASE input controls the direction of current flow in the load (table 1). An internally generated dead time of approximately 500 ns prevents crossover currents that could occur when switching the PHASE input.

**DAC Data Inputs ( $D_0$ ,  $D_1$ ,  $D_2$ ).** A non-linear DAC is used to digitally control the output current. The output of the DAC is used to set the trip point of the current-sense comparator. Table 3 shows DAC output voltages for each input condition. When  $D_0$ ,  $D_1$ , and  $D_2$  are all logic low, all of the power output transistors are turned off.

**Internal PWM Current Control.** Each motor driver contains an internal fixed off-time PWM current-control circuit that limits the load current to a desired value ( $I_{TRIP}$ ). Initially, a diagonal pair of source and sink transistors are enabled and current flows through the motor winding and  $R_S$  (figure 1). When the voltage across the sense resistor equals the DAC output voltage the current-sense comparator resets the PWM latch,

which turns off the source drivers (slow-decay mode) or the sink and source drivers (fast- or mixed-decay mode).

With the DAC data input lines at  $V_{IN(1)}$  voltage, the maximum value of current limiting is set by the selection of  $R_S$  and  $V_{REF}$  with a transconductance function approximated by:

$$I_{TRIP} \approx V_{REF} / 5R_S.$$

The actual peak load current ( $I_{PEAK}$ ) will be slightly higher than  $I_{TRIP}$  due to internal logic and switching delays. The driver(s) remain off for a time period determined by a user-selected external resistor-capacitor combination ( $R_T C_T$ ). At the end of the fixed off-time, the driver(s) are re-enabled, allowing the load current to increase to  $I_{TRIP}$  again, maintaining an average load current.

The DAC data input lines are used to provide up to eight levels of output current. The internal 3-bit digital-to-analog converter reduces the reference input to the current-sense comparator in precise steps (the step reference current ratio or SRCR) to provide half-step, quarter-step, or “microstepping” load-current levels.

$$I_{TRIP} \approx SRCR \times V_{REF} / 5R_S$$

**Slow Current-Decay Mode.** When  $V_{PFD} \geq 3.5$  V, the device is in slow current-decay mode (the source drivers are disabled when the load current reaches  $I_{TRIP}$ ). During the fixed off-time, the load inductance causes the current to recirculate through the motor winding and sink drivers (see figure 1). Slow-decay mode produces low ripple current for a given fixed off-time (see figure 2). Low ripple current is desirable because the average current in the motor winding is more nearly equal to the desired reference value, resulting in increased motor

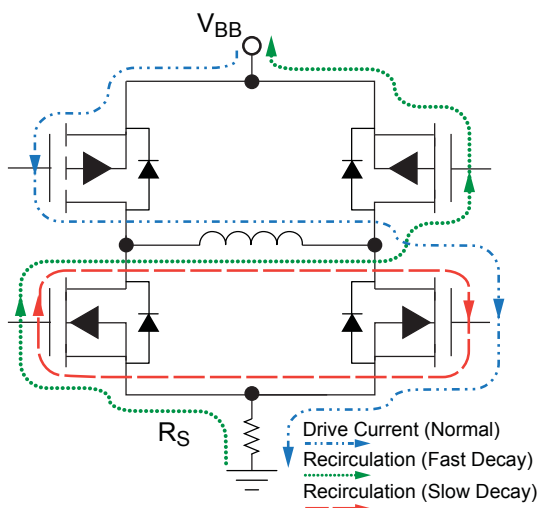
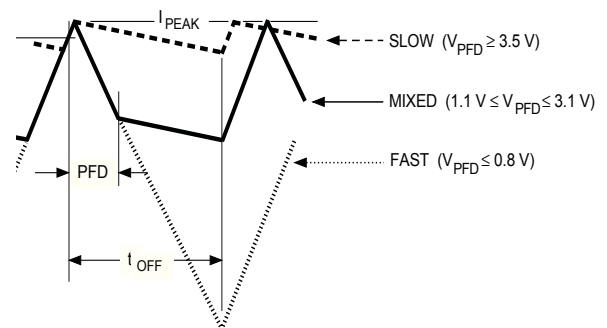

Figure 1 — Load-Current Paths



Dwg. WP-031-1

Figure 2 — Current-Decay Waveforms

performance in microstepping applications.

For a given level of ripple current, slow decay affords the lowest PWM frequency, which reduces heating in the motor and driver IC due to a corresponding decrease in hysteretic core losses and switching losses respectively. Slow decay also has the advantage that the PWM load current regulation can follow a more rapidly increasing reference before the PWM frequency drops into the audible range. For these reasons slow-decay mode is typically used as long as good current regulation can be maintained.

Under some circumstances slow-decay mode PWM can fail to maintain good current regulation:

- 1) The load current will fail to regulate in slow-decay mode due to a sufficiently negative back-EMF voltage in conjunction with the low voltage drop across the load during slow decay recirculation. The negative back-EMF voltage can cause the load current to actually increase during the slow decay off time. A negative back-EMF voltage condition commonly occurs when driving stepping motors because the phase lead of the rotor typically causes the back-EMF voltage to be negative towards the end of each step (see figure 3A).
- 2) When the desired load current is decreased rapidly, the slow rate of load current decay can prevent the current from following the desired reference value.
- 3) When the desired load current is set to a very low value, the current-control loop can fail to regulate due to its minimum duty cycle, which is a function of the user-selected value of  $t_{OFF}$  and the minimum on-time pulse width  $t_{on(min)}$  that occurs each time the PWM latch is reset.

**Fast Current-Decay Mode.** When  $V_{PFD} < 0.8$  V, the device is in fast current-decay mode (both the sink and source drivers are disabled when the load current reaches  $I_{TRIP}$ , and the opposite pair is turned on). During the fixed off-time, the load inductance causes the current to flow from ground to the load supply via the motor winding and the opposite pair of transistors (see figure 1). Because the full motor supply voltage is across the load during fast-decay recirculation, the rate of load current decay is rapid, producing a high ripple current for a given fixed off-time (see figure 2). This rapid rate of decay allows good current regulation to be maintained at the cost of decreased average current accuracy or increased driver and motor losses.

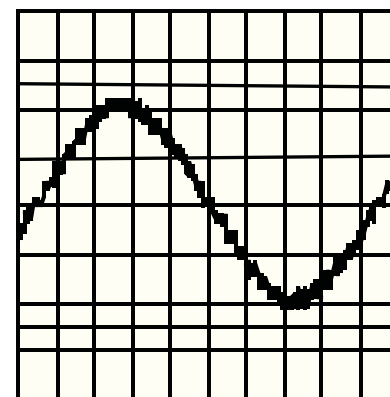
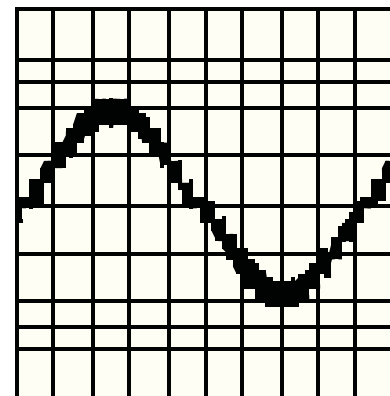

Figure 3 — Sinusoidal Drive Currents

**Mixed Current-Decay Mode.** If  $V_{PFD}$  is between 1.1 V and 3.1 V, the device will be in a mixed current-decay mode. Mixed-decay mode allows the user to achieve good current regulation with a minimum amount of ripple current and motor/driver losses by selecting the minimum percentage of fast decay required for their application (see also the Stepper Motor Applications section).

As in fast current-decay mode, mixed-decay starts with the sink and source drivers disabled and the opposite pair turned on after the load current reaches  $I_{TRIP}$ . When the voltage at the RC terminal decays to a value below  $V_{PFD}$ , the sink drivers are re-enabled, placing the device in slow current-decay mode for the remainder of the fixed off-time (figure 2). The percentage of fast decay (PFD) is user determined by  $V_{PFD}$  or two external resistors.

$$PFD = 100 \ln (0.6[R_1+R_2]/R_2)$$

where:

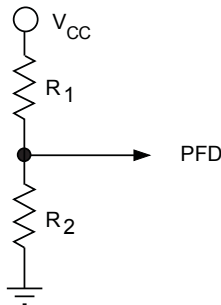

**Fixed Off-Time.** The internal PWM current-control circuitry uses a one shot to control the time the driver(s) remain(s) off. The one-shot off-time,  $t_{OFF}$ , is determined by the selection of an external resistor ( $R_T$ ) and capacitor ( $C_T$ ) connected from the RC timing terminal to ground. The off-time, over a range of values of  $C_T = 470$  pF to 1500 pF and  $R_T = 12$  k $\Omega$  to 100 k $\Omega$ , is approximated by:

$$t_{OFF} \approx R_T C_T$$

When the load current is increasing, but has not yet reached the sense-current comparator threshold ( $I_{TRIP}$ ), the voltage on the RC terminal is approximately  $0.6V_{CC}$ . When  $I_{TRIP}$  is reached, the PWM latch is reset by the current-sense comparator and the voltage on the RC terminal will decay until it reaches approximately  $0.22V_{CC}$ . The PWM latch is then set, thereby re-enabling the driver(s) and allowing load current to increase

again. The PWM cycle repeats, maintaining the peak load current at the desired value.

With increasing values of  $t_{OFF}$ , switching losses will decrease, low-level load-current regulation will improve, EMI will be reduced, the PWM frequency will decrease, and ripple current will increase. A value of  $t_{OFF}$  can be chosen for optimization of these parameters. For applications where audible noise is a concern, typical values of  $t_{OFF}$  are chosen to be in the range of 15 to 35  $\mu$ s.

**RC Blanking.** In addition to determining the fixed off-time of the PWM control circuit, the  $C_T$  component sets the comparator blanking time. This function blanks the output of the current-sense comparator when the outputs are switched by the internal current-control circuitry (or by the PHASE input, or when the device is enabled with the DAC data inputs). The comparator output is blanked to prevent false over-current detections due to reverse recovery currents of the clamp diodes, and/or switching transients related to distributed capacitance in the load.

During internal PWM operation, at the end of the  $t_{OFF}$  time, the comparator's output is blanked and  $C_T$  begins to be charged from approximately  $0.22V_{CC}$  by an internal current source of approximately 1 mA. The comparator output remains blanked until the voltage on  $C_T$  reaches approximately  $0.6V_{CC}$ . The blanking time,  $t_{BLANK}$ , can be calculated as:

$$t_{BLANK} = R_T C_T \ln (R_T / [R_T - 3 \text{ k}\Omega])$$

When a transition of the PHASE input occurs,  $C_T$  is discharged to near ground during the crossover delay time (the crossover delay time is present to prevent simultaneous conduction of the source and sink drivers). After the crossover delay,  $C_T$  is charged by an internal current source of approximately 1 mA. The comparator output remains blanked until the voltage on  $C_T$  reaches approximately  $0.6V_{CC}$ .

Similarly, when the device is disabled, via the DAC data inputs,  $C_T$  is discharged to near ground. When the device is re-enabled,  $C_T$  is charged by an internal current source of approximately 1 mA. The comparator output remains blanked until the voltage on  $C_T$  reaches approximately  $0.6V_{CC}$ . The blanking time,  $t_{BLANK}$ , can be calculated as:

$$t_{BLANK} = R_T C_T \ln ([R_T - 1.1 \text{ k}\Omega] / R_T - 3 \text{ k}\Omega)$$

The minimum recommended value for  $C_T$  is  $470 \text{ pF} \pm 5\%$ . This value ensures that the blanking time is sufficient to avoid

false trips of the comparator under normal operating conditions. For optimal regulation of the load current, this value for  $C_T$  is recommended and the value of  $R_T$  can be sized to determine  $t_{OFF}$ .

**Thermal Considerations.** Thermal-protection circuitry turns off all output transistors when the junction temperature reaches approximately  $+165^{\circ}\text{C}$ . This is intended only to protect the device from failures due to excessive junction temperatures and should not imply that output short circuits are permitted. The output transistors are re-enabled when the junction temperature cools to approximately  $+150^{\circ}\text{C}$ .

**Stepper Motor Applications.** The A4975 is used to optimize performance in microstepping/sinusoidal stepper-motor drive applications (see figures 4 and 5). When the load current is increasing, the slow current-decay mode is used to limit the switching losses in the driver and iron losses in the motor. This also improves the maximum rate at which the load current can increase (as compared to fast decay) due to the slow rate of decay during  $t_{OFF}$ . When the load current is decreasing, the mixed current-decay mode is used to regulate the load current to the desired level. This prevents tailing of the current profile caused by the back-EMF voltage of the stepper motor (see figure 3A).

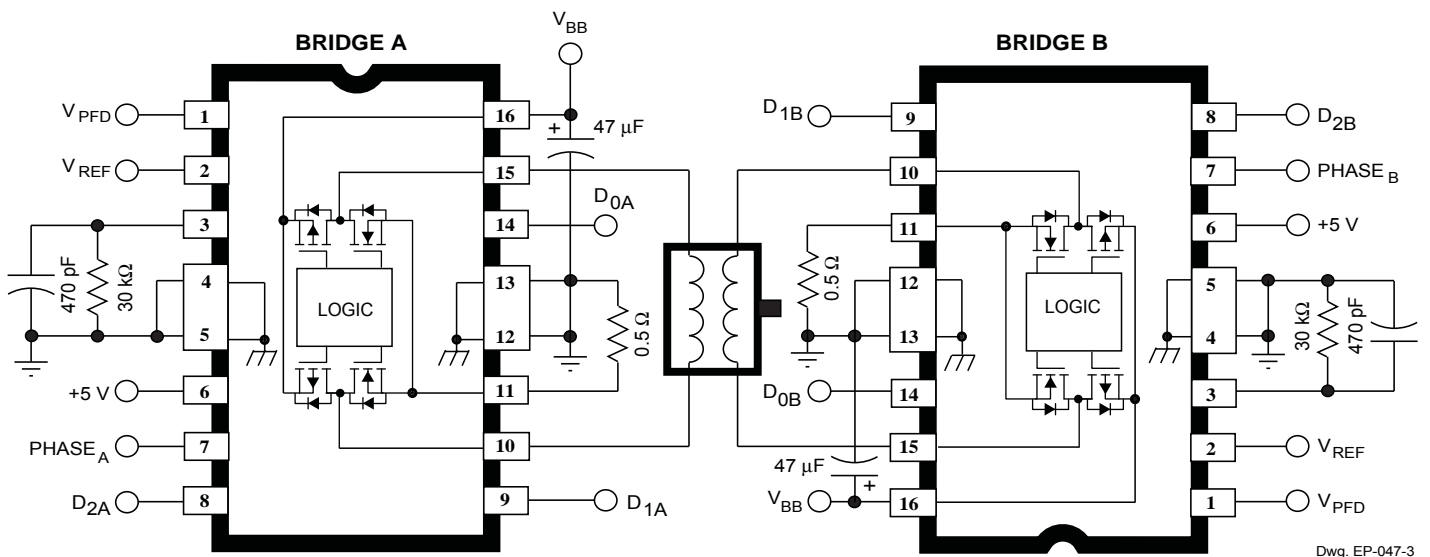

Figure 4 — Typical Application

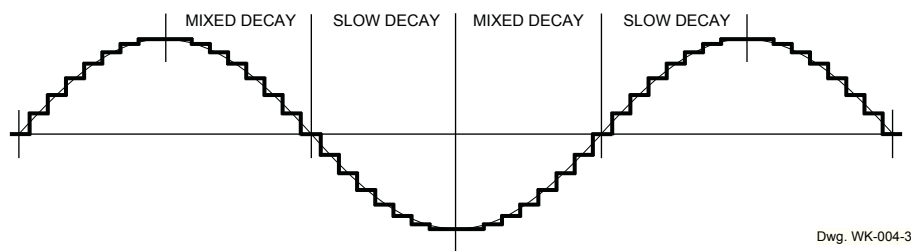

Figure 5 — Microstepping/Sinusoidal Drive Current

**Table 4 — Step Sequencing**

Full Step	Half Step	Quarter Step	Eighth Step	Bridge A					Bridge B				
				PHASE <sub>A</sub>	D <sub>2A</sub>	D <sub>1A</sub>	D <sub>0A</sub>	I <sub>LOADA</sub>	PHASE <sub>B</sub>	D <sub>2B</sub>	D <sub>1B</sub>	D <sub>0B</sub>	I <sub>LOADB</sub>
1	1	1	1	H	H	L	L	70.7%	H	H	L	L	70.7%
			2	H	L	H	H	55.5%	H	H	L	H	83.1%
		2	3	H	L	H	L	38.2%	H	H	H	L	92.4%
			4	H	L	L	H	19.5%	H	H	H	H	100%
	2	3	5	X	L	L	L	0%	H	H	H	H	100%
			6	L	L	L	H	-19.5%	H	H	H	H	100%
		4	7	L	L	H	L	-38.2%	H	H	H	L	92.4%
			8	L	L	H	H	-55.5%	H	H	L	H	83.1%
2	3	5	9	L	H	L	L	-70.7%	H	H	L	L	70.7%
			10	L	H	L	H	-83.1%	H	L	H	H	55.5%
		6	11	L	H	H	L	-92.4%	H	L	H	L	38.2%
			12	L	H	H	H	-100%	H	L	L	H	19.5%
	4	7	13	L	H	H	H	-100%	X	L	L	L	0%
			14	L	H	H	H	-100%	L	L	L	H	-19.5%
		8	15	L	H	H	L	-92.4%	L	L	H	L	-38.2%
			16	L	H	L	H	-83.1%	L	L	H	H	-55.5%
3	5	9	17	L	H	L	L	-70.7%	L	H	L	L	-70.7%
			18	L	L	H	H	-55.5%	L	H	L	H	-83.1%
		10	19	L	L	H	L	-38.2%	L	H	H	L	-92.4%
			20	L	L	L	H	-19.5%	L	H	H	H	-100%
	6	11	21	X	L	L	L	0%	L	H	H	H	-100%
			22	H	L	L	H	19.5%	L	H	H	H	-100%
		12	23	H	L	H	L	38.2%	L	H	H	L	-92.4%
			24	H	L	H	H	55.5%	L	H	L	H	-83.1%
4	7	13	25	H	H	L	L	70.7%	L	H	L	L	-70.7%
			26	H	H	L	H	83.1%	L	L	H	H	-55.5%
		14	27	H	H	H	L	92.4%	L	L	H	L	-38.2%
			28	H	H	H	H	100%	L	L	L	H	-19.5%
	8	15	29	H	H	H	H	100%	X	L	L	L	0%
			30	H	H	H	H	100%	H	L	L	H	19.5%
		16	31	H	H	H	L	92.4%	H	L	H	L	38.2%
			32	H	H	L	H	83.1%	H	L	H	H	55.5%

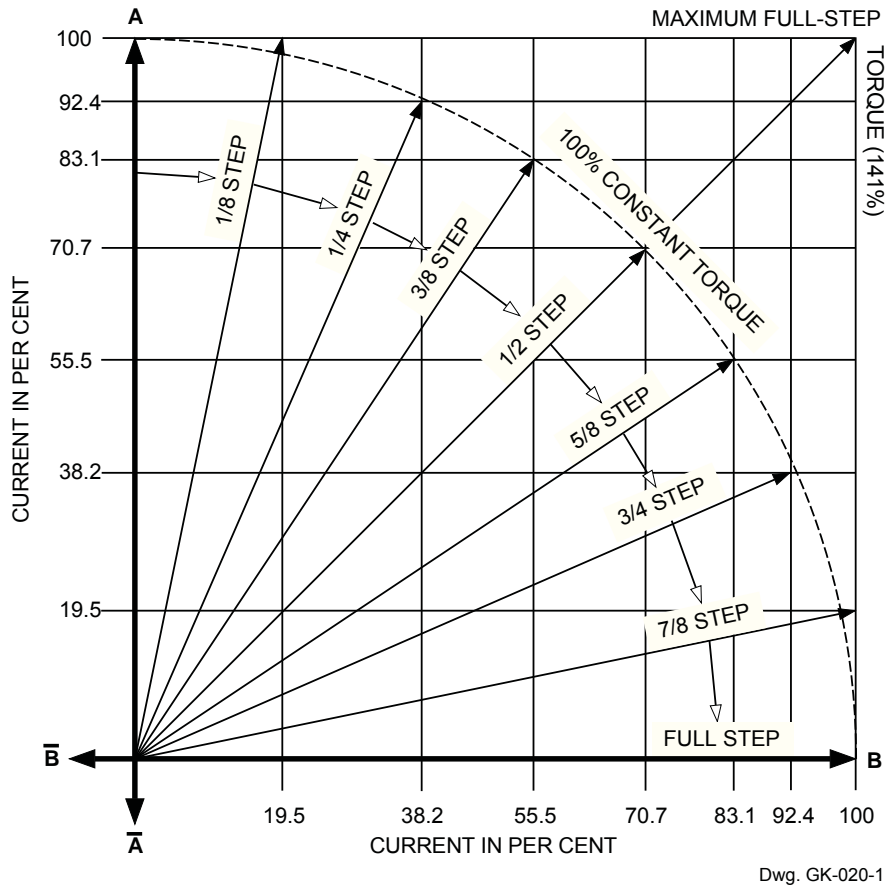
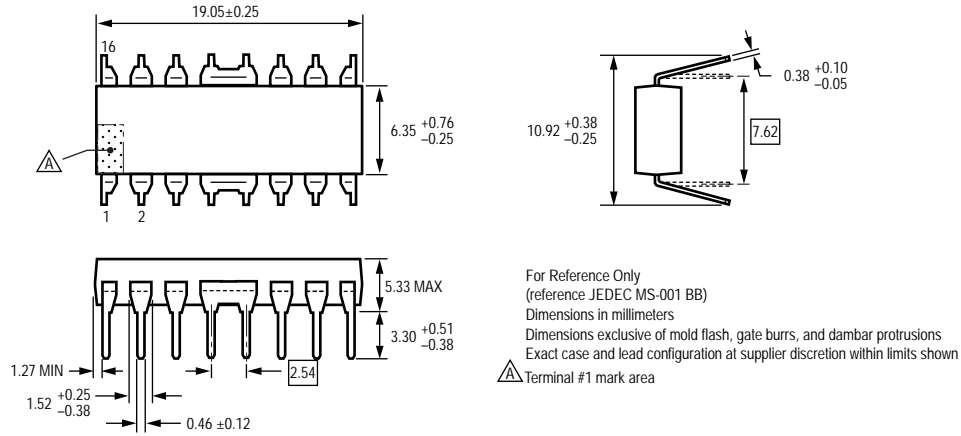
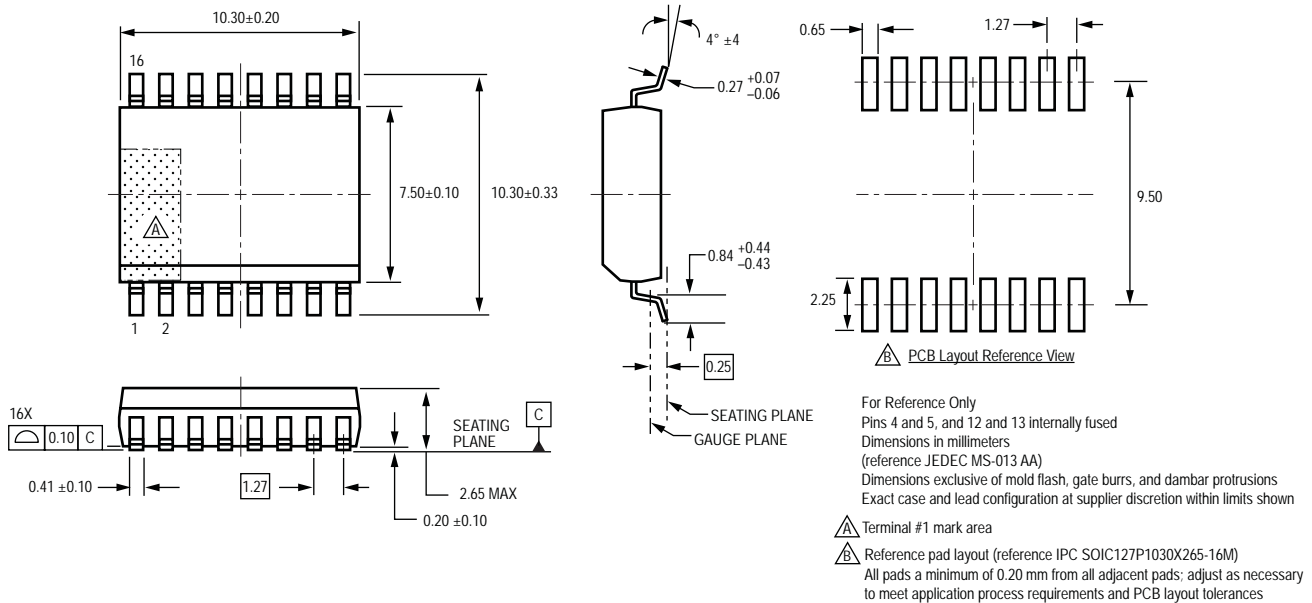

Figure 5 —  
Current and Displacement Vectors

B package 16-pin DIP



LB package 16-pin SOICW



**Revision History**

Revision	Revision Date	Description of Revision
Preliminary	October 11, 2011	R <sub>DS</sub> , t <sub>ON(min)</sub> , I <sub>BB(on)</sub> update

Copyright ©2009-2011, Allegro MicroSystems, Inc.

Allegro MicroSystems, Inc. reserves the right to make, from time to time, such departures from the detail specifications as may be required to permit improvements in the performance, reliability, or manufacturability of its products. Before placing an order, the user is cautioned to verify that the information being relied upon is current.

Allegro's products are not to be used in life support devices or systems, if a failure of an Allegro product can reasonably be expected to cause the failure of that life support device or system, or to affect the safety or effectiveness of that device or system.

The information included herein is believed to be accurate and reliable. However, Allegro MicroSystems, Inc. assumes no responsibility for its use; nor for any infringement of patents or other rights of third parties which may result from its use.

For the latest version of this document, visit our website:

[www.allegromicro.com](http://www.allegromicro.com)