

SPECIFICATIONS	
CONTACT CARRIER MATERIAL	TPU
MOLDED HEAD MATERIAL/COLOR	TPU/YELLOW
CONTACT MATERIAL/PLATING	BRASS/GOLD
COUPLING NUT MATERIAL/FINISH	STAINLESS STEEL/PASSIVATED
RATED CURRENT [A]	9.0 A
RATED VOLTAGE [V]	600 V
OUTER JACKET MATERIAL/COLOR	TPU/YELLOW
NUMBER OF CONDUCTORS [AWG]	4x18 AWG
CONDUCTOR INSULATION MATERIAL	PVC
TEMPERATURE RATING	-40°C to +90°C (-40°F to +194°F)
PROTECTION CLASS	MEETS NEMA 1,3,4,6P AND IEC IP67

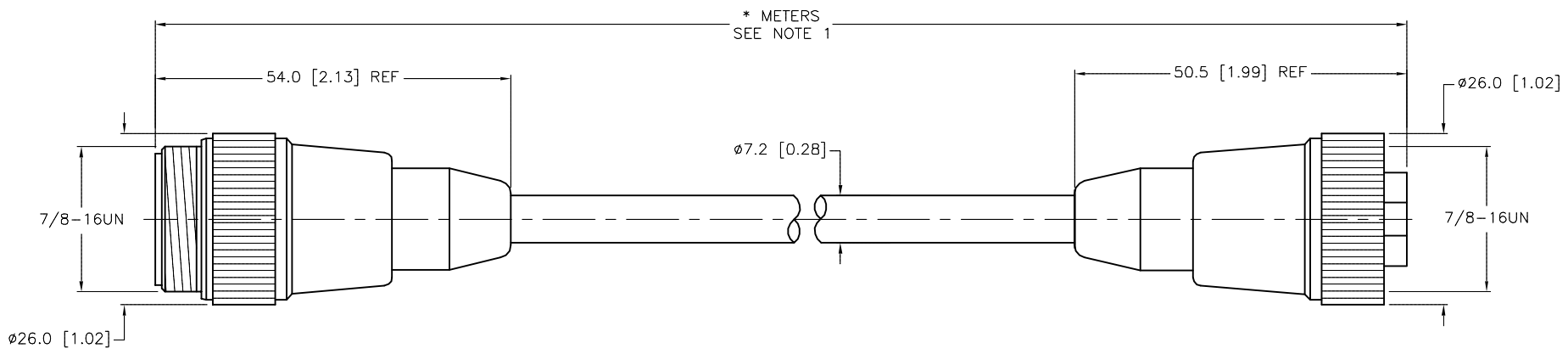

CABLE LENGTH	TOLERANCE*
ALL LENGTHS	+ 4% (OR 50mm) OF LENGTH - 0% (OR 0mm) OF LENGTH WHICHEVER IS GREATER
STRIP LENGTH	TOLERANCE*
0-7mm	±0.5mm
8-29mm	±1.0mm
30-49mm	±2.0mm
50-69mm	±3.0mm
70-100mm	±4.0mm
OVER 100mm	±5.0mm

\* UNLESS OTHERWISE SPECIFIED

NOTES:  
 1. "\*" INDICATES CABLE LENGTH IN METERS. CONTACT TURCK TO ORDER SPECIFIC LENGTHS.  
 2. "/S90" DESIGNATES THERMOPLASTIC POLYURETHANE (TPU) CABLE.

SOURCE DRAWING - FOR REFERENCE ONLY

RELATED DOCUMENTS 1. 2. 3. 4.	3RD ANGLE PROJECTION 	THIS DRAWING IS CONFIDENTIAL AND THE PROPERTY OF TURCK INC. USE OF THIS DOCUMENT WITHOUT WRITTEN PERMISSION IS PROHIBITED.		<b>TURCK INC</b> High Technology Sensors and Automation Controls 3000 CAMPUS DRIVE MINNEAPOLIS, MN 55441 1-800-544-7769 (763) 553-7300 (763) 553-0708 fax turck.com	
		DRFT RDS	DATE 02/19/09	DESCRIPTION RSV RKV 40-*M/S90	
MATERIAL SEE SPECIFICATIONS	ALL DIMENSIONS DISPLAYED ON THIS DRAWING ARE FOR REFERENCE ONLY	APVD	SCALE 1=1.0	IDENTIFICATION NO.	
FINISH SEE SPECIFICATIONS		UNIT OF MEASUREMENT <b>MILLIMETER [ INCH ]</b>		REV D	
DO NOT SCALE THIS DRAWING		FILE: 777008725		SHEET 1 OF 1	

D	UPDATE VOLTAGE RATING	RDS	06/07/12	39016
REV	DESCRIPTION	BY	DATE	ECO NO.