

Pezzi di Ricambio

Spare parts

Pièces de rechange

Piezas de recambios

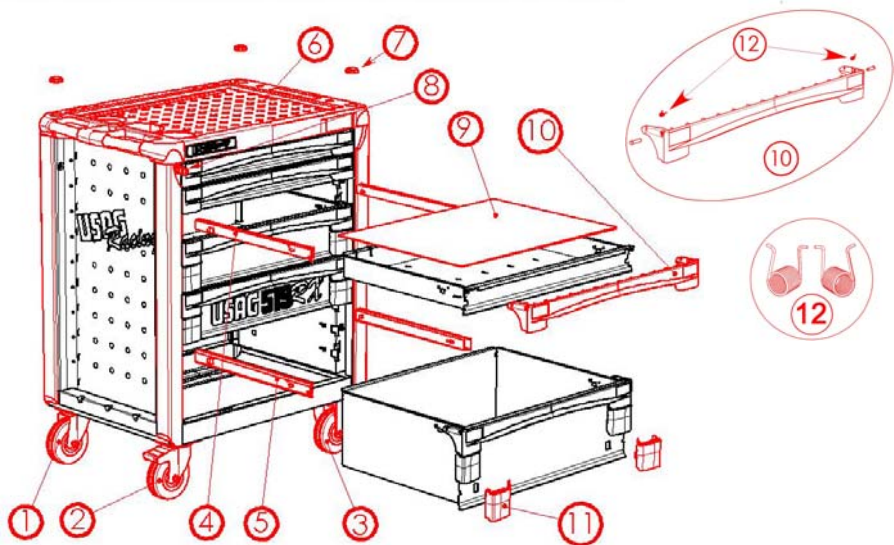

519RX

Istruzioni per l'utilizzo

Notice d'instructions

Instruction manual

Guia de instrucciones







519 RX5V
519 RX5GV

519 RX6V
519 RX6GV

519 RX7V
519 RX7GV

519 RX8V
519 RX8GV



Rèp	Codice	519 RX5V 519 RX5GV	519 RX6V 519 RX6GV	519 RX7V 519 RX7GV	519 RX8V 519 RX8GV
1	Q519092	1	1	1	1
2	Q519093	1	1	1	1
3	Q519091	2	2	2	2
4	Q519482 	2	3	5	6
5	Q519483 	3	3	2	2
6	Q519485	1	1	1	1
7	Q519486 x3	1	1	1	1
8	Q519070	1	1	1	1
9	Q519487	5	6	7	8
10	Q519488	5	6	7	8
11	Q519489 	5	4	3	2
12	Q519490 	5	6	7	8

Cod. Y080260050/0



Utensilerie Associate S.p.A - Via Volta, 3 - 21020 Monvalle (VA) Italia
 Tel. 0332/790111 - Telefax 0332/790602 - E.mail : info.mv@usag.it

Carrello per Officina
 Servante d'atelier
 Roller Cabinet
 Carro de Taller



Funzionamento
Fonctionnement

Operation
Funcionamento

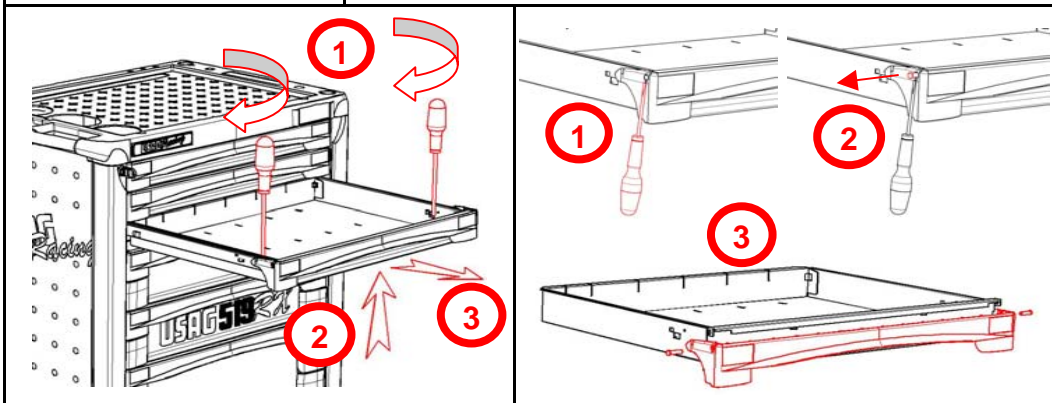
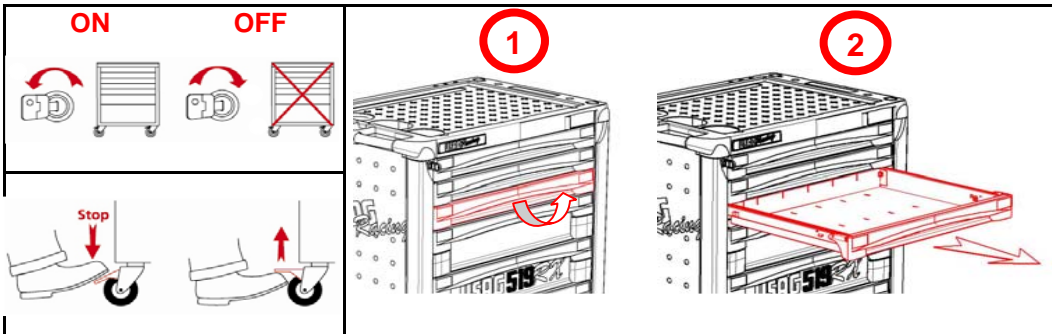

Caratteristiche
Caractéristiques

Specifications
Características

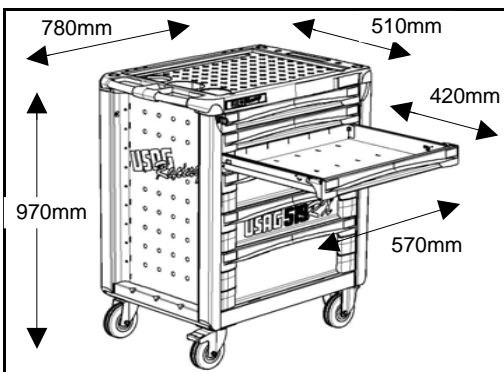

519 RX5V
519 RX5GV

519 RX6V
519 RX6GV

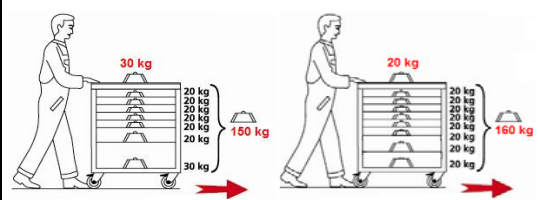

519 RX7V
519 RX7GV

519 RX8V
519 RX8GV

519 RX5V - 519 RX5GV 67 kg

519 RX6V - 519 RX6GV 69 kg

519 RX7V - 519 RX7GV 71 kg

519 RX8V - 519 RX8GV 73 kg

900 kg

Manutenzione
Entretien

Maintenance
Mantenimiento



Accessori
Accessoires

Proprietes
Accesorios

