

- threaded barrel, M12 x 1
- Chrome-plated brass
- factor 1 for all metals
- degree of protection IP68
- magnetic field immune
- high switching distance
- integrated predamping protection
- small metal-free zones
- 3-wire DC, 10...30 VDC
- normally closed, pnp output
- male connector, M12 x 1

Wiring diagram

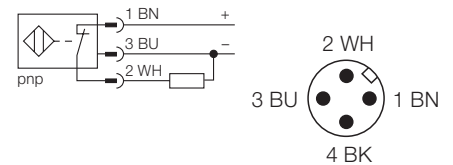

Functional principle

Inductive sensors are designed for wear-free and non-contact detection of metal objects. uprox+ sensors have considerable advantages due to their patented multi-coil system. They excel in highest switching distances, maximum flexibility and operational reliability as well as efficient standardisation.

Type	Ni10U-M12-RP6X-H1141
Ident-No.	1634848
Rated operating distance Sn	10 mm
Mounting condition	non-flush
Assured sensing range	≤ (0,81 x Sn) mm
Repeatability	≤ 2 %
Temperature drift	≤ ± 10 %
Hysteresis	≤ ± 15 %, ≤ -25 °C v ≥ +70 °C
Ambient temperature	-30... + 85 °C
Operating voltage	10... 30VDC
Residual ripple	≤ 10 % U _{ss}
DC rated operational current	≤ 200 mA
No-load current I ₀	≤ 15 mA
Residual current	≤ 0.1 mA
Rated insulation voltage	≤ 0.5 kV
Short-circuit protection	yes / cyclic
Voltage drop at I _e	≤ 1.8V
Wire breakage / Reverse polarity protection	yes / complete
Output function	3-wire, normally closed, pnp
Insulation class	□
Switching frequency	≤ 1 kHz
Housing	threaded barrel, M12 x 1
Dimensions	52 mm
Housing material	metal, CuZn, chrome-plated
Material active face	plastic, LCP-GF30
Tightening torque of housing nut	10 Nm
Connection	connectors, M12 x 1
Vibration resistance	55 Hz (1 mm)
Shock resistance	30g (11 ms)
Degree of protection	IP68
Display switch state	LED yellow

Mounting instructions	minimum distances
Distance D	48 mm
Distance W	30 mm
Distance T	36 mm
Distance S	18 mm
Distance G	60 mm
Distance N	16 mm

Diameter of the active area B Ø 12 mm

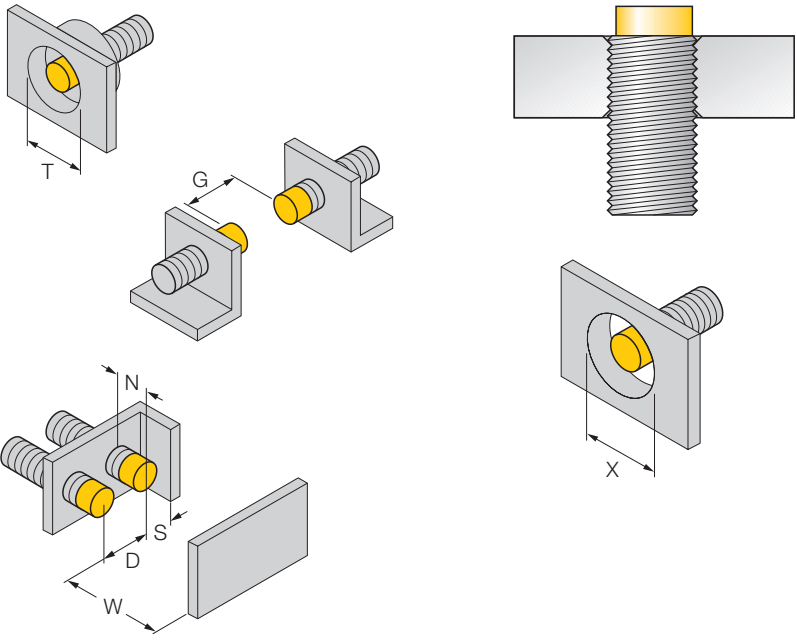

All non-flush mountable uprox+ threaded barrel switches allow embedded mounting up to the upper edge of the thread. Thus safe operation with a maximum reduction of the switching distance of 20 % is guaranteed.

When installing in an aperture plate a clearance of X = 50 mm must be observed.

Accessories

Type code	Ident-No.	Short text	Dimension drawing
QM-12	6945101	quick-mount fixing clamp with dead-stop; material: chrome-plated brass male thread M16 x 1. Note: The switching distance of proximity switches can be reduced by the use of quick mounting brackets.	
BST-12B	6947212	fixing clamp with dead-stop; material: PA6	
MW-12	6945003	mounting bracket; material: stainless steel A2 1.4301 (AISI 304)	
BSS-12	6901321	fixing clamp; material: polypropylene	